

Waltron **AQUALERT**[®] DIVISION

Water Chemistry Measurement & Control



μAI-9044 **Hydrazine Analyzer** **Instruction Manual**

Manual Version 2.15



μAI-9044

WALTRON CUSTOMER COMMITMENT

This instruction manual is a technical guide to aid the customer in the set-up and maintenance of their new Waltron measuring system. Waltron provides continuous product improvement and reserves the right to make any modifications to the information contained herein without notice.

*Copyright © Waltron, 2002
All Rights Reserved*

Technical questions concerning this product should be addressed to:

Waltron Technical Service Department

Whitehouse, New Jersey

Phone: (800)-242-7353 **Fax:** (908)-534-5546

www.waltron.net

Please be ready to provide the following information:

- Date analyzer was purchased.
- Analyzer model and serial number.
- Recent maintenance history.
- Calibration slope values and detailed description of problem.

Waltron's technical expertise and extensive experience provides personalized solutions to the water quality industry. It is Waltron's commitment to provide the customer with timely and accurate technical service and support.

Waltron fully expects the customer to be satisfied with the quality, performance, and cost of this product. If there are any questions or concerns regarding this product, please feel free to contact Waltron at 1-(800)-242-7353.

Thank you for choosing Waltron!

Please note Waltron mailing and UPS shipping addresses:

DIRECT ALL CORRESPONDENCE TO:

Waltron LLC
P.O. Box 70, 50 Tannery Rd.
Whitehouse, NJ 08888

DIRECT ALL UPS SHIPMENTS TO:

Waltron LLC
50 Tannery Rd.
Somerville, NJ 08876



Safety:

Please observe proper safety and handling precautions when installing, operating, maintaining, and servicing this product. The following should be noted and adhered to:

- √ Read and understand manual before working with analyzer.
- √ Pay special attention to warning labels on enclosures, containers, packages and chemicals.
- √ Only qualified personnel should be involved in the installation, operation, and servicing of the analyzer.
- √ Follow safety precautions when operating analyzer in conditions of high pressure and/or temperature.
- √ Keep analyzer chemicals away from heat and extreme temperatures. Reagent powders must be kept dry.
- √ Follow all regulations and warning labels when disposing of chemicals. Do not mix chemicals.

*To obtain analyzer safety information or **Material Safety Data Sheets (MSDS)**, please contact Waltron or logon to www.waltron.net.*



Warranty Agreement

If, within one year from the date of shipment, the customer experiences any equipment defects or is not satisfied with the analyzer manufacturing, Waltron will repair, or at its option, replace any defective part(s) free of charge. This warranty requires that the defective part(s) be returned to Waltron in Whitehouse, NJ with shipping charges prepaid.

At Waltron discretion, a Technical Service Specialist may be sent out to repair or replace the defective part(s) on location. Traveling time and expenses of the Technical Service Specialist is at the customer's expense.

Equipment sent to Waltron must be appropriately packaged and the following information must be provided prior to returning to Waltron:

- √ The Return Authorization (RA) number assigned to the customer by the Waltron Technical Service Department.
- √ Customer name, address and department.
- √ Name and telephone number of the individual responsible for returning items for repair.
- √ Brief problem description.

Ship to Waltron Service Center:

-Via Mail:

Waltron LLC
P.O. Box 70, 50 Tannery Rd.
Whitehouse, NJ 08888

-Via UPS/FED-EX/Motor Carrier:

Waltron LLC
50 Tannery Rd.
Somerville, NJ 08876



Warranty Agreement

Waltron Warranty Agreement:

- √ Covers expendable sensors for one month after shipment and reusable electrodes for six months after shipment.
- √ Does not apply to damages occurred during shipping.
- √ Warranty will be nullified if goods have been used for purposes other than those for which they are intended or if any seal has been removed, broken or tampered with or if the Waltron trademark or serial number has been removed, defaced, or altered.
- √ Does not cover expendable supply items such as reagents, tubing and electrolytes.
- √ Does not cover misuse or mistreatment by the user.
- √ Does not cover previous repair or alteration by unauthorized individuals.

Waltron does not assume responsibility for contingent liability through alleged failure or failures of products or product accessories.



CHECK LIST OF MATERIALS

In order to ensure customer satisfaction, Waltron does its best to provide adequate and timely packaging and shipping services. Please perform the following after receiving a shipment:

- √ Inspect all shipping containers upon receipt and record any visible damage. If there are any outward signs of damage, please retain all containers and packages for inspection by carrier. Please retain all packing material so that it can be used for future moving and shipping needs.

- √ Check all items received against those on the packing list. Chemicals are usually shipped in a separate package and will be itemized accordingly.

- √ Verify that the number of packages received agrees with the packing list and shipping papers.

- √ Notify both Waltron and the carrier if any problems occur.

Important Notice

- √ All monitors are inspected and tested prior to shipment.
- √ In normal use, the unit should require only minor maintenance and should operate correctly and without fault over a long period of time.
- √ Please note that if electronic components need to be replaced, it may be necessary to adjust and/or calibrate the monitor.
- √ Failure to carry out correct maintenance procedures may result in inaccurate monitor reading.



Table of Contents

Section		Contents	Page
1		Introduction	9
	1.1	General Description/ Principle of Operation	9
	1.2	Training	9
	1.3	Physical Overview	9
	1.4	Housing Characteristics	9
2		Installation	10-19
	2.1	Physical Dimensions and Wiring	10-11
	2.2	Location	12
	2.3	Components and Accessories	12
	2.4	Mounting	12
	2.5	Sample Requirements	12
	2.6	Sample Connections	13
	2.7	Standard Bottle Connections	14
	2.8	Reagent Bottle Connections	14
	2.9	Electrical Layout	16
	2.10	User Junction Box	16
	2.11	Microprocessor	16
	2.12	Electrical Connections	17-19
3		Liquid Handling	20-22
	3.1	Principle of Operation	20
	3.2	General Operation	20-22
4		Display Operation	23-24
	4.1	Display Panel Controls	23
	4.2	Status Indication	24
5		Programming	25-45
	5.1	Programming Flowchart	25-27
	5.2	Main Display Page	28
	5.3	Operating Page 1: Start Analysis	29
	5.4	Operating Page 2: Start Monitor	30
	5.5	Operating Page 2: Start Monitor Set-up	31



Table of Contents

Section		Contents	Page	
5	5.6	Operating Page 3: Calibration Page	32	
	5.7	Operating Page 4: Reagents Blank	33	
	5.8	Operating Page 5: Wash	34	
	5.9	Operating Page 6: Dilution	35	
	5.10	Operating Page 7: Prime	36	
	5.10	Operating Pages 8-10: Customization	36	
	5.11	Operating Page 11: Grab Sample	37	
	5.12	Operating Page 12: Solenoid Test	38	
	5.13	Operating Page 13: Reagent Replacement	39	
	5.14	Results Pages	40	
	5.15	Parameters Pages: Basic Set-up	41	
	5.16	Parameters Pages: Calibration Parameters	42	
	5.17	Parameters Pages: Parameter Setting	43	
	5.18	Parameters Pages: Heater Setting & Other Parameters	44	
	5.19	General Settings	45	
	6		Startup	46-47
		6.1	Pre-Commissioning Checklist	46
		6.2	Commissioning Checklist	46
		6.3	Reagent Blank	46
	6.4	Calibration	46	
	6.5	Dilution Factor Calculation	47	
	6.6	Normal Analyzer Operation	47	
7		Maintenance	48-52	
	7.1	Servicing Analyzer	48	
	7.2	Regular Visual Checks	48	
	7.3	Monthly	48	
	7.4	Quarterly	48	
	7.5	Bi-Yearly	48	
	7.6	Consumables Kit	48	
	7.7	Shut-Down Procedure	48	
	7.8	Changing Pump Tube	49-50	
	7.9	Unscheduled Servicing-- <i>Troubleshooting</i>	50-54	
8		Specifications	55	
9		Spare Part Listing	56	
10		Appendix –Panel Mount Schematics	57-59	

1 Introduction-General Overview

1.1 General Description

The μAI-9044 Hydrazine Analyzer is a microprocessor based colorimetric analyzer. The analyzer is capable of measuring hydrazine levels in demineralization and steam generation plants. The instrument is available in single stream or multi-stream configurations.

The μAI-9044 Hydrazine Analyzer is based on Loop Flow Analysis (LFA), an exclusive and patented technology that has allowed Waltron to make new advances in analytical automation. This exclusive technology and compact design allows for low power usage and reagent consumption. The analyzer is able to precisely measure a wide range of values without compromising accuracy.

1.2 Training

Due to the specialized functions of the Waltron 9044 Hydrazine Analyzer, it is recommended that equipment operators be trained prior to the start-up and installation of the analyzer.

1.3 Physical Overview

To measure the amount of hydrazine in a sample, color reagent is added to the sample to form a chemical complex. This complex is then detected and measured by a colorimeter. These steps take place in the Analytical Compartment.

The Electronic Compartment is situated above the Analytical Compartment and houses a microprocessor unit that controls all instrument functions.

The Electronic and Analytical Compartments are easily opened and closed and should be locked to prevent wear on internal components.

The door attached to the hydraulic panel may be opened to gain access to the optical system, solenoid valves and pump motor.

1.4 Housing Characteristics

The μAI-9044 housing meets IP55 protection requirements. All parts coming into contact with the sample and reagents are chemically inert. The external shape and dimensions provide easy installation in industrial plant or interior monitoring stations. See Technical Specifications section for more information.



2 Installation

2.1 Physical dimensions and space requirements

The schematics below show the physical dimensions of the μAI 9044. The total weight of the analyzer, including reagents, is approximately 50 lbs.

Figure 2.1: Unit Dimensions

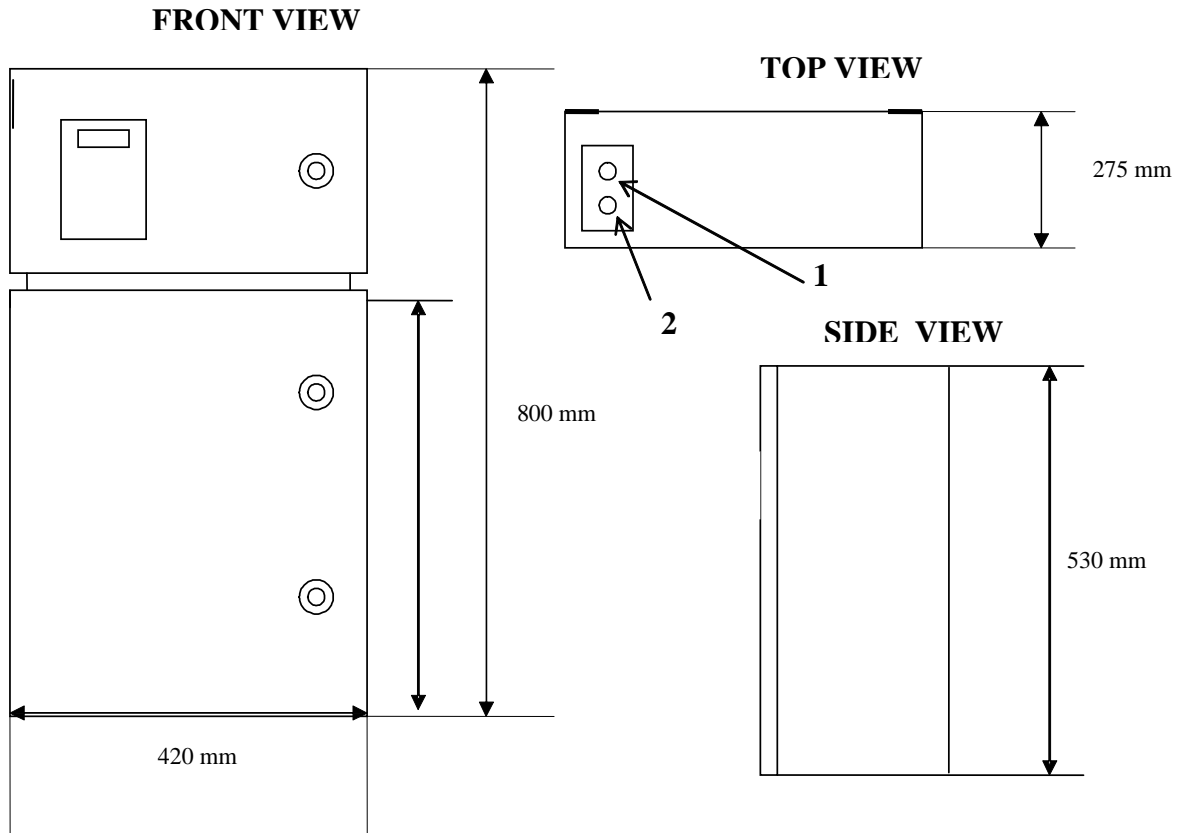

Power Cable Feedhole	1
Signals Wire Feedhole	2
Sample Inlet Connection	3
Sample Overflow Connection	4
Waste Connection	5
Overflow Drain	6

Installation

2.1 Physical dimensions and space requirements

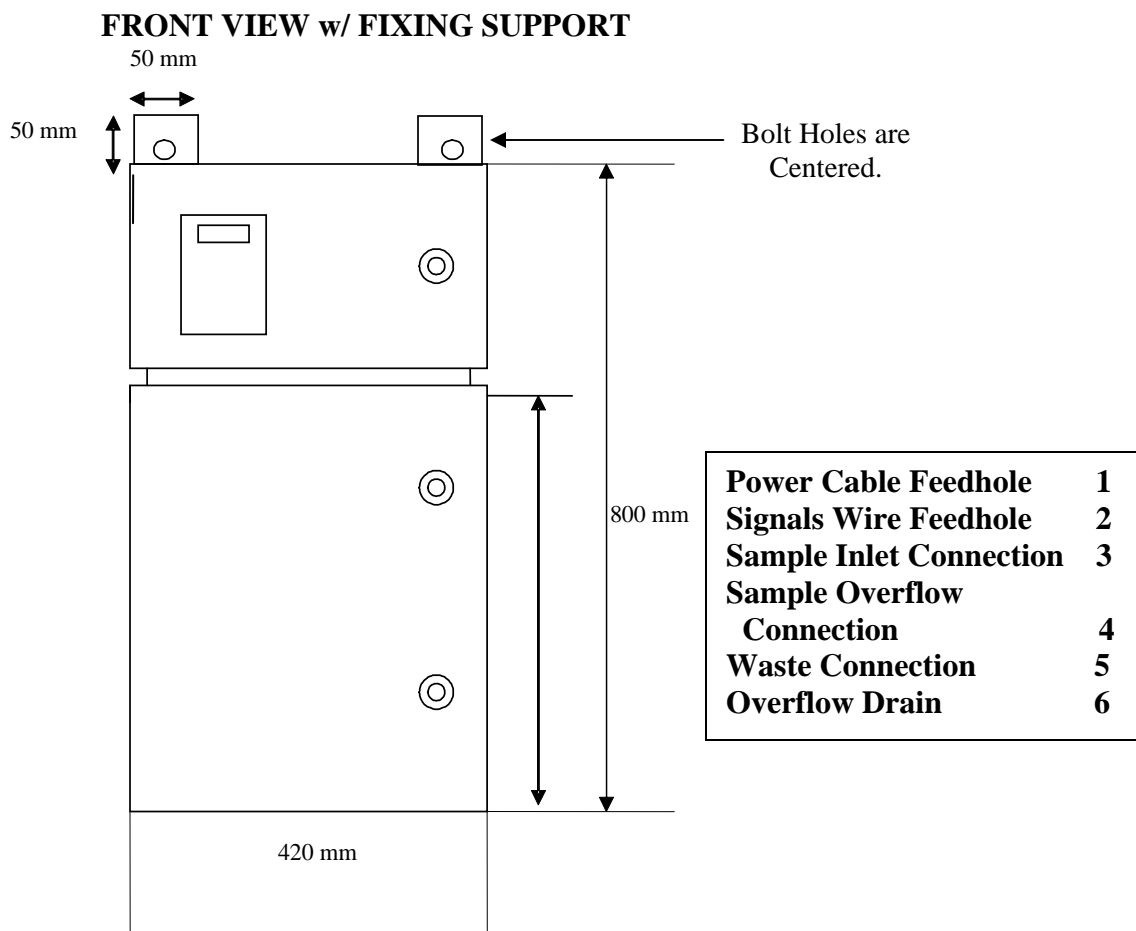
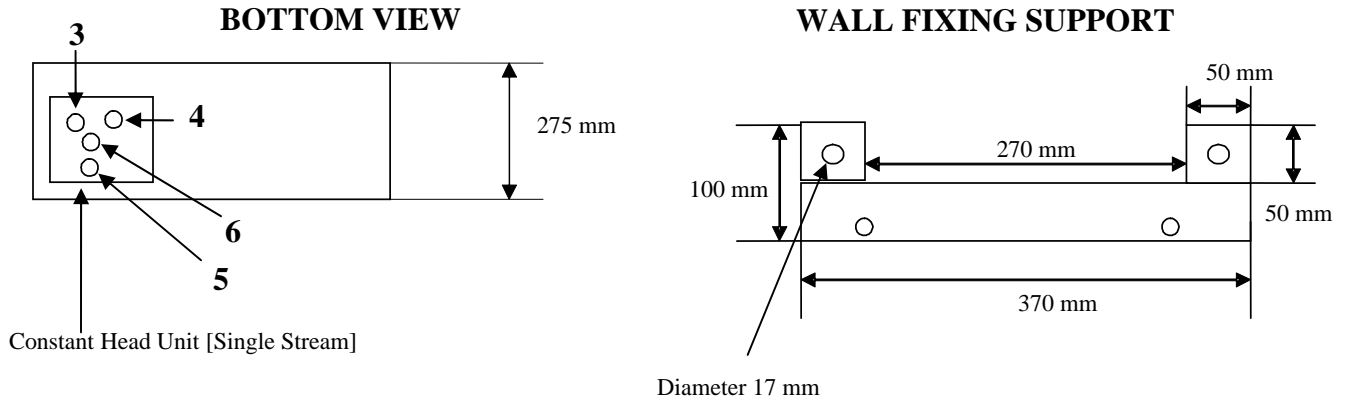

2 Installation

2.2 Location

Proper analyzer location is an important factor in ensuring accuracy, reliability, and minimizing maintenance. Take careful note of the following to obtain peak analyzer performance.

- √ Mount the analyzer in clean, dry, well-ventilated and vibration-free location. Make sure the analyzer is easily accessible. Avoid installing in rooms containing corrosive gases or vapors, e.g. chlorination equipment or chlorine gas cylinders. Use adjacent drains located at ground level to minimize waste line length and utilize maximum fall.
- √ The monitor and power supplies should rest in close proximity to the sample point in order to minimize response delays.
- √ Maintain an ambient room temperature of 5-40°C.
- √ The analyzer requires a supply of deionized water. A 1 liter DI bottle is supplied and should only need to be refilled monthly under normal operation, which includes use for dilution cycles when high level sample is detected, washes, and the flushing out of residuals after calibrations, primes, and reagent blanks.

2.3 Components and Accessories

Analyzer accessories include:

- √ 1 Reagents container.
- √ Calibration standard container.
- √ DI water container. (NOTE: For analyzers using auto dilution a continuous supply of DI may be necessary.)
- √ Consumables kit. (Includes 12-micro filters used for monthly replacement and replacement tubing for the entire analyzer.)

2.4 Mounting—Wall-Mount and Panel-Mount

See *Figure 2.1* for wall-mount procedure and physical dimensions. See *APPENDIX* for panel mount schematics.

2.5 Sample Requirements

The sample stream should be located as close to the monitor as possible. The sample point must also provide a thoroughly mixed representative sample. The sample must conform to the following conditions:

- √ Sample flow rate must be between 150 - 200 ml/min.
- √ Sample temperature should be 5-55°C (41-131 F).
- √ Sample particle concentration must be less than 10 mg/l. Particle size must not exceed 60 microns. If particle size does exceed 60 microns, a filter must be fitted prior to the sample inlet.

2 Installation

2.6 Sample Connections

Connect appropriately sized inlet and overflow tubes to valves shown in *Figure 2.2*. Take note that one outlet is pure sample overflow and that the waste outlet tube connected to the fitting adjacent to the constant head is contaminated waste.

Figure 2.2 - Constant Head Assembly.

Note: Single Stream Analyzers Have only one Constant Head Block

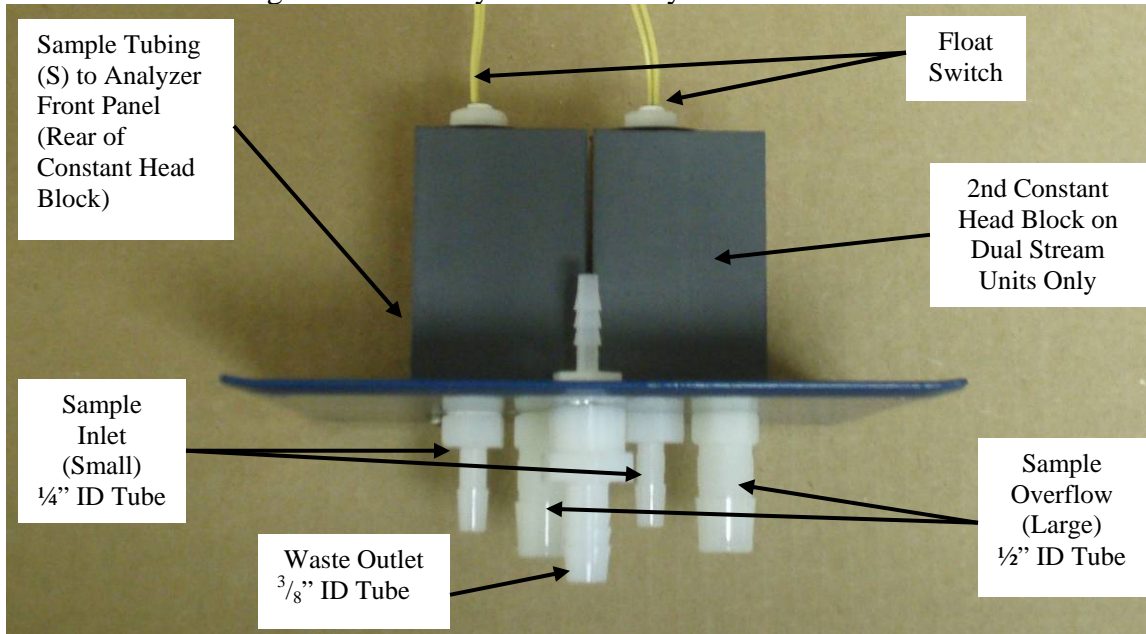
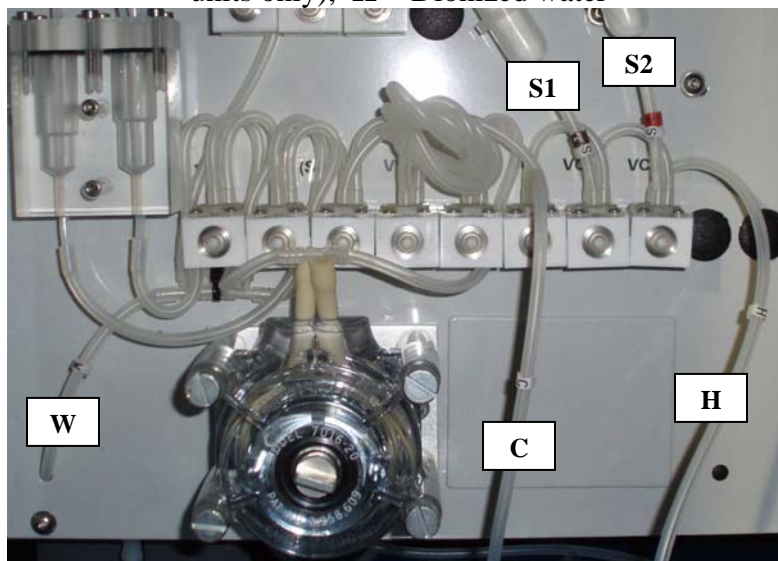

Figure 2.3 - Hydraulic Panel Connection Lines.

W = Waste Tube, C = Calibration Standard, S1 = Sample 1, S2 = Sample 2 (used for multi-stream units only), H = Dionized water



2 Installation

2.7 Standard Bottle Connections

- √ Clean standard and deionized water bottles with DI water and dry before use.
- √ Using the labels on the tubing, insert each tube and straw into their respective containers. Make sure that the straw reaches the bottom of the container.
- √ Insert the straw from tubing C into the hydrazine calibrant standard bottle.
 - ❖ Uses approximately 50 ml for every calibration cycle (20 tests per 1 liter)
- √ Insert the straw from tubing H into DI water
 - ❖ Used for initial start-up, wash, and dilution.



Warning:

- ❖ Reagents must be handled with great care at all times. Appropriate safety equipment such as rubber gloves, full face protection, and lab coat should be worn while working with reagents.
- ❖ Work under a hood and wear rubber gloves and eye protection when working with hazardous chemicals. Sodium Hydroxide 10% is used as cleaning solution.

2.8 Reagent Bottle Connections

- √ Clean reagent bottles with DI water and dry before filling with reagents.
 - √ Using the labels on the tubing, insert each tube and straw into their respective reagent containers. Make sure that the straw reaches the bottom of the container.
 - √ Place reagent bottles on the reagent shelf being sure not to pinch reagent tubes.
 - √ Reagent bottles should be cleaned and replaced monthly regardless of final volume, See ***Routine Maintenance*** for reagent shelf life.
- ❖ ***A default cycle time of 15 minutes for single stream (and 30 minutes for dual stream) will consume 4 liters of reagent every month***

Reagent 1 (R1) — Reducing Reagent

- ❖ Connected to solenoid valve V1
- ❖ 3.25 ml will be used for every test cycle performed

2 Installation

Figure 2.4 – Arrangement of Reagent and Standard Bottles.

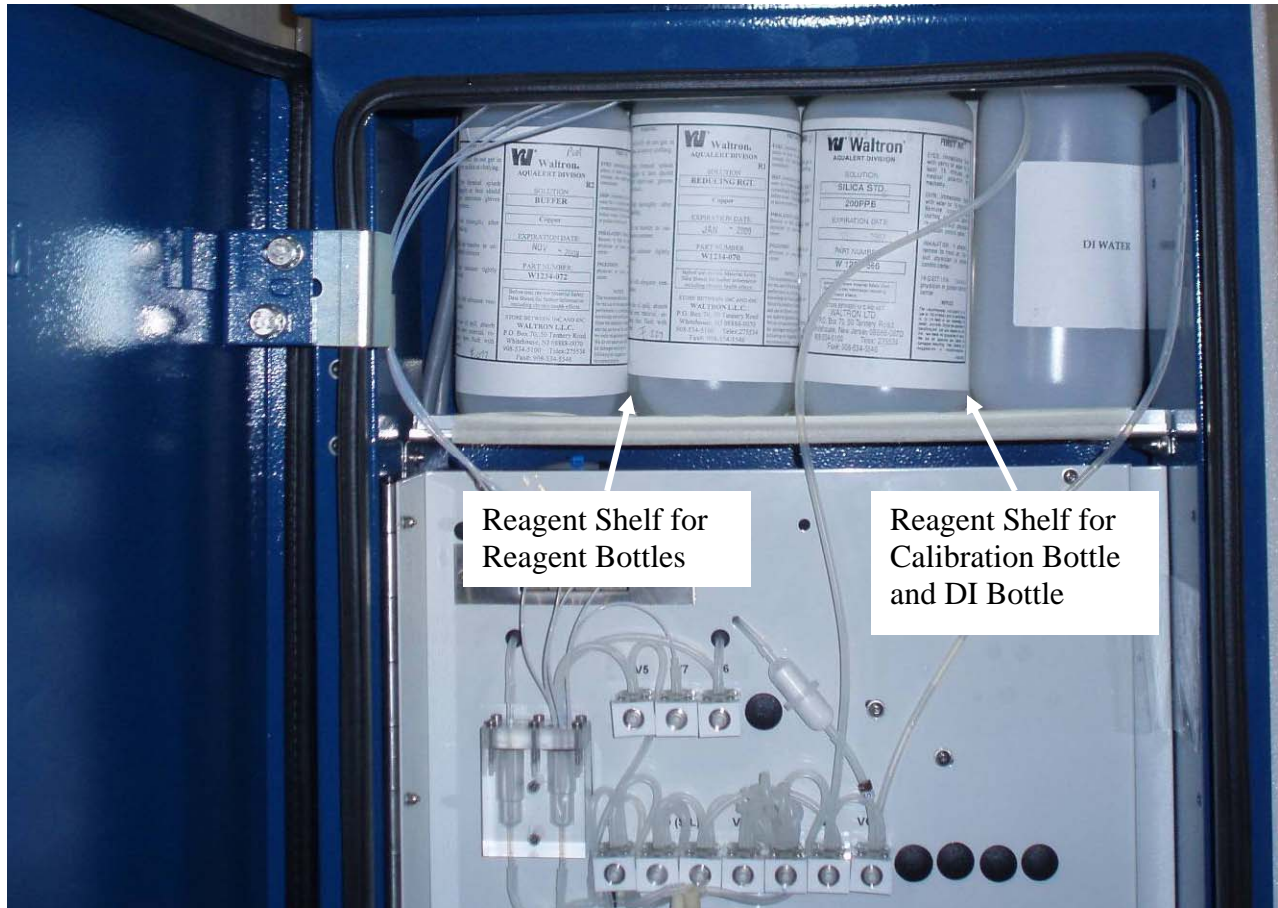

2 Installation



Warning:

- ❖ Before making any installation connections, ensure that the power supply, all high voltage-operated control circuits, high common mode voltage and externally powered alarm circuits are turned off.
- ❖ The power supply earth (ground) on the power junction box **must** be connected for safety reasons and to reduce the effects of radio interference.

2.9 Electrical Layout

The μAI-9041 is comprised of two electronic parts:

- ❖ User Junction Box - separate external box supplied with analyzer.
- ❖ Micro-Processor Unit - electronic compartment of the analyzer.

2.10 User Junction Box - (Figure 2.5)

The user junction box contains a 110/220 VAC to 12 VDC power converter.

Minimum power absorption of 350 mA occurs when the analyzer is in Stand By mode. Maximum absorption during operation is 2 A and the mean absorption in operation is 0.7 A.

A power ON/OFF button is used to turn on 12 VDC to the analyzer. When the analyzer is on, the button will light up and the green Sample LED light located on the display will illuminate.

Figure 2.5 - User Junction Box



2.11 Microprocessor - (Figure 2.6)

The Microprocessor Unit houses the power input (12VDC), analog input processing, microprocessor, alarm and current output generators, and optional serial interface.

Figure 2.6 – Microprocessor Unit

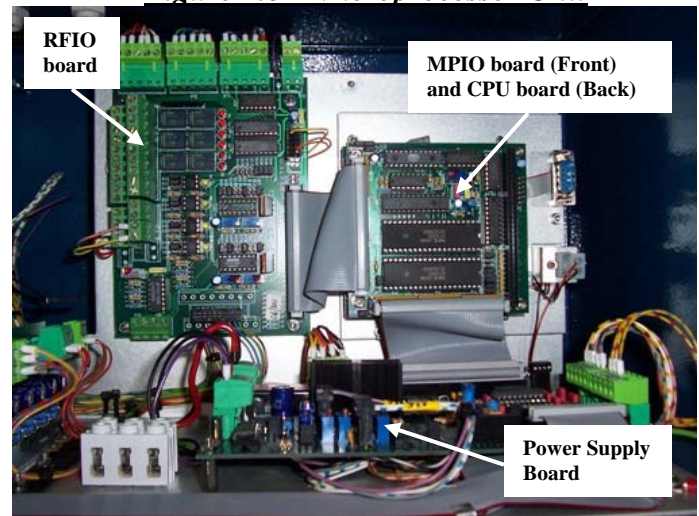

Figure 2.7 – Power Supply Terminal



2 Installation

2.12 Electrical Connections:

❖ Main Power Input – Figure 2.7

1. Feed the three leads from the User Junction Box through the cable entry glands on the top of the analyzer.
2. Attach the three 12 VDC leads into their respective +, GND and - terminal inputs. See *Figure 2.7* on previous page.
3. Connect the main power 110/220 VAC leads to the source power leads (Blue-Neutral, Brown-Line/Hot, Green/Yellow-Ground) from the User Junction Box. (See *Figure 2.5*)
4. Switch on input power by pressing the green button on User Junction Box.



Note: The green Sample LED light located on the display will illuminate when the analyzer has been wired correctly and the junction box has been turned on. Remember to turn off the power (verify that the LED on the display is off) while working inside the Electrical Compartment.

❖ Current Outputs

One current output is supplied for single stream operations. Two outputs are supplied for multi-parameter operations such as silica/phosphate combination units or dual stream analyzers. The most recent current output value will be recorded and used during the next analysis.

To Install Current Outputs:

1. Feed the cable(s) through the holes in the top of the electronic compartment
2. Attach the leads to the RFIO board terminal block P8 (1-Negative out, 2-Positive out). These outputs are set at default range of 4-20mA, but are configurable to 0-20mA and 0/5VDC. (See *Figure 2.8* Below)

❖ Alarm/Relay Contacts:

Alarm is able to be monitored and controlled from a remote location. An alarm may be used to indicate:

1. Busy—Analyzer is in operation
2. Dilution Method
3. High Concentration Alarm
4. Error—(Analyzer is out of sample or out of service)

The following diagram shows the installation of alarm relays and contacts. Refer to *Figure 2.8* for corresponding positions on the RFIO board terminal strip.



2 Installation

Terminal Strip	Relay	Pin	Action:	Description:
<p><u>P3-A</u> Alarm Contact Relays</p> <p>** (Refer to RFIO Board schematic on next page for corresponding terminal positions.) **</p>	K1	1	Busy N.C.	When sampling the analyzer will relay a busy status. This can be used to monitor when the analyzer is sampling or in standby.
		2	Busy N.O.	
		3	Busy COM.	
	K3	4	Cal Error Stream 1 N.C.	When in auto dilution, the analyzer can provide a relay for out of range or auto range configuration.
		5	Cal Error Stream 1 N.O.	
		6	Cal Error Stream 1 COM	
	K5	7	Cal Error Stream 2 N.C.	When in auto dilution, the analyzer can provide a relay for out of range or auto range configuration.
		8	Cal Error Stream 2 N.O.	
		9	Cal Error Stream 2 COM	
	K7	10		
<p><u>P3-B</u> Alarm Contact Relays</p> <p>(Used for single and dual stream units)</p>	K2	1	Error N.O.	Service indication will relay if analyzer is out of sample, contains air in cell, or has any other malfunctioning errors.
		2	Error N.C.	
		3	Error COM.	
	K4	4	High Limit Stream 1 N.C.	Analyzer will trigger alarm when it reads a value above limit set in Parameters Settings (See Programming).
		5	High Limit Stream 1 N.O.	
		6	High Limit Stream 1 COM.	
	K6	7	High Limit Stream 2 N.C.	Analyzer will trigger alarm when it reads a value above limit set in Parameters Settings (See Programming).
		8	High Limit Stream 2 N.O.	
		9	High Limit Stream 2 COM.	
	K8	10		
<p><u>P4-A</u> Input Contacts</p>				NOT USED
<p><u>P4-B</u> Input Contacts</p>				NOT USED
<p><u>P8</u> Current Output Stream 1</p>		1	Negative Out	Current Outputs: 0/5 VDC; 0-20mA, 4-20mA (default)
		2	Positive Out	
<p><u>U6</u> Current Output Stream 2</p>		1	Negative Out	Current Outputs: 0/5 VDC; 0-20mA, 4-20mA (default)
		2	Positive Out	

2 Installation

Figure 2.8 - RFIO Board

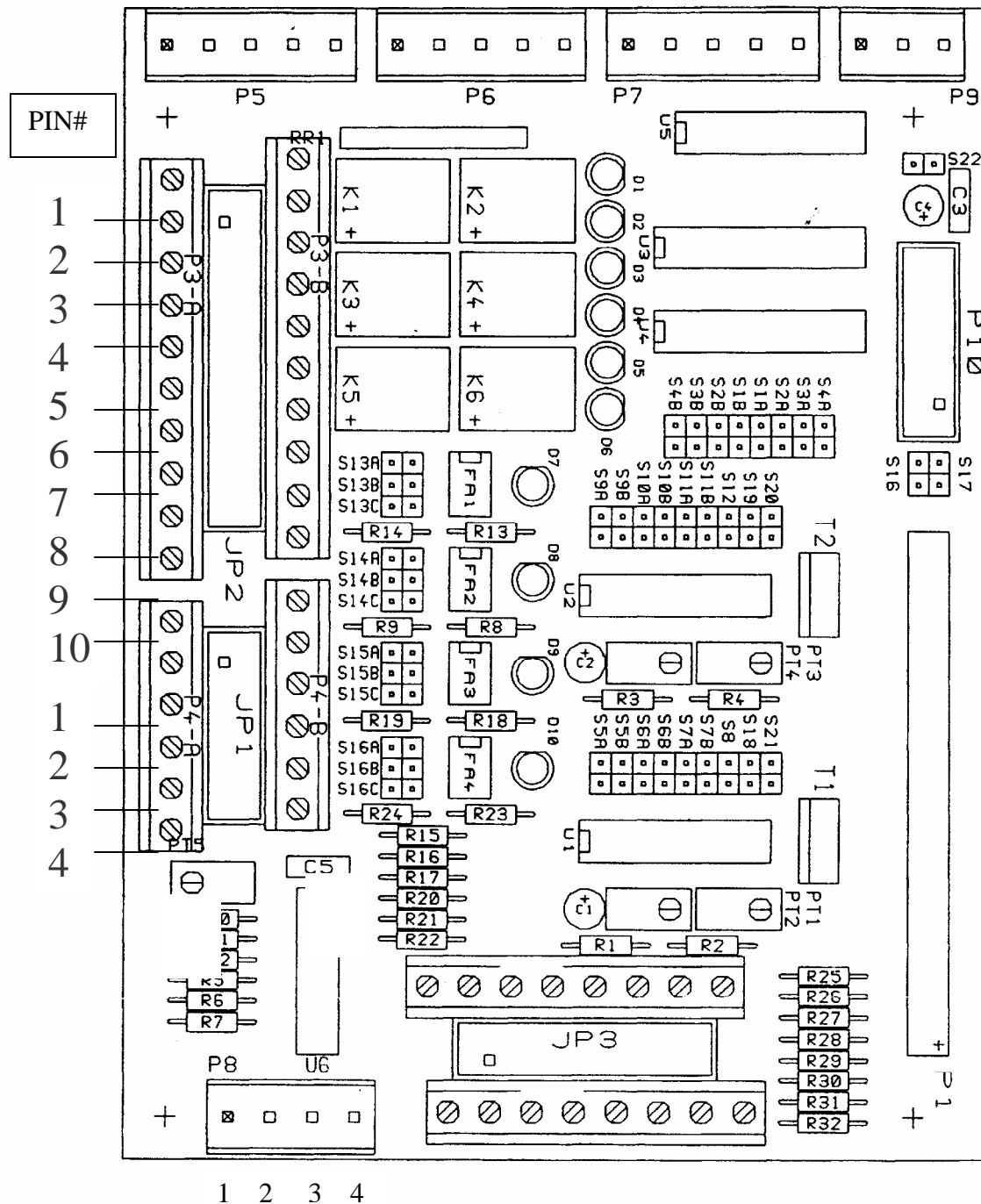

Jumper setting for switching the current output on terminal P8:

For 4-20 mA Output:	S21 ON	S7B ON	S6A ON	S5A ON	
For 0-20 mA Output:	S21 ON	S8 ON	S7B ON	S6A ON	S5B ON

3 Liquid Handling Section-Analytical Compartment

3.1 Principle of Operation

Using the features patented under Loop Flow Analysis, the analyzer is able to measure and interpret the amount of hydrazine contained in a sample stream.

Color reagent is added to the sample and mixing occurs. Based on chemical reaction, a color is formed. The analyzer then reads and records the optical density of the color which is used to determine the amount of hydrazine.

Chemical reaction sequence:

1. Color reagent is added to the system.
2. While controlling temperature, the solution is put in closed loop where mixing occurs and chemical complex is developed.
3. The optical density of the mixed sample is measured continuously during the entire procedure so that a true zero calibration can be performed for every cycle. The optical density can be viewed during the entire process on the display graph. A secondary calibration is achieved by automatically introducing a standard solution of known value.

3.2 General Operation Figure 3.1 and 3.2

- ❖ Sample enters constant head unit situated in the bottom of the analytical compartment behind the hydraulic panel. The constant head unit is fitted with an out of sample switch that, when activated, relays an alarm and puts the analyzer in standby mode.
- ❖ For Multi-Stream Analyzers, each sample inlet is fed into a separate constant head unit complete with float, S-tube and alarm.
- ❖ The sample is taken from the constant head and S tube and flows into the Loop Flow Reactor. The sample is fed to solenoid VC4.

Steps in the LFR:

1. Sample is taken from sample stream and introduced into analyzer. Sample blank measurement and colorimeter zeroing.
2. Reagent injection in chemical reaction sequence.
3. Sample and reagent mixing.
4. Heating (optional).
5. Optical density measurement using a double beam colorimeter.
6. Automatic sample dilution in case of full-scale reading.
7. End point measurement stored in non volatile RAM for remote and local readings.
8. Concentration value calculation based on the correlation with internal calibration factor.

Components in the LFR (Figures 3.1, 3.2):

1. The analytical reactor is made up of three interconnected pieces (mechanical, hydraulics, optical). Together these parts make up the LOOP FLOW REACTOR (LFR).
2. In the case of exceedingly high hydrazine concentrations, the analyzer is still able to perform an analysis by automatically diluting the sample.
3. Status (open or closed) of valve Vs/1 determines if LFR is operating in SAMPLE or LOOP mode. Valve V11(VDil) is activated when a sample dilution is needed.
4. Reagent solenoid valves control the injection of the reagents in the LFR. The pressure change in cylinder C1 mixes reagents and sample.
5. Valve V6, when activated, interrupts the LFR by producing a vacuum inside C1. This vacuum produces the negative pressure needed for reagent introduction.
6. Pump P is a single tube peristaltic pump that can be activated in direct or reverse mode.
7. Status (open or closed) of valves V8 and VC4 determine if sample, diluent or calibrant is flowing.
8. Cylinder C2 holds sample transferred from C1 during the reverse pump/vacuum production process.

3 Liquid Handling Section-Analytical Compartment

Figure 3.1 — Analytical Compartment (Front View):

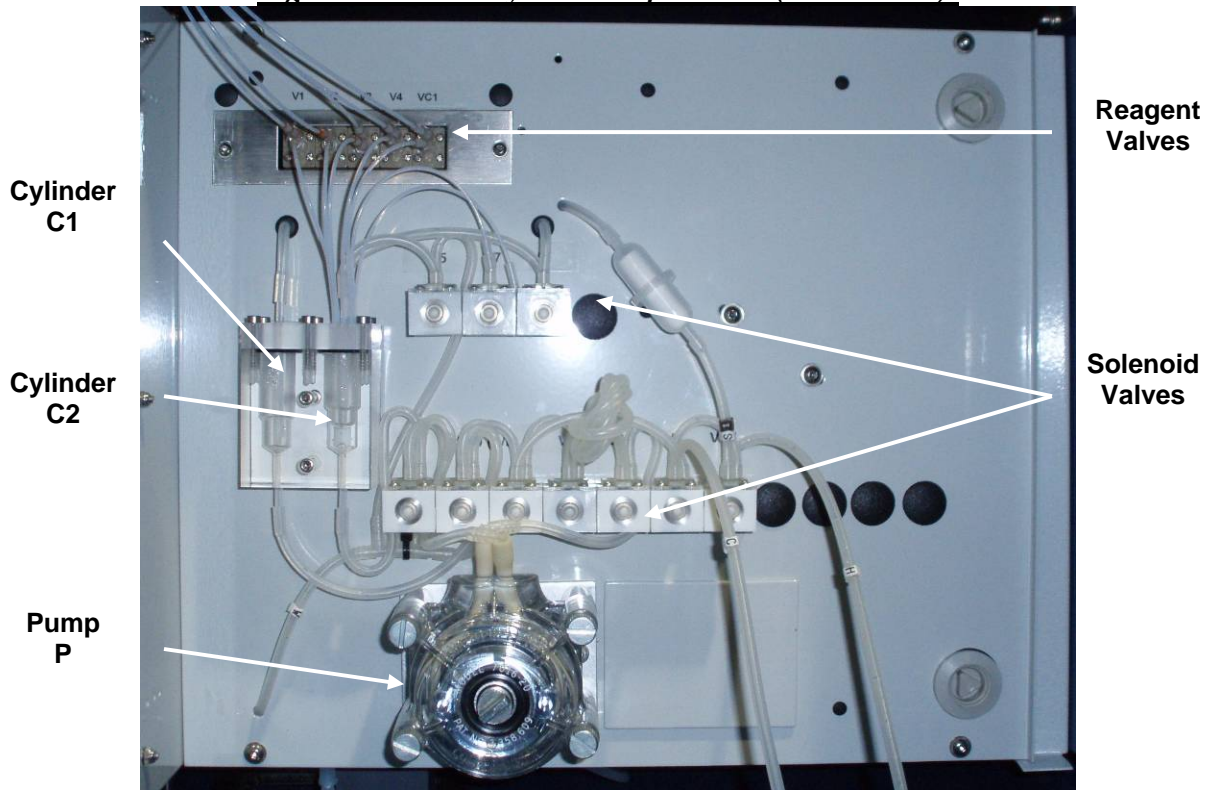
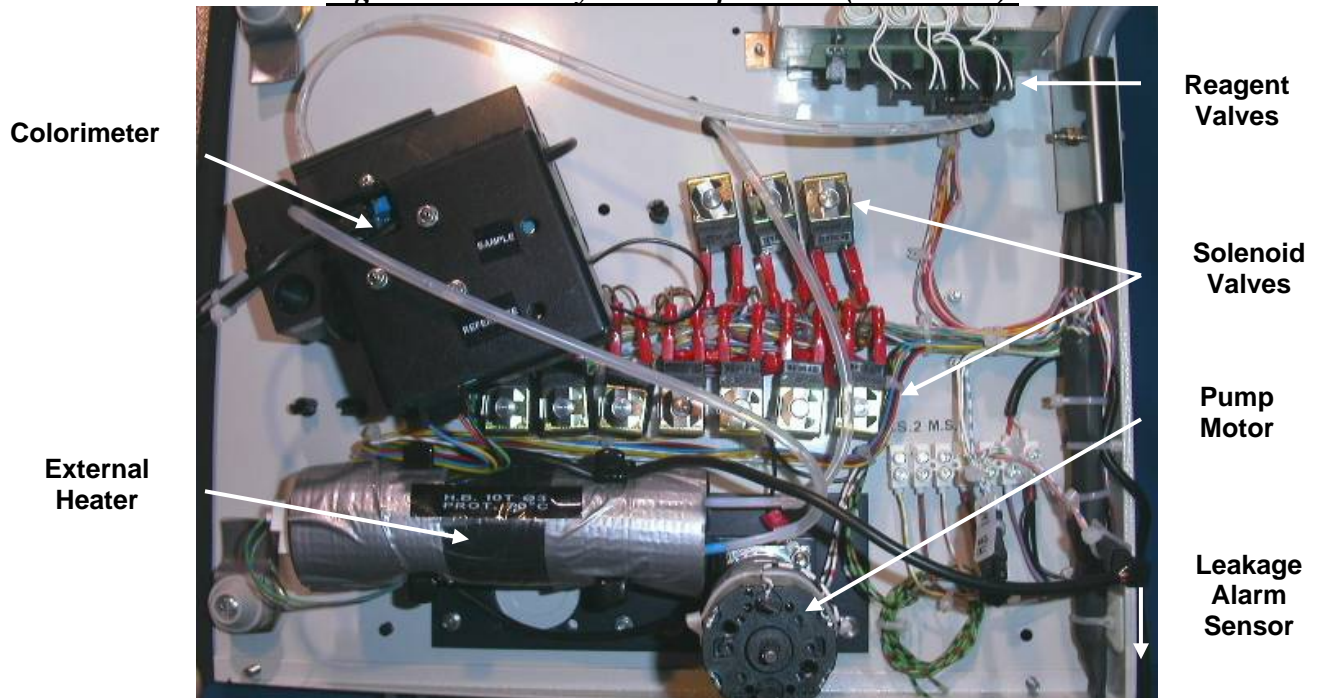
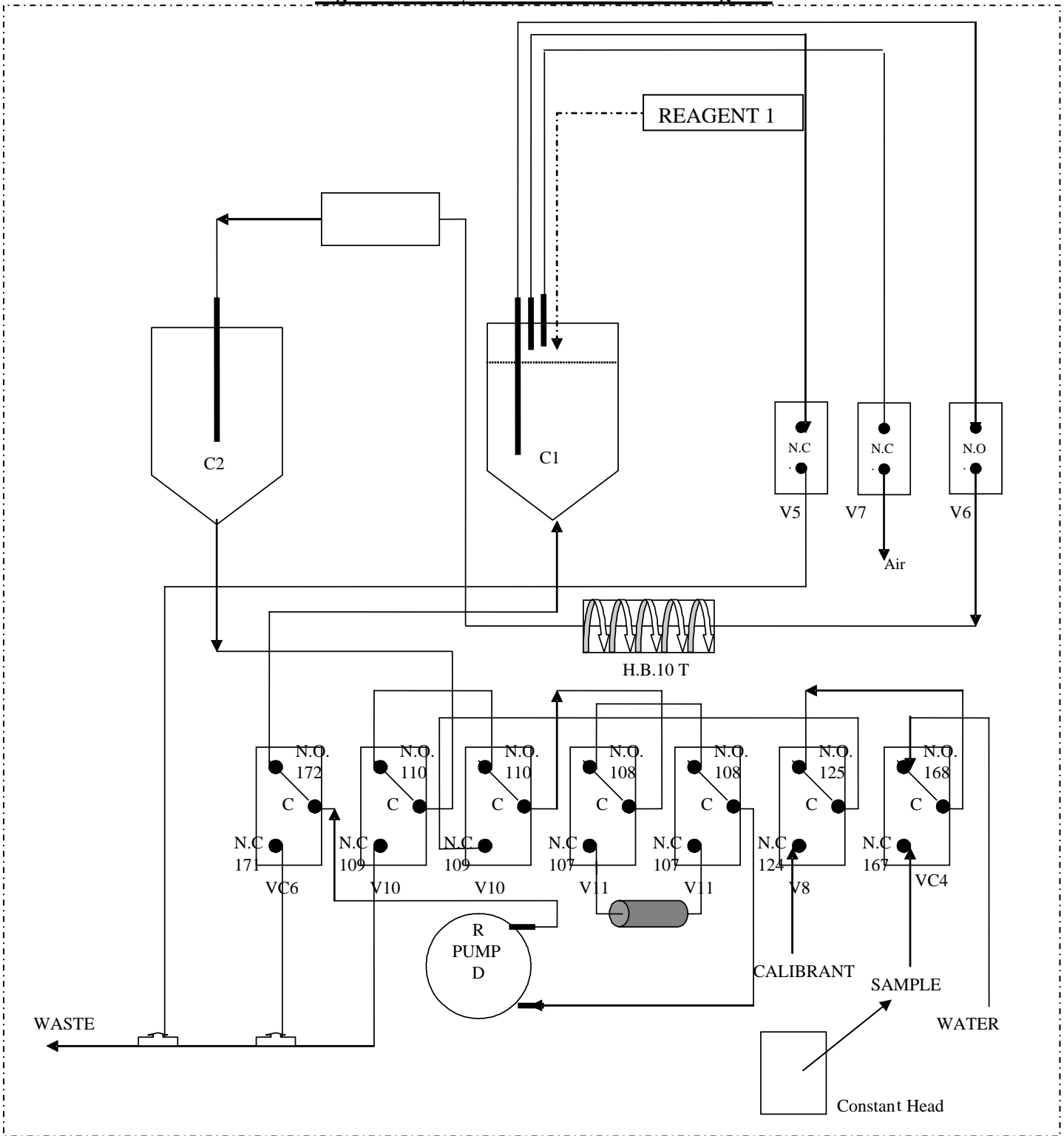

Figure 3.2 — Analytical Compartment (Back View):



3 Liquid Handling Section-Analytical Compartment

Figure 3.3—Hydraulics Interconnect Diagram













4 Display Operation

Display Panel Controls

The analyzer is controlled and programmed using the keys on the display panel. When pressed, the keys activate tactile switches below the display. In the following section (Programming), a step by step procedure is given on how to program the settings and parameters of the analyzer.

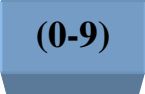
Display Key Functions (See *Figure 4.1*):

-   Press the Power and ON or OFF button simultaneously to turn ON/OFF analyzer.
-  Red LED light illuminates when the analyzer is ON
-  Activates Function menu operation: Stop, Results, Parameters, and General Settings can be accessed through function menu.
-  Used for scrolling through function menu and parameter values or to change between runtime displays, diagnostic information, concentration page, and optical density graph. Also used to clear numeric values.
-  Used for scrolling through function menu and parameter values or to change between runtime displays. Also used for entering decimal point in numbers.
-  Used to backspace while editing values and to return to the previous parameter function.
-  Used to move to the next value in edit mode.
-  Used to enter numeric programming values.
-  Used for storing both programming function parameters and values in the instrument's non-volatile memory.

4 Display Operation:

Figure 4.1: Panel Display Keypad

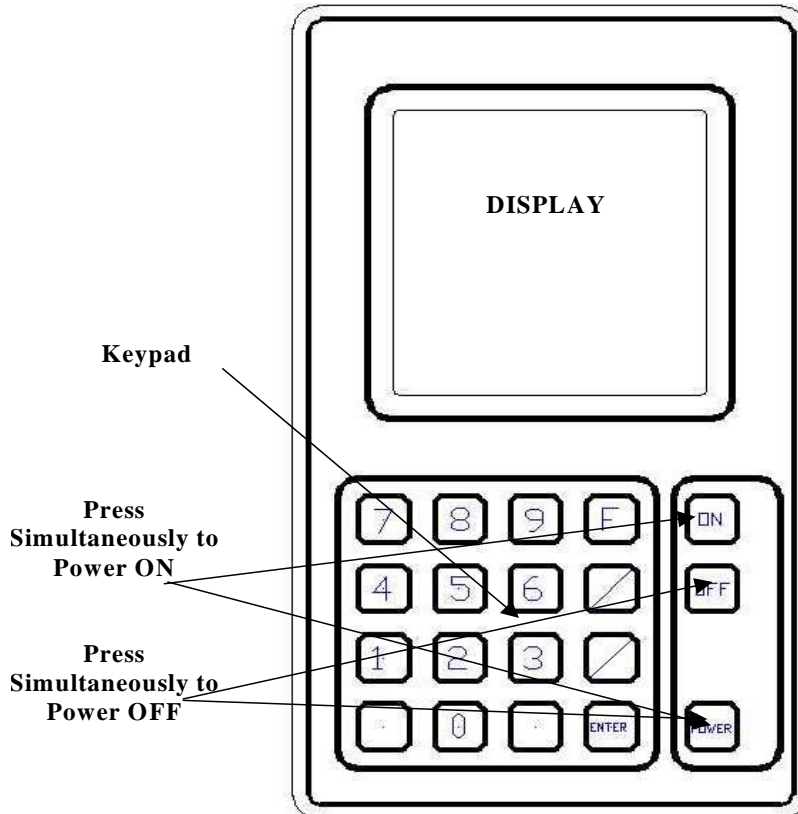

Status Indication:

During operation, analyzer status is indicated on display. Current status is displayed directly below date and time readout on display screen. Each indicator and its significance are listed below:

- Pump-Direct: Indicates pump motor is operating in direct mode.
- Pump-Reverse: Indicates pump motor is operating in reverse mode.
- Sample: Indicates when sampling valves are activated and/or when power is supplied to analyzer.
- Loop: Indicates when program is in loop.
- V1, V2...V11: Indicates when valves used for vacuum production, mixing, dilution and sampling are active.
- Temp. ON: Indicates when heater is on to control sample temperature.
- Low Battery: Indicates when 3.8VDC battery is low.
- Busy: Indicates when analyzer is in busy or standby mode.
- Mixing: Indicates that reagents and sample are being mixed in C1.
- Reaction: Indicates that mixing is complete and final optical density is being determined.

5 Programming

5.1 Programming Flowchart

Figure 5.1

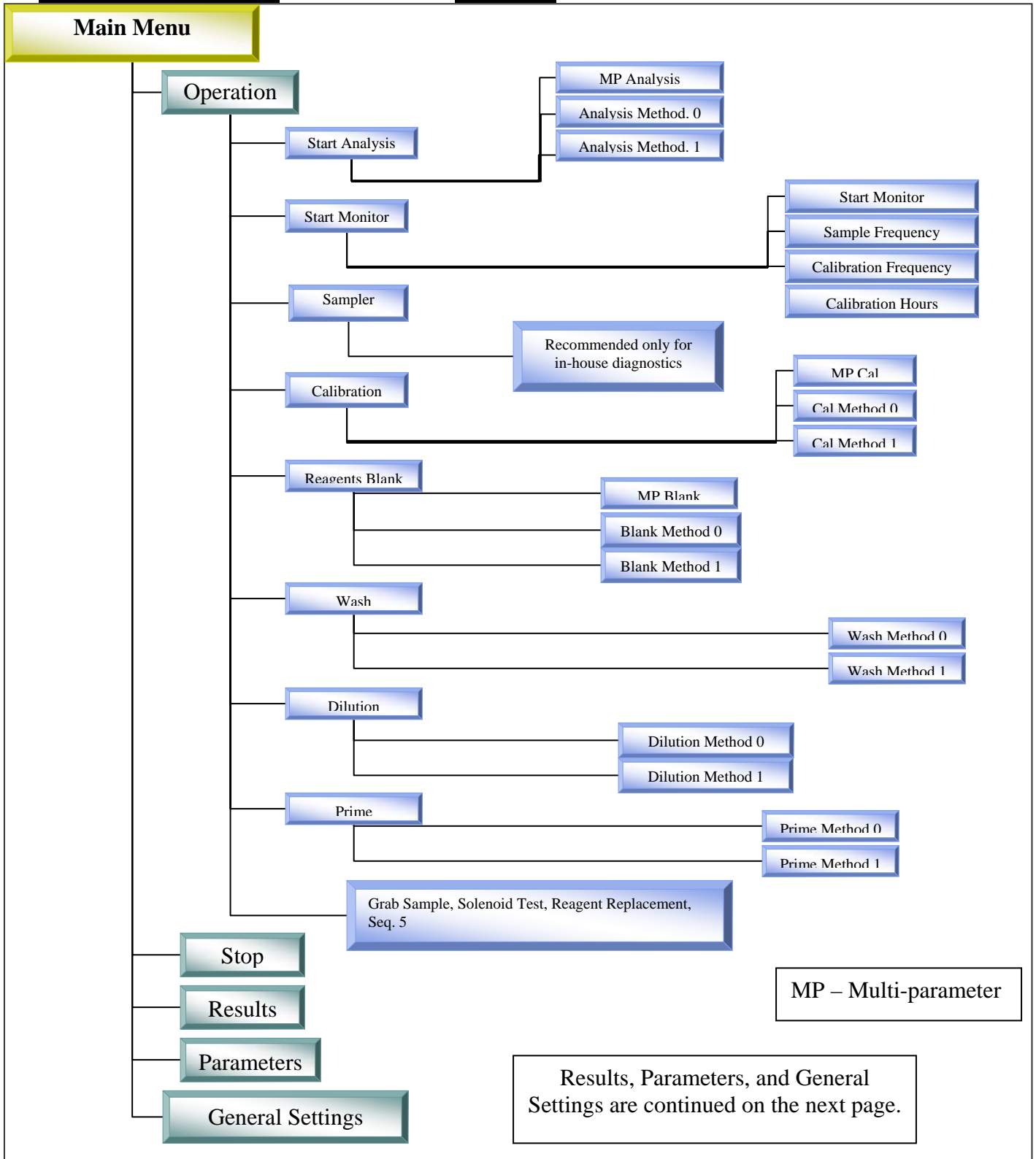

5 Programming

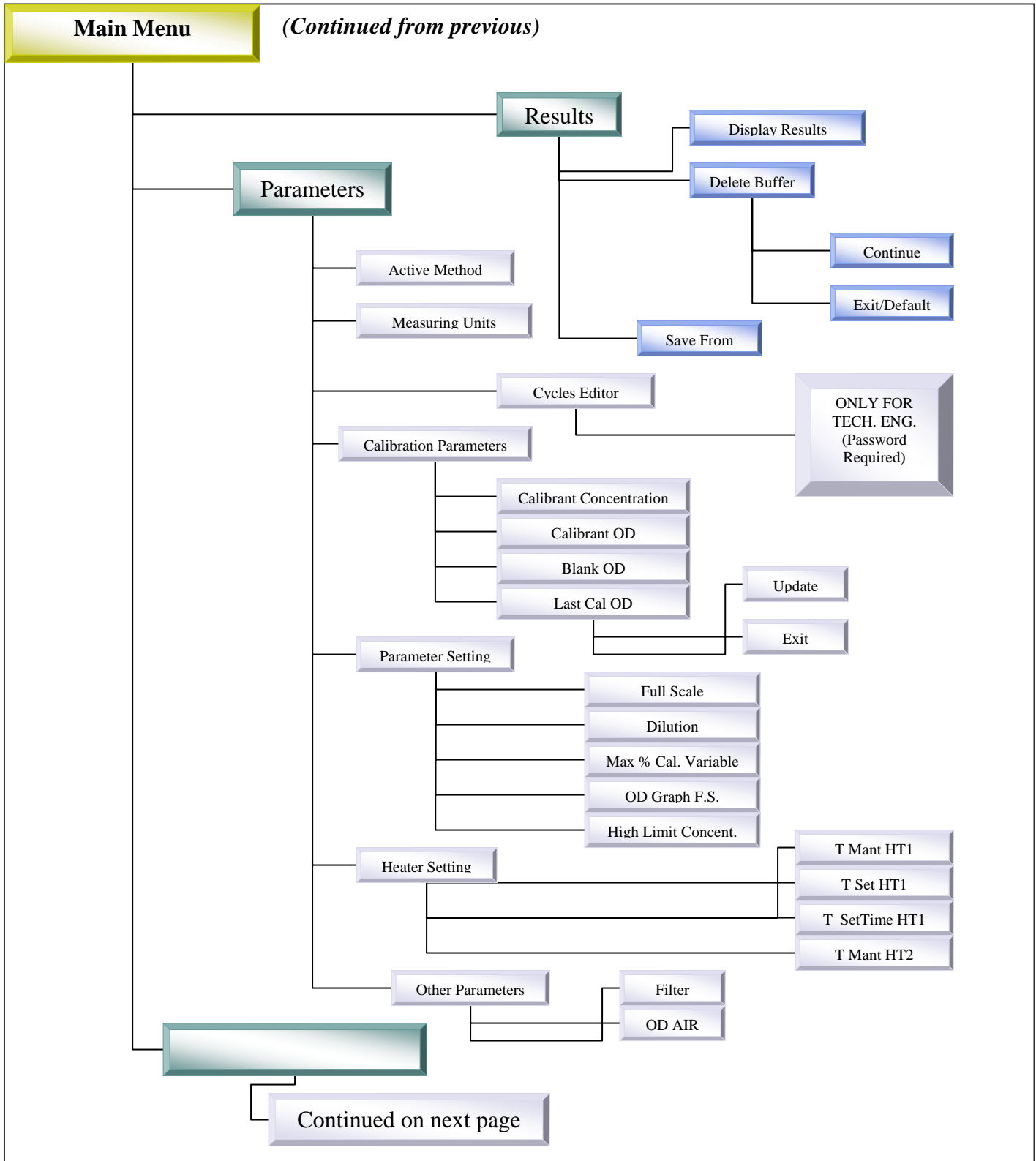

5 Programming

(Continued from previous)

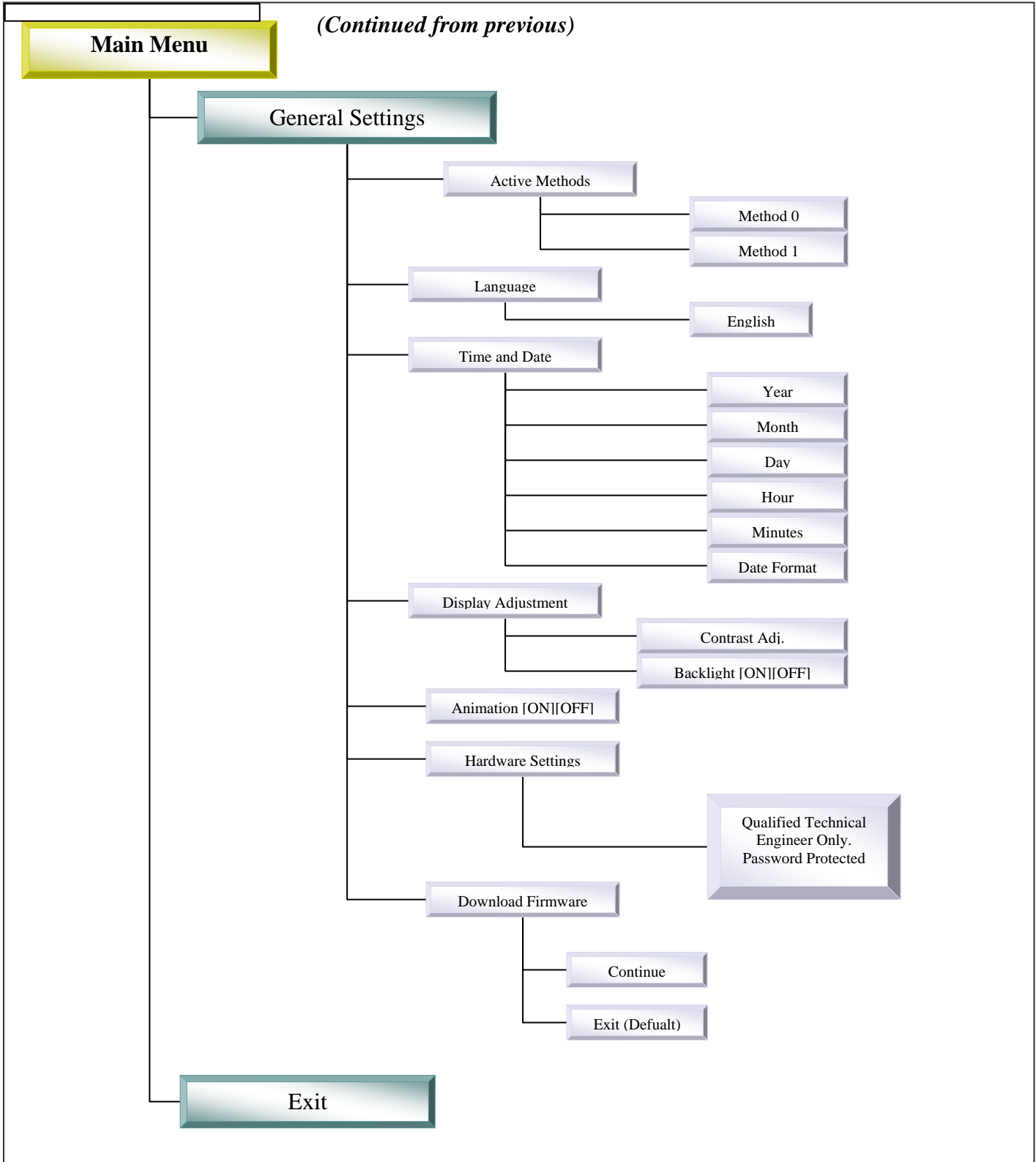

5 Programming

5.2 Main Display Page

While in operation, the panel display output can be changed to show:

1. Display Concentration, Status, OD and Temp Values
2. Optical Density Graph (OD Graph)

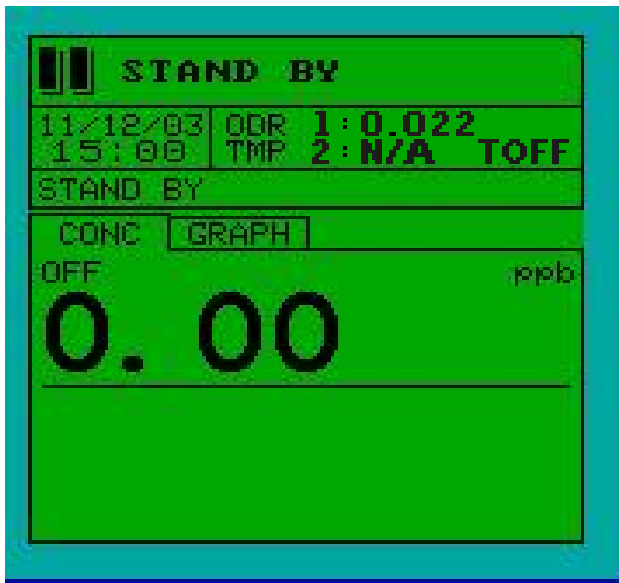

a. Display Concentration

- ✓ Displays sample concentration of the last cycle.
- ✓ Displays analysis method. (HYDR' – first stream, HYDR'' – second stream.)
- ✓ Displays units and time.
- ✓ Shows updated values for both streams at the same time.

b. Optical Density Graph

- ✓ Displays OD graph in real time. Scale can be set in parameters settings
- ✓ Displays analysis method.
- ✓ Displays OD value in real time.

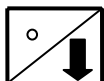

OR



{Advance to the Graph page}

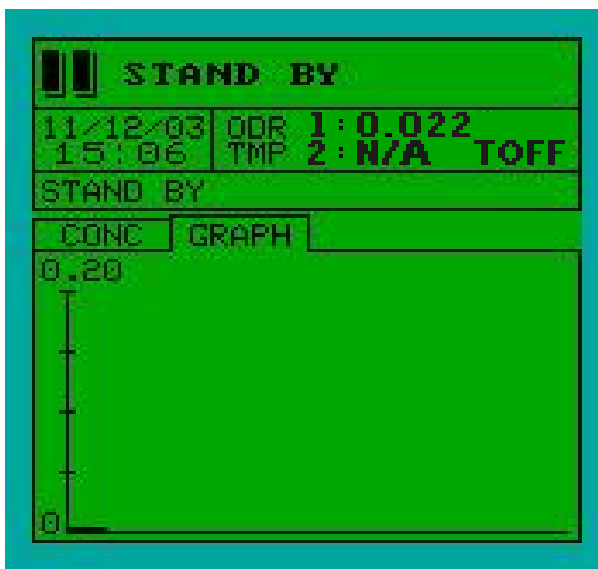

b. Status/OD-Temp Values

- ✓ Indicator icon shows the status of the monitor. (Play symbol = analysis running. Pause symbol = analyzer in standby.)
- ✓ Displays OD, temperature and time for diagnostic troubleshooting.
- ✓ “Missing Sample” and then “Monitor Minutes” is displayed if sample is missing.
- ✓ Displays concentration once the final optical density has been taken.
- ✓ “Monitor Minutes” is displayed to indicate countdown time until next sampling.

5 Programming

5.3 Operating Page: Start Analysis

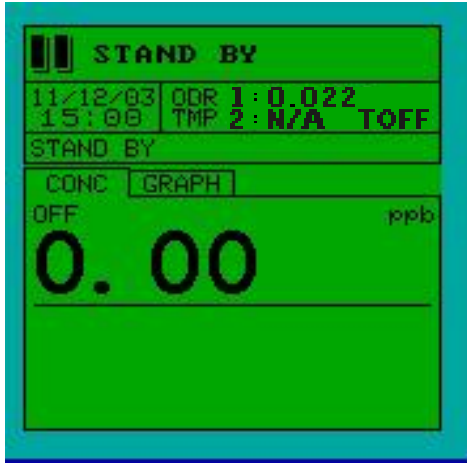

Press [F] to access Operation page. Select Operation using the up/down arrows and press [Enter].



Note: To return the previous menu, press the back arrow button.



Use Start Analysis command to begin a single analysis cycle. **After the one cycle is complete the monitor will enter Standby status.**
For Multi-Parameter analyzers, user must select analysis method and press [Enter].

Display concentration page is displayed when analyzer enters analysis cycle.



Note: To interrupt a cycle, press [F], select STOP, and press [Enter].



5 Programming

5.4 Operating Page: Start Monitor

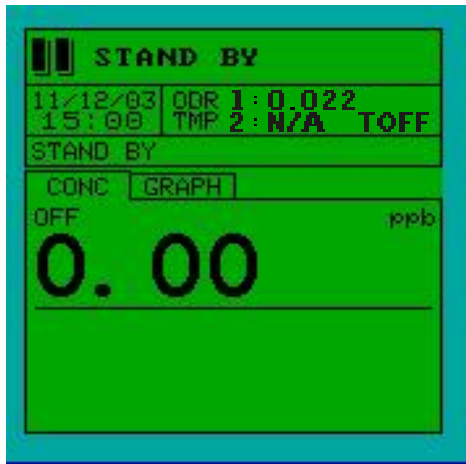

To access Start Monitor page, press [F], select Operation, press [Enter], and select Start Monitor. The analyzer can then be set to monitor sample at user-specified intervals. **The start monitor mode is used for normal and continuous sample analysis.**



Note: A cycle must be finished or stopped before changing parameters or beginning a new cycle.



Note: The analyzer automatically stores the last command selected. Use the up and down arrow to access and change menu options.



Once Start Monitor is selected the analyzer will continually monitor the selected parameter(s) based on the user-defined frequencies and intervals. If the multiple parameter (MP) setting is selected, the analyzer will continuously monitor each parameter one at a time. *(See next section for setting up Start Monitor parameters)*

Once Start Monitor is activated, the main display page will be displayed. See *Section 5.1* for display options.

5 Programming

5.5 Operating Page: Start Monitor Setup

Cont.

STAND BY	
11/12/03 16:56	ODR 1: 0.022 TMP 2: N/A TOFF
START MONITOR	
START MONITOR	
SAMPL. FREQ. (MIN)	0
AUTO PRIME	
CAL TYPE	Cal
CALIB. FREQ. (DAYS)	0
CALIB. HOURS 1	0
CALIB. HOURS 2	0
CALIB. HOURS 3	0

STAND BY	
11/12/03 17:09	ODR 1: 0.022 TMP 2: N/A TOFF
START MONITOR	
START MONITOR	
SAMPL. FREQ. (MIN)	0
AUTO PRIME	
CAL TYPE	Cal
CALIB. FREQ. (DAYS)	0
CALIB. HOURS 1	0
CALIB. HOURS 2	0
CALIB. HOURS 3	0

STAND BY	
11/13/03 12:34	ODR 1: 0.022 TMP 2: N/A TOFF
START MONITOR	
START MONITOR	
SAMPL. FREQ. (MIN)	5
AUTO PRIME	
CAL TYPE	Cal
CALIB. FREQ. (DAYS)	0
CALIB. HOURS 1	0
CALIB. HOURS 2	0
CALIB. HOURS 3	0

STAND BY	
11/13/03 12:43	ODR 1: 0.022 TMP 2: N/A TOFF
START MONITOR	
START MONITOR	
SAMPL. FREQ. (MIN)	15
AUTO PRIME	
CAL TYPE	Cal
CALIB. FREQ. (DAYS)	1
CALIB. HOURS 1	23

To change Start Monitor settings, press [F], select Parameters, select Start Monitor, select desired parameter and press [Enter].

Enter sampling frequency. **Changing the sampling frequency will directly affect the amount reagent consumed.** Default Sample Frequency is 15 minutes for single stream (and 30 minutes for dual stream); at default frequency reagents will last one week.

After the Sample Frequency parameter is selected, use the numeric keypad to enter desired frequency value. Press [Enter] to store the value.

The Auto Prime parameter is used to flush out and update reagent in reagent tubing by automatically initiating a prime cycle.

Automatic prime is performed after analyzer has been left in Stand By mode for a user-specified number of days. To initiate an automatic prime, highlight Auto Prime and set up parameters.

The Cal Type parameter specifies what type of calibration (standard calibration, blank, MP) is performed during automatic calibration.

Cal. Type should always be set at "Cal".

To change Calibration Frequency, select Parameter and use the numeric keypad to enter desired value. A default calibration frequency of 7 days is recommended and will consume 1 L of standard per week.

- ✓ If 0 is entered, the analyzer will perform multiple daily calibrations.

To set time-specific daily calibration, enter the desired time in Calibration Hours (0-23).

- ✓ For multiple daily calibrations: Enter first calibration time in Calibration Hours 1, second calibration time in Calibration Hours 2 and so on.
- ✓ Entering 24 will disable time-specific calibration.

5 Programming

5.6 Operating Page: Calibration Page

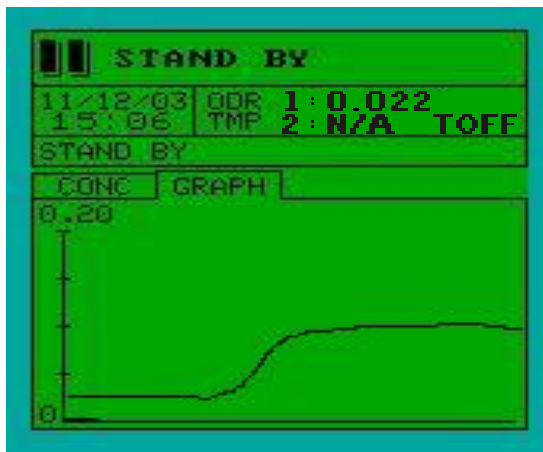

Sampler Mode is not recommended for analysis, and should be used only for in-house diagnostics.



Note: Before beginning a calibration:

- ✓ Set calibration parameters in the Parameters section. (Failure to set parameters may result in a failed calibration.)
- ✓ Check calibration standard to ensure adequate amount of solution (>250ml). Make sure standard bottle is connected to calibration (C) tube.

To access Calibration page, press [F], select Operation, press [Enter], and select Calibration. *For Multi-Parameter users, the method selection page will be displayed. Select desired calibration parameter (HYDR', HYDR'') and press [Enter]. MP calibration indicates that all active methods will be calibrated.*

Calibration is successful if “CAL OD: #####” is displayed. If analyzer does not pass calibration, “Calibration Fail” will be displayed. A successful CAL OD for a 50ppb hydrazine standard should be in the range 0.150-0.200.



Note: During a sample or calibration cycle the optical density graph should:

- ✓ Approach zero as the “zeroing of the colorimeter” is performed.
- ✓ Climb steadily and plateau after all reagents have been injected and the hydrazine complex has formed.

5 Programming

5.7 Operating Page: Reagents Blank

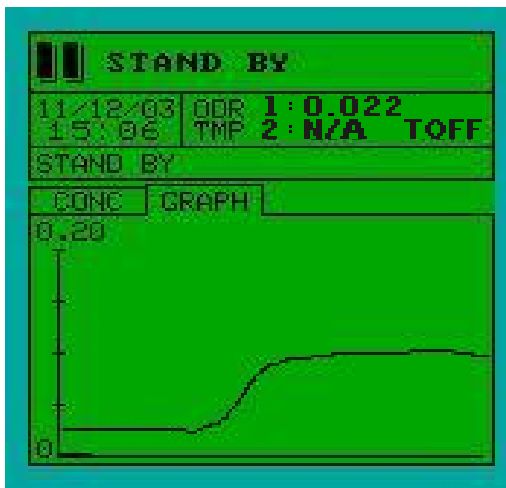

Note: Before beginning a Reagent Blank, the user must:

- ✓ Perform a reagent Prime and Wash. (Only necessary if the reagents have been changed.)
- ✓ Place the H-Tube in deionized (silica-free) water.

To access Reagents Blank page, press [F], select Operation, press [Enter], and select Reagents Blank. A reagent blank will then be performed by measuring the optical density of the hydrazine contained in the reagents and de-ionized water.

A reagent blank should be performed every time reagents are changed. After changing reagents, the new optical density value should not differ from the old one by more than 30%. Old and new OD values can be compared by viewing the last blank OD displayed in the Calibration Parameters Page. *For Multi-Parameter users, the method selection page will be displayed. Select desired reagent blank parameter (HYDR', HYDR'') and press [Enter]. MP blank indicates that all active methods will be blanked.*

Once a Reagent Blank cycle has been initiated, the main display page will be displayed.



Note: During a reagent blank cycle the

OD graph should:

- ✓ Climb and jump around while air bubbles are purged and reactor is washed.
- ✓ Approach zero and plateau as the blank reading is taken.

5 Programming

5.8 Operating Page: Wash

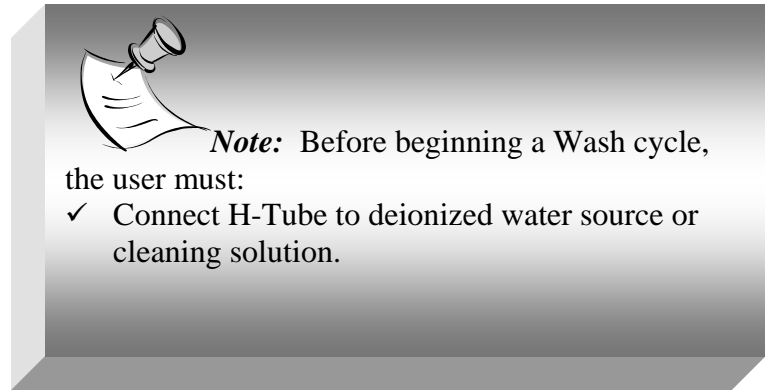
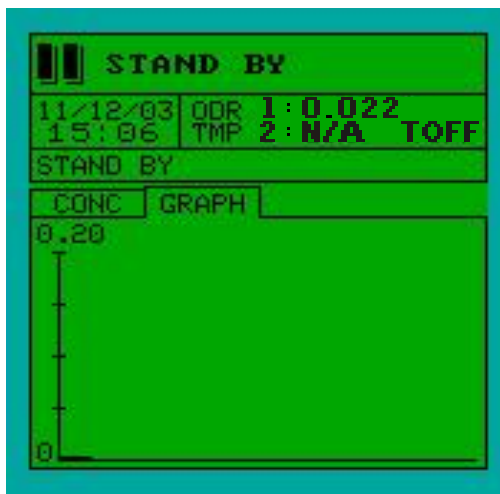
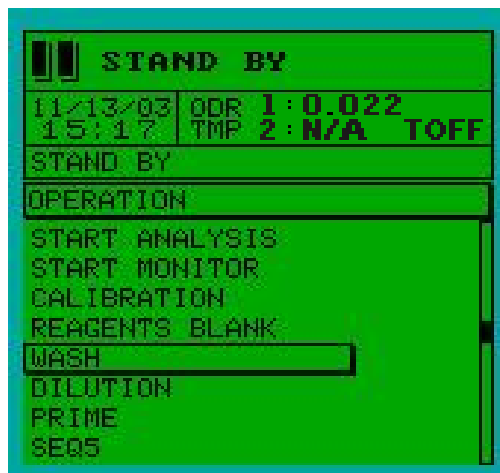

To access Wash page, press [F], select Operation, select Wash, and press [Enter].

During the wash cycle, the analyzer draws deionized water in through the H-tube and flushes the LFR (Loop Flow Reactor). A wash cycle can be used to:

- ✓ Clean the analyzer with cleaning solution.
- ✓ Flush out contaminated sample and prepare for a calibration or reagent blank.

Once a Wash Cycle has been initiated, a wash display page will be displayed until cycle is completed.

The Wash cycle will rinse and fill the LFR with deionized water.

All main display pages are accessible during Wash cycle.

5 Programming

5.9 Operating Page: Dilution

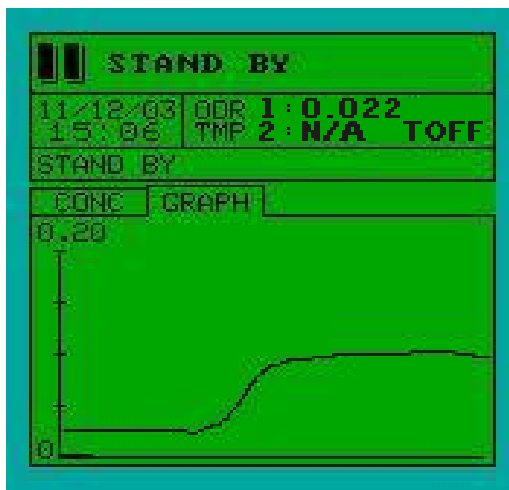

Note: Before beginning a Dilution cycle, the user must:

- ✓ Connect H-Tube to deionized water source
- ✓ Setup Dilution Factor (See Startup Section)

To access Dilution page, press [F], select Operation, select Dilution, and press [Enter].

The analyzers auto-dilution feature is used to measure high hydrazine sample concentrations. The analyzer automatically recognizes exceedingly high concentration levels and performs a dilution process by adding deionized water to the sample. This process ensures that the analyzer is capable of operating correctly at both high and low hydrazine concentrations.



Dilution cycle sequence of events:

- ✓ Sample (high hydrazine concentration) is aspirated through dilution loop. Sample is isolated and held in dilution loop tubing.
- ✓ Deionized water is used to flush high concentrate sample out of LFR system.
- ✓ Deionized water fills LFR and the sample from dilution loop is mixed and diluted.
- ✓ Optical density of diluted sample is taken and dilution factor is used to yield a final concentration value.

5 Programming

5.10 Operating Page: Prime

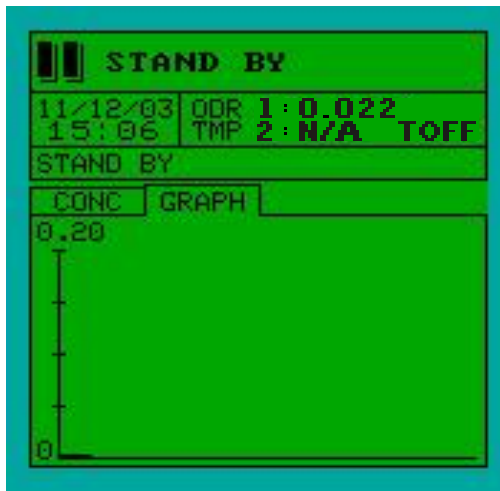

Note: Before beginning a prime cycle, the user must:

- ✓ Connect all reagents to their respective containers.
- ✓ Connect sample stream and deionized water (H-tube) to analyzer.

To access Prime page, press [F], select Operation, select Prime, and press [Enter].

During the Prime cycle, sample or deionized water is aspirated into the LFR where vacuum production occurs and reagents are injected. This procedure updates reagent lines and purges air out of reagent injection system. The analyzer is now ready for reagent blank and calibration.

Customization Cycle (Seq. 5)

To access Customization page Seq. 5 press [F], select Operation and scroll down. These functions are used for troubleshooting and specialized programming customizations such as cycle editing. Only qualified Waltron representatives should access and edit customization pages.

5 Programming

5.11 Operating Page: Grab Sample

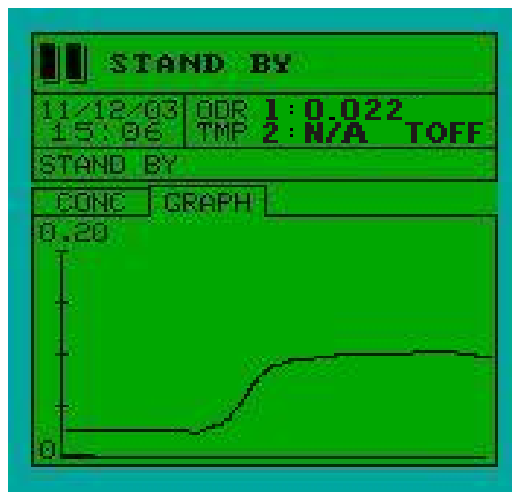
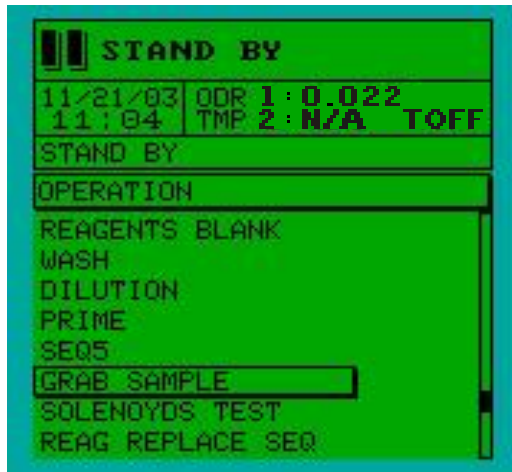

Note: Before beginning a Grab Sample cycle, the user must:

- ✓ Connect all reagents to their respective containers.
- ✓ Remove calibration tubing (C) from calibration solution and place calibration tubing (C) in container containing grab sample.

To access Grab Sample page, press [F], select Operation, select Grab Sample, and press [Enter].

Grab Sample cycle can be used as a QA/QC check. Once analyzer begins Grab Sample, the concentration page is displayed.



Note: During a grab sample cycle the optical density graph should:

- ✓ Approach zero as the “zeroing of the colorimeter” is performed.
- ✓ Climb steadily and plateau after all reagents have been injected and the hydrazine complex has formed.

5 Programming

5.12 Operating Page: Solenoid Test



To access Solenoid Test page, press [F], select Operation, select Solenoid Test, and press [Enter].

Solenoid Test cycle activates all solenoids individually in sequence. User must manually check to make sure each solenoid activates correctly. Reagent solenoids (V1, V2, V3, V4, V5) can be checked by listening to “click” sound during activation. Flow direction control solenoids (white square solenoids) have a white pin in front that switches position when valve is activated.

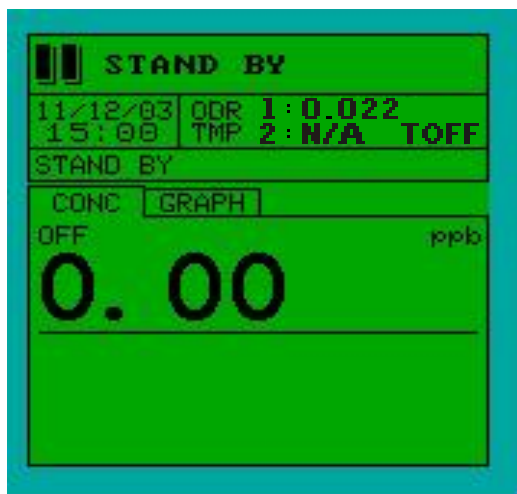

5 Programming

5.13 Operating Page: Reagent Replacement

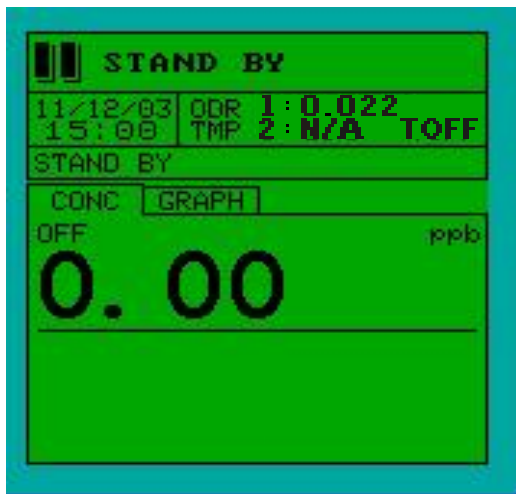

Note: Before beginning a Reagent Replacement cycle, the user must:

- ✓ Connect all reagents to their respective containers.
- ✓ Connect H-Tube to deionized water source.
- ✓ Connect S-Tube to sample stream through constant head unit.
- ✓ Set calibration parameters in the Parameters section. (Failure to set parameters may result in a failed calibration.)
- ✓ Check calibration standard to ensure adequate amount of solution (>250ml). Make sure standard bottle is connected to C-tube.

To access Reagent Replacement page, press [F], select Operation, select Reagent Replacement, and press [Enter].

The Reagent Replacement cycle will run the following in sequence:

- Wash
- Prime
- Calibration

Calibration is successful if “CAL OD: Value” is displayed. If analyzer does not pass calibration, “Calibration Fail” will be displayed.

5 Programming

5.14 Operating Page: Results Page

To access Results page, press [F], select Results, and press [Enter].

Access Display Results to view analysis results stored in analyzer memory. Use Up/Down arrows to scroll through result buffers (0-400).

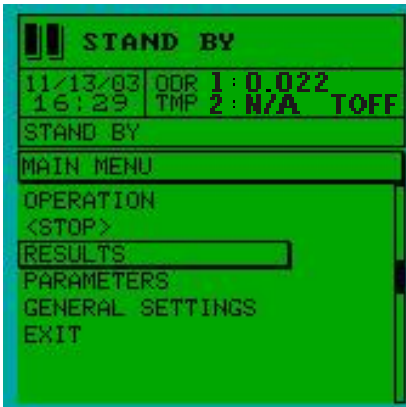

The Display Results page (located in Results menu) is used for:

- ✓ Viewing stored data information for last 400 readings.
- ✓ Displaying all calibrations and blanks performed within the 400 readings.
- ✓ Troubleshooting diagnostic information – such as locating exact time and cycle an error occurred.

Important Analysis and Diagnostic Information Contained within Results Buffer Memory:

- ❖ Indicates method performed
- ❖ Indicates date & time reading was taken
- ❖ Indicates cycle number stored in the circular buffer memory.
- ❖ Indicates concentration value calculated from zeroing, blank, and calibration.
- ❖ Indicates starting optical density and ending optical density. (Useful in troubleshooting.)

Use the GoTo command to jump to specific buffer location.

To delete buffer memory, select Delete Buffer Memory on Results page, and press Continue. Use the Save From command to select the starting buffer memory location.



5 Programming

5.15 Parameter Pages: Basic Set-up

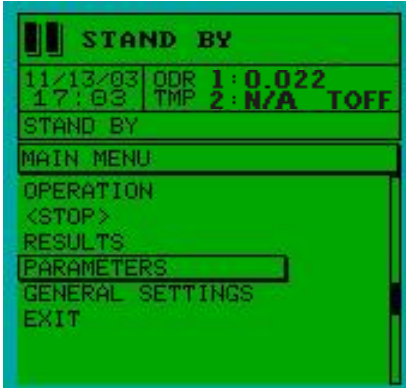

To access Parameters page, press [F], select Parameters, and press [Enter].

The parameter setup options:

- ✓ Measuring Units
- ✓ Cycles Editor

Calibration parameters setup options:

- ✓ Monitor Parameters (Parameter Settings)
- ✓ Heater Parameters
- ✓ Other Parameters

To change or edit parameters specific to analysis method, user must first select desired method (HYDR', HYDR'') and then change parameters individually.

- ✓ Press **ENTER** to edit parameter setting.
- ✓ Press **DOWN ARROW** or **UP ARROW** to advance to the next parameter.

Available measuring units:

- ✓ mg/l
- ✓ ppb
- ✓ g/l
- ✓ ppm

Only Qualified Waltron Representative will be able make changes to cycles editor parameters.

An access code is required to make changes to cycles editor.

5 Programming

5.16 Parameter Pages: Calibration Parameters



To access Calibration Parameters page, press [F], select Parameters, select Calibration Parameters and press [Enter].

Calibration parameters need to be set before attempting a calibration. Before setting calibration parameters the user must:

- ✓ Establish approximate measuring range for parameter and sample measurements.
- ✓ Have fresh standard and reagents ready for calibration.
- ✓ Perform all necessary monthly maintenance procedures.

- ✓ Press **ENTER** to edit the parameter
- ✓ Press **DOWN ARROW** or **UP ARROW** to advance to the next parameter.

Method Type should always remain at default setting of Color.

Calibration concentration is the concentration value of the calibrating standard. *Make sure calibration concentration and standard measuring units are the same.*

Calibrant OD and Blank OD are the optical density values used in measuring sample concentration. Any changes made to OD values will directly affect sample readings.

The Last Cal OD value should be very close to the Calibrant OD, unless the last calibration attempt failed. If the two do not match, the Last Cal OD can be entered manually by selecting it, pressing [Enter], entering OD value and pressing [Enter].

5 Programming

5.17 Parameter Pages: Parameters Setting

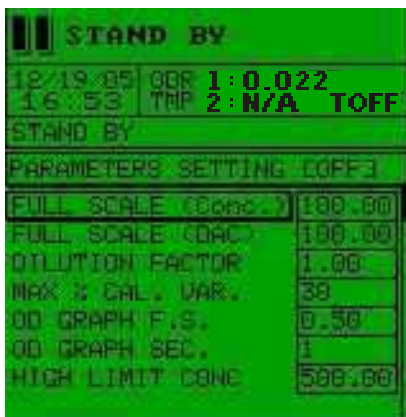

To access Parameters Setting page, press [F], select Parameters, select Parameter Settings and press [Enter].

- ✓ Press **ENTER** to edit parameter.
- ✓ Press **DOWN ARROW** or **UP ARROW** to advance to the next parameter.

Parameters Descriptions:

- 1) **Full Scale (Conc.)**
 - a) Sets normal analysis measuring range.
 - b) Analyzer will perform auto dilution (if enabled) for values exceeding set value.
- 2) **Full Scale (DAC)**
 - a) Value sets current output scale and range. (For 200ppb: 4mA current output at 0ppb and 20mA current output at 200ppb.)
- 3) **Dilution Factor:**
 - a) Value is calculated after dilution calibration; it is the multiplier during dilution cycle.
 - b) A 40cm dilution tube will have a Dilution Factor between 9 and 13.
- 4) **Max % Cal. Var.**
 - a) Maximum % error the analyzer will accept during calibration cycle. Error Cal Alarm will be active until successful calibration.
- 5) **OD Graph F.S.**
 - a) Time scale (in seconds) used for optical density display graph
- 6) **OD Graph**
 - a) Graph interval setting in seconds.
- 7) **High Limit Conc.**
 - a) Alarm will sound if limit is exceeded.
- 8) **High Limit Blank**
 - a) Alarm will sound if limit is exceeded.
- 9) **Low Limit Blank**
 - a) Alarm will sound if limit is exceeded.

5 Programming

5.18 Parameters Pages: Heater Setting & Other Parameters

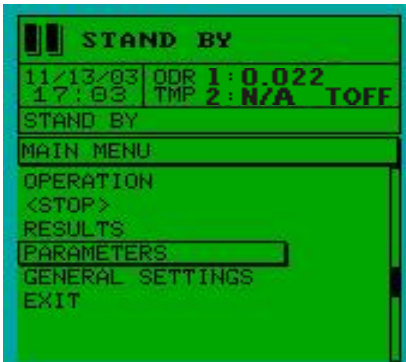

To access Heater Setting and Other Parameters pages, press [F], select Parameters, select Heater Settings or Other Parameters and press [Enter].

Heater Setting and Other Parameters pages are programmed for general use and require no adjustments. Descriptions of Heater Settings and Other Parameters are given below in case operating conditions require adjustments.

NOTE: Heater is NOT required for hydrazine analysis.

Heater Setting parameters:

- 1) **T MANT HT1**
 - Maintains temperature in heating block 1. (Not available on this 9044 version.)
- 2) **T Set HT1**
 - Sets temperature in heating block 1. (Not available on this 9044 version.)
- 3) **T SETIME HT1**
 - Sets time for working temperature. (Not available on this 9044 version.)
- 4) **T MANT HT2**
 - Maintains temperature in heating block 2. (Not available on this 9044 version.)

To toggle the temperature display between heating block 1 and heating block 2, from the Main Display Page press the left/right arrows.

Other Parameters:

- 1) **Filter**
 - Filters analysis readings; used for averaging.
 - Default = 10 provides faster response times and greater sensitivity.
- 2) **OD Air**
 - Value used to activate Air In Cell alarm. Activates due to high OD reading from air in cell. Protective alarm used to relay loss of sample. Default = 1.

5 Programming

5.19 General Settings:



To access General Settings page, press [F], select General Settings, and press [Enter].

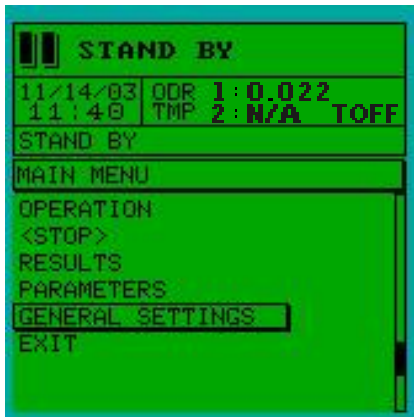

General Settings parameters:

1) Active Methods

- Used during multi-parameter (MP) analysis only. Multi-parameter users only monitoring one method at a time should press [Enter] and select analysis method (Hydr', Hydr'').

2) Language

- English

3) Time and Date

- a) Year: (2###) - Set current year
- b) Month: (1-12)
- c) Day: (1-31)
- d) Hour: (0-23)
- e) Minutes: (0-60)
- f) Date Format: (D/M/Y or M/D/Y)

4) Display ADJ.

- Display contrast adjustment. Use Up/Down arrows to change contrast.
- Backlight (On/OFF)

5) Animation - Not available in 9044 version.

6) Printer – Serial port (ordered separately).

7) Hard. Settings – Waltron use only.

8) Download Firmware:

- New firmware versions can be downloaded using serial port located inside electronics.

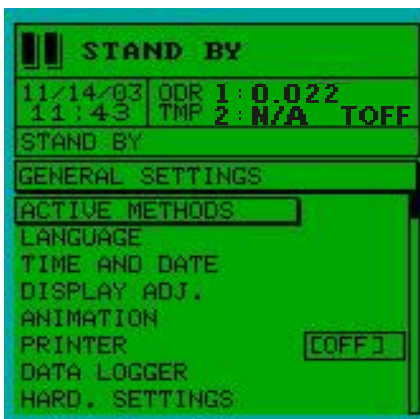

6 Start-up

6.1 Pre-Startup Checklist:

- ✓ Connect calibration tube to calibration bottle.
- ✓ Connect sample tube to constant head unit. Turn on sample flow between 150-200 ml/min..
- ✓ Connect waste tube to contaminated waste drain.
- ✓ Connect deionized water tube to full bottle of deionized water.
- ✓ Fill reagent containers and insert reagent tubes into their respective reagent containers.
- ✓ Supply power to μAI 9044 Hydrazine Analyzer.

6.2 Startup Checklist

- ✓ Perform Reagent Prime (3-5 min). (*Section 5.10*)
- ✓ Perform Wash Cycle (3-5 min). (*Section 5.8*)
- ✓ Setup Parameter Settings. (*Section 5.15*)
 - i) Select the Active Method for operation.

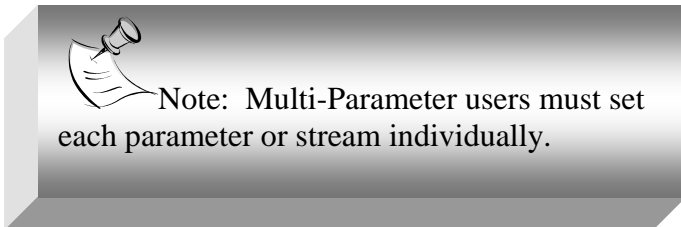

- ii) Set Full Scale range to accommodate working sample concentration and desired 4-20mA current output range.
- iii) Set the High limit alarm setting.

6.3 Reagent Blank:

- ✓ After completing a Reagent Prime and Wash Cycle, perform a Reagent Blank. (*Section 5.7*).

During this cycle, calibration is performed to determine the amount of background hydrazine in the reagents and deionized water. The OD should be close to zero.

6.4 Calibration:

- ✓ Setup Calibration Parameters: (*Section 5.16*)
 - i) Select active method
 - ii) Enter the calibration standard concentration. Keep in mind that the standard supplied by Waltron may not fit the needs of the user. A solution standard can be purchased from Waltron so that a custom standard can be prepared.
 - iii) Set Calibration OD. Calibration OD number should change linearly with the change in calibrant concentration.
- ✓ Perform calibration (*Section 5.6*)

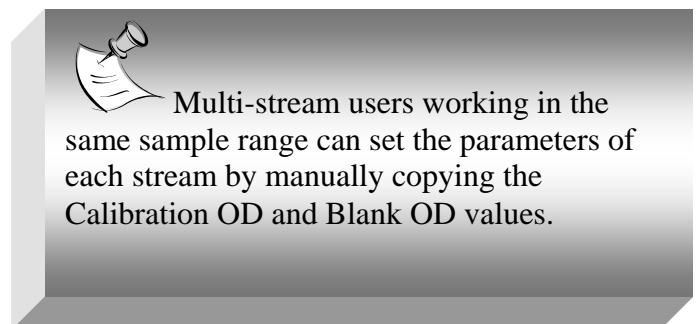
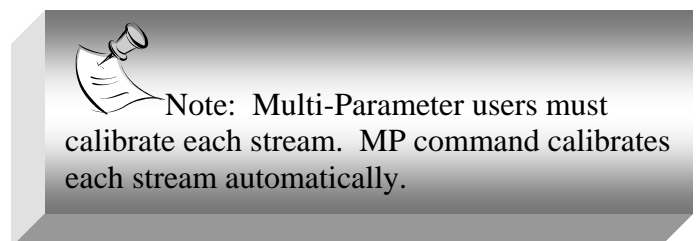

6 Startup

6.5 Dilution Factor Calculation:

The analyzers auto-dilution feature automatically recognizes exceedingly high concentration levels and performs a dilution process by adding deionized water to the sample.

Dilution Factor calculation should only be performed when value of dilution factor is in serious doubt, or if overall system volume is changed.

- ✓ In Parameter Settings, enter 1 as the dilution factor value. (*Section 5.17*)
- ✓ Prepare calibration standard that has a value (D) in desired dilution range. Disconnect S-tube (sample) and place it in standard solution.
- ✓ Make sure deionized water bottle is full and connected to H-tube.
- ✓ Start a Dilution cycle. (*Section 5.9*)
- ✓ Record the measured concentration reading (M).
- ✓ Use formula to calculate Dilution Factor:
 - Dilution Factor equals the dilution standard divided by the measured value.
D.F. = (D)/(M) (Typical range 9-13)
- ✓ Store new Dilution Factor in Parameter Settings page (*Section 5.17*)

New Dilution Factor value will be used to calculate the actual concentration during a dilution cycle. Dilution can be initiated manually or automatically once monitor reads value set above Full Scale value.

6.6 Normal Analyzer Operation

Analyzer is ready to start monitoring once all calibration cycles have been completed. To start normal analyzer operation:

- ✓ Select Active Methods in General Settings page. (*Section 5.19*)
- ✓ Setup Sampling Frequency and Calibration Frequency.
- ✓ Start Monitor. The analyzer will now begin monitoring continuously. Automatic calibrations will be performed as programmed. If an error occurs, analyzer will alarm and go into Standby.



7 Maintenance

7.1 Servicing Analyzer

Servicing and maintenance of analyzer depend on many factors including installation environment and sample conditions. Visual checks, monthly and bi-yearly maintenance procedures, internal rinsing, and proper shutdown procedures all promote longer product life.

7.2 Regular Visual Checks:

The μAI 9044 Hydrazine Analyzer should be visually inspected on a regular basis to ensure analyzer accuracy, precision, and efficiency.

- ✓ Check for leaks particularly around sample and drain tube connections.
- ✓ Confirm sample flow by checking sample delivery to the constant head unit and effluent entering drain tubing.
- ✓ Check liquid levels in reagent and standard solution containers.
- ✓ Inspect all tubing and liquid handling components for leaks or deterioration.
- ✓ Check instrument display for malfunctioning indications.

7.3 Monthly

- ✓ Perform visual checks described above.
- ✓ Discard old reagent and standard solutions, clean containers thoroughly, and refill each container with fresh solution.
- ✓ Check condition of sample filter (if fitted), and replace if necessary. Make sure new filter is fitted correctly by following directional arrow located on the filter body.
- ✓ Perform wash, prime, blank, and calibration cycles. (*Section 6*)
- ✓ Put analyzer back into Monitoring mode.

7.4 Quarterly

Rinsing Internal Piping:

Internal piping should be cleaned every six months depending on calibration and sampling intervals. Waltron can supply and ship cleaning solution with reagents. ***The cleaning solution contains sodium hydroxide, which is extremely caustic and must be handled with care. Always wear gloves and eye protection!***

- ✓ Place all reagent tubes, sample tube and DI water tube into the cleaning solution.
- ✓ Put analyzer into a Wash cycle followed by three Reagent Prime cycles.
- ✓ Replace all reagent tubes, sample tube, and DI water tube to correct bottles.
- ✓ Perform all monthly calibrations in *Section 7.3*.

7.5 Bi-Yearly:

Single pump tube must be changed every six months. Monthly tubing replacement is not necessary. Additional bi-yearly maintenance:

- ✓ Service pump. (*Section 7.8*)
- ✓ Perform all monthly calibrations detailed in *Section 7.3*.
- ✓ Clean internal pipe-work with rinse solution (*Section 7.4*).

7.6 Consumable Spares Kit:

Waltron Part Number: **W9040-100**

The μAI9044 Hydrazine Analyzer comes supplied with a consumable spare parts kit. This kit includes all annual replacement components. Replacement details are given in spare parts kit.

7.7 Shut-Down Procedure

The analyzer can be left on without sample flow. Analyzer will automatically stop sampling once it senses missing sample. Reagent lines need to be cleaned and flushed if the analyzer will be out of service for more than a month. See *Section 7.5* for rinsing internal pipe-work.

7 Maintenance

7.8 Changing Pump Tube:

1. Turn analyzer on and perform a wash cycle to flush out system.
2. Turn analyzer off.
3. Open analytical compartment. Unscrew the four knurled head screws holding the pump head in place. Take out pump, open it up and remove silicon pump tubing.
4. Install new tubing using the same high density inner diameter nipple. Connect the tube from the lower side of the pump to the S/L valve, and the tube from the upper side to the bottom nipple of the cylinder 1.

Attention: If the tube is not properly installed, severe system malfunction will occur!

6. Separate pump halves. Hold the pump head as shown, with rollers in 2, 6, and 10 o'clock positions.

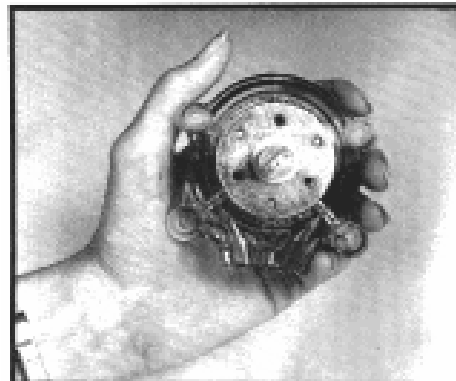

7. Place tubing in the outer port against the two rollers; use thumb to hold tubing in place. Insert tubing key on back of the rotor shaft and push in as far as possible. Tubing is now correctly positioned in the cavity.

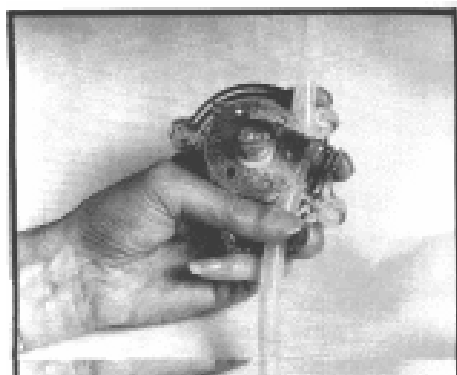

7 Maintenance

8. With tubing key pressed firmly against the rotor, turn counter clockwise while pushing down, until tubing surrounds the rotor.



9. Tubing is now in place. Remove tubing key, position other pump half onto the motor shaft and snap shut. Be careful not to pinch tubing between plastic pump halves.

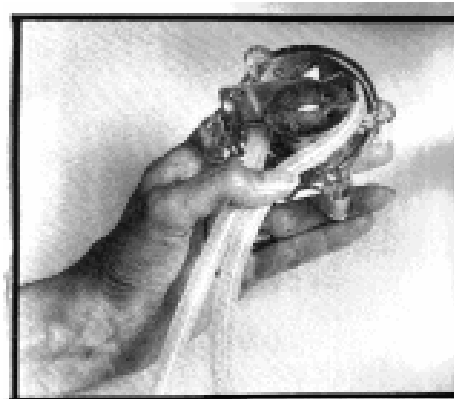

10. Remount pump head and move the roller block until shaft aligns with motor drive.
11. Attach pump using screws.
12. Turn analyzer on.
13. Perform a wash cycle to verify that liquid flows in through inlet and out through waste outlet. If problems occur turn the analyzer off immediately and switch the pump tube connections. Restart and repeat the wash to see if problem is fixed.
14. If analyzer is still not working correctly, check for proper connections correct pump mounting. Check tubing connections for leakage and repeat the pump tube change procedure.

7.9 Unscheduled Servicing:

Monitor Diagnostic Information: The analyzer's diagnostics provide useful problem solving and servicing information. In order to view detail of problems resulting in an Error Alarm, see Main Display Diagnostic Information. Mechanical components involved in liquid handling (pumps, valves, tubing and tubing connections) need to be checked to ensure correct operation.

7 Maintenance

Troubleshooting Table 1

Problem	Possible Causes	Solutions
Calibration error message.	Reagents not properly injecting.	Check that all reagents are injecting during calibration. Each injection should be a solid stream, no sputtering.
Calibration error message.	Standard not drawn in during calibration.	Verify that valve V8 actuates at the beginning of a cal. Check all tubing for holes or kinks. Check for pinched tubing where standard straw mates. Check condition of pump tube.
Calibration error message.	Old or contaminated reagents/standard.	Replace with new. It is recommended that reagents and standards be replaced 1 month after opening.
Calibration error message.	Reagent or standards connected to the wrong tubes.	Double check that all reagents and the standard are connected to the correct corresponding tubes.
Calibration error message.	Incorrect standard value entered on analyzer.	Check that the correct standard concentration is entered in calibration parameters. If this is a dual stream unit, make sure the correct value is entered on each stream's parameters.
Calibration error message.	Calibration differs by 30% or more from previous cal.	The analyzer's default is to give a calibration error message in this case. If current calibration value is good select "calibration parameters", select "last cal od" and press enter to update the latest value.
Calibration error message.	Solenoid valve failure..	Perform solenoids test from operations menu. During the test each row of valves will be actuated from left to right beginning with the reagent valves. Check for good electrical connection on valves that do not actuate before replacing
Calibration error message.	Faulty thermistor or heater if analyzer is so equipped	.View display for "tmp 2". Reading. (9046 uses "tmp 1"). Check that correct temp is entered under heater settings and display is stable within 3-4 degrees.

7 Maintenance

Troubleshooting Table 1 (cont'd)

Problem	Possible Causes	Solutions
Calibration error message.	Organics interference.	Perform multiple washes with 10% Clorox solution. Wait 30 minutes and wash several times with di water and cal again. This may need to be performed multiple times once organics have been established.
Low/high readings.	Calibration not recently performed	Analyzer should be set to auto-cal once per week at the minimum.
Low/high readings.	Poor calibration value.	Repeat calibrations. Refer to calibration error message troubleshooting.
Low/high readings.	. Old or contaminated reagents/standard.	Replace with new. It is recommended that reagents and standards be replaced 1 month after opening.
Low/high readings.	Blank OD value.	When measuring below 10ppb the blank OD value should be manually entered to .0001.
Low/high readings.	Reagents not properly injecting.	Check that all reagents are injecting during analysis. Each injection should be a solid stream, no sputtering.
Low/high readings.	Disconnected/damaged tubing.	Check all tubing for holes/cracks, especially sample tube that runs to constant head block. Check that all tubing is firmly seated on their connections.
Low/high readings.	Low sample flow.	Ensure constant flow throughout the entire cycle. A continual sample stream from the overflow fitting will ensure adequate flow.
Low/high readings.	Blocked waste tube.	Check both waste tube and fitting for particulates or pinched tubing. Ensure waste is flowing freely from the unit.
Low/high readings.	Solenoid valve failure causing sample to not be drawn in.	Run solenoid test to see that all valves are working. Particularly V4 and V5 on dual stream units.
Low/high readings.	Organics interference.	Perform multiple washes with 10% Clorox solution. Wait 30 minutes and wash several times with di water and cal again. This may need to be performed multiple times once organics have been established.

7 Maintenance

Troubleshooting Table 1 (cont'd)

Problem	Possible Causes	Solutions
Missing sample error message	Inadequate/interrupted flow.	A constant flow rate of 150ml/min-500ml/min is recommended. If a steady stream of sample can be seen exiting the overflow fitting then flow is adequate.
Missing sample error message	Dirty float switch.	Remove float switch from constant head block. Clean float and inside of block with damp cloth.
Leakage alarm message	Wet leakage alarm sensor.	Check for liquids in the bottom of the cabinet and identify cause. Dry end of leakage alarm sensor and message should revert to "leakage off". Resume operation.
Air in cell alarm message	Empty calibration standard or DI water bottle.	Check level of bottles and fill.
Air in cell alarm message	Air is being drawn into the system during analysis.	Check all tubing for pinholes and that they are properly connected to their respective valves. Check pump tube. Ensure adequate sample flow.
Reagents not injecting.	Reagent valves not actuating.	. Perform solenoid test. Replace valve if not actuating
Reagents not injecting.	. Cracked reagent tubing	Replace reagent tubing from reagent valves to solenoid bottles. Also replace tubing that mate with reagent straws.
Reagents not injecting.	. Clogged reagent tubing/straws/valves.	Replace reagent tubing/straws. Disassemble valve and clean membrane. (Older style circular valves cannot be disassembled and need to be replaced).
Reagents not injecting.	Vacuum is not being formed within C1 injection chamber	Perform solenoid test to ensure all valves are actuating. Check all tubing and pump tube for holes or improper seals allowing loss of vacuum. Ensure pump operates both clockwise and counterclockwise.
Reagents sputtering during injection.	. Damaged reagent tubing.	Check entire length of tubings from reagent valves to reagent bottles for cracks, pinholes, or improperly sealed mating tubings.
Reagents sputtering during injection.	Valve/reagent lines partially clogged with precipitates	Perform multiple prime operations to pass 5-10% sodium hydroxide through the reagent valves/tubing. Then flush with DI water



7 Maintenance

Troubleshooting Table 1 (cont'd)

Problem	Possible Causes	Solutions
Tubing popping off valves.	Kinked tubing/blockage.	Check all tubing for kinks where it curves. Ensure waste is flowing freely. Inspect for blockage within tubes and glass flowcell.
Tubing popping off valves.	. Solenoid valve failure.	Run solenoid test.
Tubing popping off valves.	Worn/improperly installed pump tube causing excess pressure	Replace pump tube
Unit is always running in “dilution” mode.	Sample concentration exceeds full scale of analyzer.	Check that the “full scale concentration” value has not been set lower than the sample concentration. The user should set this value equal to or less than the stated full range of the analyzer.
Unit is always running in “dilution” mode.	Excessive air bubbles being introduced.	Check all tubing for cracks/holes. Ensure adequate sample flow throughout the entire cycle.
Unit is using an excessive amount of DI water.	. Calibration cycle is being run too frequently.	Adjust calibration frequency settings. Analyzer will use DI during calibrations; grab samples, primes, blanks, washes, and dilutions.
Unit is using an excessive amount of DI water.	Unit is running in dilution mode	Refer to dilution troubleshooting above.
Unit is using an excessive amount of DI water.	Valve VC4 is failing.	Run solenoid test.
No 4-20 mA output.	Loose connection on current output terminal (P8 on RFIO board).	Tighten screws on P8. Ensure it is not crimping on wire’s insulation.
Incorrect 4-20 mA output.	Full scale setting differs from expected 4-20 correlation.	Check “full scale conc.” field for 20mA correlation. (This will be under “full scale D.A.C.” on newer units).



8 Specifications

General description	Data
Sensor classification	Colorimetric dual beam with silicon detector.
Application	Demineralised, boiler, potable, surface, and waste water
General specifications	Data
Power requirements	12 Vcc
Power Supply	110-120V or 220-240V, 50/60 Hz, 100 VA
Humidity	Up to 90% not condensable
Ambient Temperature range	10 – 40° C analyzer (50-104°F)
Unit dimensions	800 mm x 420 mm x 275 mm or (31.5” x 16.54” x 10.83”) (h x w x d)
Atmospheric pressure range	No limits
Effect of electromagnetic fields	EMC tested according CE compliance
Tolerance to electrostatic discharges	EMC tested according CE compliance
PC specification – O/S	PC 104 industrial standard under MS-DOS O.S.
Positioning and installation details	Wall mounted analyser. To be installed approximately 100 cm from ground. Maximum distance from sampling point is 4 m.
LFA reactor volume	10 ml
Materials in contact with sample	Glass. Silicone, Plexiglas, stainless steel AISI 316
CE compliance	YES
Year 2000 compliance	YES
General hazards	Only chemical, for details see specific chemistries
Sample conditioning requirements	Filter particles between 10 and 60 microns depending on the matrix.
Sample delivery oper. ranges	Data
Temperature range	5° - 55 ° C (41-131° F)
Flow	Min: 150 – 200 ml/min (150 – 200 cc/min)
Turbidity	Not applicable; sample blank correction
Colour	Not applicable; sample blank correction
pH	3 – 12
Pressure	5-30 psi
Signal outputs	Data
4 – 20 mA – Voltage 0 – 5	4 – 20 mA or 0-5 V (Galvanic isolator module also available.)
Printer options	Optional, serial output RS232 or 485
Radio or modem links	Available as option
Grounding details	Not applicable, 12 Vcc power device
Serial I/O for signals	Serial data output RS232 or 485 available as option
Commissioning	Data
Manufactures’ set-up details / pre-installation guide	Setup details supplied on order confirmation to allow preparing of installation site, also included in operating manual delivered with the analyser.
Factory final test certification	Delivered with the analyzer
Description of sensor technology	Available, enclosed with the instruction manual
Operating sequence	Available, enclosed with the instruction manual
Calibration method	Available, enclosed with the instruction manual
Operational calibration	Data
Frequency / intervals	Recommended: 7 days
Single / multi point	Multipoint: 0 and range maximum
Matrix corrections	Yes, sample blank correction
Manual / automatic	Both



9 Spare Part Listing

*Spare Parts may be ordered by contacting Waltron at:
1-800-242-7353*

Spare Parts may also be ordered from the Waltron website at www.waltron.net or www.waltron.org

Spare Part	Description	Spare Part	Description
W9040-002A	Tubing, Silicone, 0.045 X 0.035, (CS)	W9040-030	STA-UMAC Board
W9040-002B	Tubing, Silicone, 0.081 X 0.035, (CS)	W9040-031	MPIO Board
W9040-003	Tubing, Teflon, 1 X 1.5 mm. Reagents	W9040-075	CPU Board, PC 104
W9040-004	Tubing, Silicone, 2 X 4 mm. (CS)	W9040-033	RFIO Board
W9040-004A	Tubing, Silicone, 1.8 X 4 mm. (CS)	W9040-067	STA-MMAC Board
W9040-005	Reaction Cylinder Block	W9040-036	STA-MONT-02 Board
W9040-006	Pump Motor	W9040-071	LM 35 Temperature Sensor
W9040-007	Pump Head	W9040-037	Sample or Reference Sensor Reagent Cylinder Top (Need to specify unit parameter)
W9040-008	Silicon Pump Tube,	W9040-066	Reagent, Straw (CS)
W9040-009	Reagent Injection Valve (round)	W9040-039	Display (w/o membrane)
W9040-009A	Reagent Injection Valve (square)	W9040-044A	Tubing, Small Reagent Straw Bushing
W9040-010	2 Way Valve, (N.O.)	W9040-061	Tubing, Large Reagent Straw Bushing
W9040-011	3 Way Valve	W9040-062	T-Connector
W9040-012	2 Way Valve, (N.C.)	W9040-063	L-Connector
W9040-013	Flow Cell, 50 mm	W9040-064	O-Ring for Reagent Valve
W9040-014	Flow Cell, 15 mm	W9040-065	60 Micron Filter
W9040-015	Flow Cell, 5 mm	W0217-463	Consumables Kit, W9040
	Emitter, 470NM	W9040-100	Color Reagent, Hydrazine, 1L
W8240-114	Float Switch	W1234-074	9040 Series Washing Solution 1L
W9040-026	Colorimeter Pre-Amp Board	W1234-556	Heating Bath Assembly, Complete
W9040-027	Flowcell, Holder	W9040-076	
W9040-028	Flowcell, Heating Block		

APPENDIX: Panel Mount (Optional) Schematics

