

# Waltron AQUALERT® Division

---

## Water Chemistry Measurement & Control



## Quantichem® 9031C Sodium Analyzer Instruction Manual

Revision 2.14



9031C

## **WALTRON CUSTOMER COMMITMENT**

This instruction manual is a technical guide to aid the customer in the set-up and maintenance of their new Waltron measuring system. Waltron provides continuous product improvement and reserves the right to make any modifications to the information contained herein without notice.

*Copyright © Waltron Bull & Roberts, LLC, 2014  
All Rights Reserved*

Technical questions concerning this product should be addressed to:

## **Waltron Technical Service Department**

Whitehouse, New Jersey

**Phone:** (800)-242-7353 **Fax:** (908)-534-5546

[www.waltron.net](http://www.waltron.net)

*Please be ready to provide the following information:*

- Date analyzer was purchased.
- Analyzer model and serial number.
- Recent maintenance history.
- Calibration slope values and detailed description of problem.

Waltron's technical expertise and extensive experience provides personalized solutions to the water quality industry. It is Waltron's commitment to provide the customer with timely and accurate technical service and support.

Waltron fully expects the customer to be satisfied with the quality, performance, and cost of this product. If there are any questions or concerns regarding this product, please feel free to contact Waltron at 1-(800)-242-7353.

Thank you for choosing Waltron!

---

*Please note Waltron mailing and UPS shipping addresses:*

***DIRECT ALL CORRESPONDENCE TO:***

Waltron Bull & Roberts, LLC  
P.O. Box 70, 50 Tannery Rd.  
Whitehouse, NJ 08888

***DIRECT ALL UPS SHIPMENTS TO:***

Waltron Bull & Roberts, LLC  
50 Tannery Rd.  
Somerville, NJ 08876

***Safety:***

---

Please observe proper safety and handling precautions when installing, operating, maintaining, and servicing this product. The following should be noted and adhered to:

- √ Read and understand manual before working with analyzer.
- √ Pay special attention to warning labels on enclosures, containers, packages and chemicals.
- √ Only qualified personnel should be involved in the installation, operation, and servicing of the analyzer.
- √ Follow safety precautions when operating analyzer in conditions of high pressure and/or temperature.
- √ Keep analyzer chemicals away from heat and extreme temperatures. Reagent powders must be kept dry.
- √ Follow all regulations and warning labels when disposing of chemicals. Do not mix chemicals.

*To obtain analyzer safety information or **Material Safety Data Sheets (MSDS)**, please contact Waltron or logon to [www.waltron.net](http://www.waltron.net).*



## ***Warranty Agreement***

---

If, within one year from the date of shipment, the customer experiences any equipment defects or is not satisfied with the analyzer manufacturing, Waltron will repair, or at its option, replace any defective part(s) free of charge. This warranty requires that the defective part(s) be returned to Waltron in Whitehouse, NJ with shipping charges prepaid.

At Waltron discretion, a Technical Service Specialist may be sent out to repair or replace the defective part(s) on location. Traveling time and expenses of the Technical Service Specialist is at the customer's expense.

Equipment sent to Waltron must be appropriately packaged and the following information must be provided prior to returning to Waltron:

- √ The Return Authorization (RA) number assigned to the customer by the Waltron Technical Service Department.
- √ Customer name, address and department.
- √ Name and telephone number of the individual responsible for returning items for repair.
- √ Brief problem description.

### **Ship to Waltron Service Center:**

**-Via Mail:**

Waltron Bull & Roberts, LLC  
P.O. Box 70, 50 Tannery Rd.  
Whitehouse, NJ 08888

**-Via UPS/FED-EX/Motor Carrier:**

Waltron Bull & Roberts, LLC  
50 Tannery Rd.  
Somerville, NJ 08876



## ***Checklist of Materials***

---

In order to ensure customer satisfaction, Waltron does its best to provide adequate and timely packaging and shipping services. Please perform the following after receiving a shipment:

- √ Inspect all shipping containers upon receipt and record any visible damage. If there are any outward signs of damage, please retain all containers and packages for inspection by carrier. Please retain all packing material so that it can be used for future moving and shipping needs.
  
- √ Check all items received against those on the packing list. Chemicals are usually shipped in a separate package and will be itemized accordingly.
  
- √ Verify that the number of packages received agrees with the packing list and shipping papers.
  
- √ Notify both Waltron and the carrier if any problems occur.

### ***Important Notice***

- √ All monitors are inspected and tested prior to shipment.
- √ In normal use, the unit should require only minor maintenance and should operate correctly and without fault over a long period of time.
- √ Please note that if electronic components need to be replaced, it may be necessary to adjust and/or calibrate the monitor.
- √ Failure to carry out correct maintenance procedures may result in inaccurate monitor reading.

**Table of Contents**

---

<b>1</b>	<b>INTRODUCTION .....</b>	<b>8</b>
1.1	GENERAL.....	8
1.2	MAIN FEATURES.....	8
1.3	SYSTEM DESCRIPTION & ARCHITECTURE .....	9
1.3.1	WET SECTION UNIT .....	10
1.3.2	PRE-AMPLIFIER AND JUNCTION BOX.....	10
1.3.3	TRANSMITTER UNIT.....	10
<b>2</b>	<b>INSTALLATION.....</b>	<b>11</b>
2.1	MOUNTING OF WET SECTION UNIT.....	11
2.1.1	LOCATION AND LAYOUT .....	11
2.1.2	MOUNTING OF TRANSMITTER UNIT .....	12
2.2	SAMPLE REQUIREMENTS.....	13
2.3	EXTERNAL PIPING CONNECTIONS .....	14
2.4	ELECTRODE INSTALLATION .....	14
2.4.1	PROBE CONNECTIONS.....	14
2.4.2	AUTOMATIC KCL REFILL SYSTEM (OPTIONAL) .....	15
2.4.3	PROBE INSTALLATION PROCEDURES.....	16
2.5	ELECTRICAL CONNECTIONS.....	17
2.5.1	WET SECTION UNIT .....	17
2.5.2	PRE-AMP UNIT.....	18
2.5.3	JUNCTION BOX.....	20
2.5.4	TRANSMITTER UNIT.....	21
2.5.5	AC POWER TERMINAL BOX (OPTIONAL) .....	23
2.5.6	CE POWER CONNECTIONS (OPTIONAL) .....	23
2.5.7	WIRING TO TRANSMITTER.....	24
<b>3</b>	<b>OPERATING THE ANALYZER .....</b>	<b>28</b>
3.1	ANALYZER OPERATION .....	28
3.2	ALARMS.....	29
3.3	GETTING STARTED .....	30
3.4	POWER UP SEQUENCE.....	30
3.5	KEY-BOARD FUNCTIONS.....	31
3.6	MAIN MENU - ANALYZER MODES .....	32
3.6.1	MEASUREMENT.....	32
3.6.2	CONFIGURATION.....	32
3.6.3	MANUAL CALIBRATION .....	36
3.6.4	FAIL SAFE.....	38
3.6.5	DIAGNOSTICS.....	39
3.6.6	DISPATCH MODE .....	44
3.7	CALIBRATION PROCEDURE.....	46
3.7.1	SINGLE POINT CALIBRATION .....	46
3.7.2	TWO POINT CALIBRATION .....	47
3.7.3	CALIBRATION FAILURE .....	48
<b>4</b>	<b>TROUBLESHOOTING – CALIBRATION FAIL.....</b>	<b>49</b>
<b>5</b>	<b>MAINTENANCE.....</b>	<b>49</b>



- 5.1 BUFFER SOLUTION(S)..... 49
- 5.2 STANDARD SOLUTIONS..... 51
- 5.3 ETCHING SOLUTION ..... 52
- 5.4 REFERENCE ELECTRODE FILL SOLUTION (For Use with N3010-171A)  
53
- 5.5 SCHEDULED SERVICING ..... 53
  - 5.5.1 WEEKLY..... 53
  - 5.5.2 MONTHLY ..... 53
- 5.6 SHUT-DOWN PROCEDURE (Prolonged Shut-Down, 1+ months)..... 54
  - 5.6.1 STORAGE OF ELECTRODES ..... 55
- 5.7 pH EFFECTS ..... 55
- 6 SPARE PARTS ..... 56**
- 7 TROUBLE-SHOOTING..... 57**
- 8 SPECIFICATIONS ..... 60**
- 9 APPENDIX 9031C ..... 61**
- 10 APPENDIX Panel Mount..... 62**
- 11 APPENDIX Instructions for Crimping Terminals..... 63**
  - 11.1 Crimping Terminal onto Wire Ends ..... 63
  - 11.2 Attachment of Terminated Wires to the Analog Board ..... 65



## **1 INTRODUCTION**

### **1.1 GENERAL**

The Waltron Quantichem<sup>®</sup> 9031C Sodium Analyzer is a microcontroller-based unit used for online measurement of sodium content in various water chemistry/treatment applications. Sampling points for power generation include mixed bed outlets, extraction pump discharge, boiler feed, boiler drum and steam. The measurement range of the 9031C analyzer spans from 0.01ppb to 10ppm.

### **1.2 MAIN FEATURES**

Features of Quantichem<sup>®</sup> 9031C Sodium Analyzer unit include:

1. Measurement of sodium concentration
  - Wide range analysis - 0.01ppb to 10ppm. Concentration and temperature are displayed continuously and analyzer adjusts automatically to user specified ranges.
  - Automatic temperature compensation
  - Protection from “Hot Sample”
2. Calibration
  - Single & two point calibration
  - Low reagent and standard consumption
  - Internal diagnostics used to show probe status
3. User Interface
  - 128x64 pixel graphics LCD with backlight
  - Large easy to read graphic display
  - Tactile membrane keypad (4 keys) on front panel
  - Lower 2 lines of display for user interface messages. Menu driven software interface for various operations including diagnostics, configurations, calibrations, and dispatch modes.
4. Communication Interface via RS-232 & RS-485 using MODBUS RTU protocol
5. Analyzer Configuration :
  - User configurable settings for recorder outputs and alarm set points
  - Factory defaults can easily be reloaded to override user setting
6. Automatically stores last 10 calibration and alarm logs.
7. Complete analyzer diagnostics - individual transmitter module can be tested independently
8. Dispatch mode facility
9. 3 Relay outputs for High, Low and General Alarm
10. Two 4-20mA isolated current outputs
14. Wide range of input power supply 90VAC to 250VAC



### 1.3 SYSTEM DESCRIPTION & ARCHITECTURE

The 9031C Sodium analyzer system is comprised of the following:

1. Wet-Section (Sensor Unit)
  - a. Hydraulic panel consisting of constant head, flowcell, tubing, thermistor and solenoid valve
  - b. Sodium and reference electrodes
  - c. Reagent container
  - d. Separate sodium standard solution containers (CAL1 and CAL2)
2. Pre-Amp and Junction Box units
3. Transmitter (electronics) unit



**9031C  
Transmitter  
Section**

**9031C Wet  
Section**



**Figure 1.** Overall system architecture.

### 1.3.1 WET SECTION UNIT

The 9031C Sodium system is capable of monitoring sodium concentrations in sample feed. The solenoid valve is used to select between analyzing the sample, and accessing calibration standard 1 (CAL1)/calibration standard 2 (CAL2) during calibration.

In normal mode, the feed water flows from the inlet into the heat exchanger through the solenoid valves and into the flowcell where it comes into contact with the sodium and reference electrodes. The electrodes transmit a voltage proportional to the sodium content in the feed water. This output is then measured by the electrical system and converted into a ppb/ppm measurement. An internal thermistor (housed in flowcell) is used to monitor the sample temperature for temperature compensation. If the sample temperature exceeds 131°F, sample automatically gets diverted to drain and the system displays “HOT”.

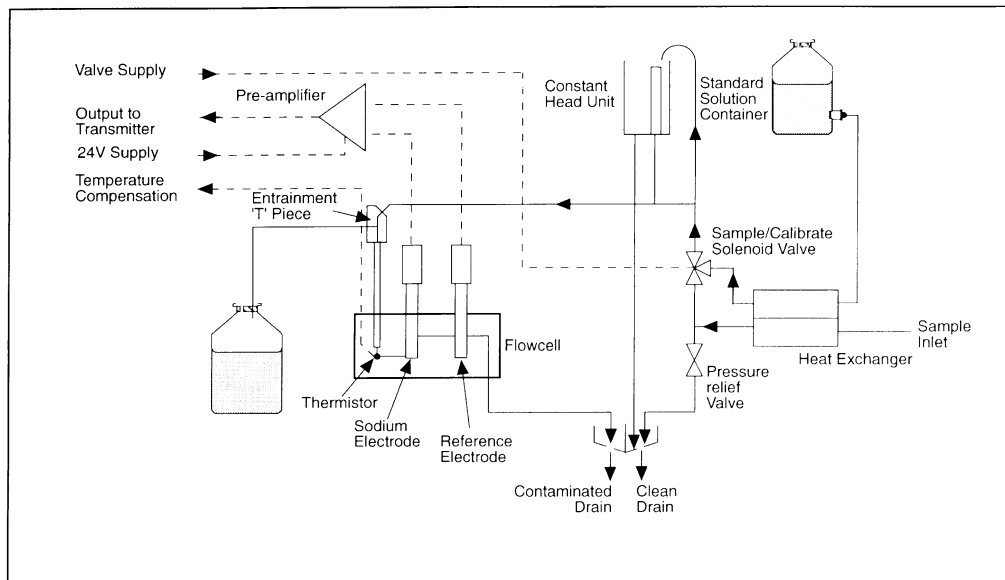

Figure 2. Sample flow during normal operation.

### 1.3.2 PRE-AMPLIFIER AND JUNCTION BOX

The 9031C Sodium analyzer requires a pre-amplifier unit which amplifies and converts the voltage output from the electrodes into proportionate current. Thermistor output is also fed to transmitter unit via pre-amp section. The junction box houses the wiring connection terminals from electrodes and sends the signal to pre-amplifier unit. The terminal junctions at the junction box allows for quick and easy change-out of electrodes.

### 1.3.3 TRANSMITTER UNIT

The transmitter unit interprets electrode response and temperature output from the pre-amp and displays the corresponding sodium concentration (in ppb/ppm) and temperature. The transmitter unit controls all the operations of the analyzer system. The display is a graphics LCD with backlight.

## 2 INSTALLATION

### 2.1 MOUNTING OF WET SECTION UNIT

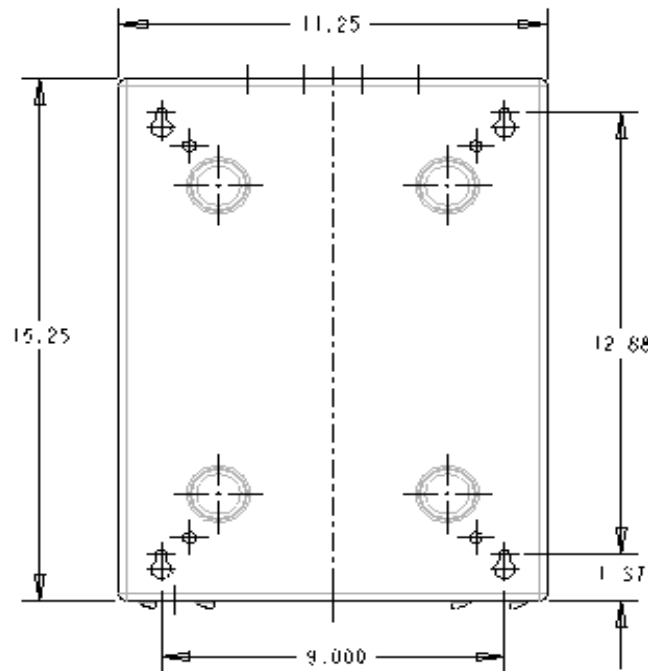

**Figure 3.** Dimensions to mount the Wet Section. (All dimensions in inches)

#### 2.1.1 LOCATION AND LAYOUT

Mount the analyzer in a clean, vibration-free area avoiding direct radiant heat, sunlight and drafts. Avoid areas containing chlorinating equipment. The 9031C Sodium analyzer default design is comprised of two separate sections (transmitter and wet section). The sensor unit can be mounted separately as long as it is no more than 330 feet (100meters) from the transmitter unit.

### 2.1.2 MOUNTING OF TRANSMITTER UNIT

The transmitter unit controls the operations of the analyzer. Power supply, CPU card, Analog card and input power terminal junction are housed in the transmitter enclosure. Transmitter unit is a NEMA 4X rated enclosure with cable glands for wiring. Size and layout of transmitter is shown below.

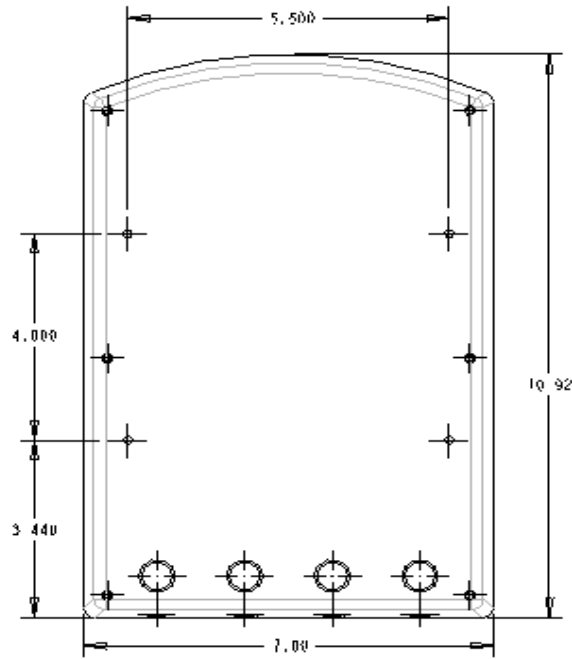

**Figure 4.** Dimensions of the transmitter unit. (All dimensions in inches)

For ease of mounting, the transmitter is attached to a sheet metal mounting bracket. The entire piece (transmitter on mounting bracket) can then be wall-mounted. Size and layout of mounting bracket is shown below.

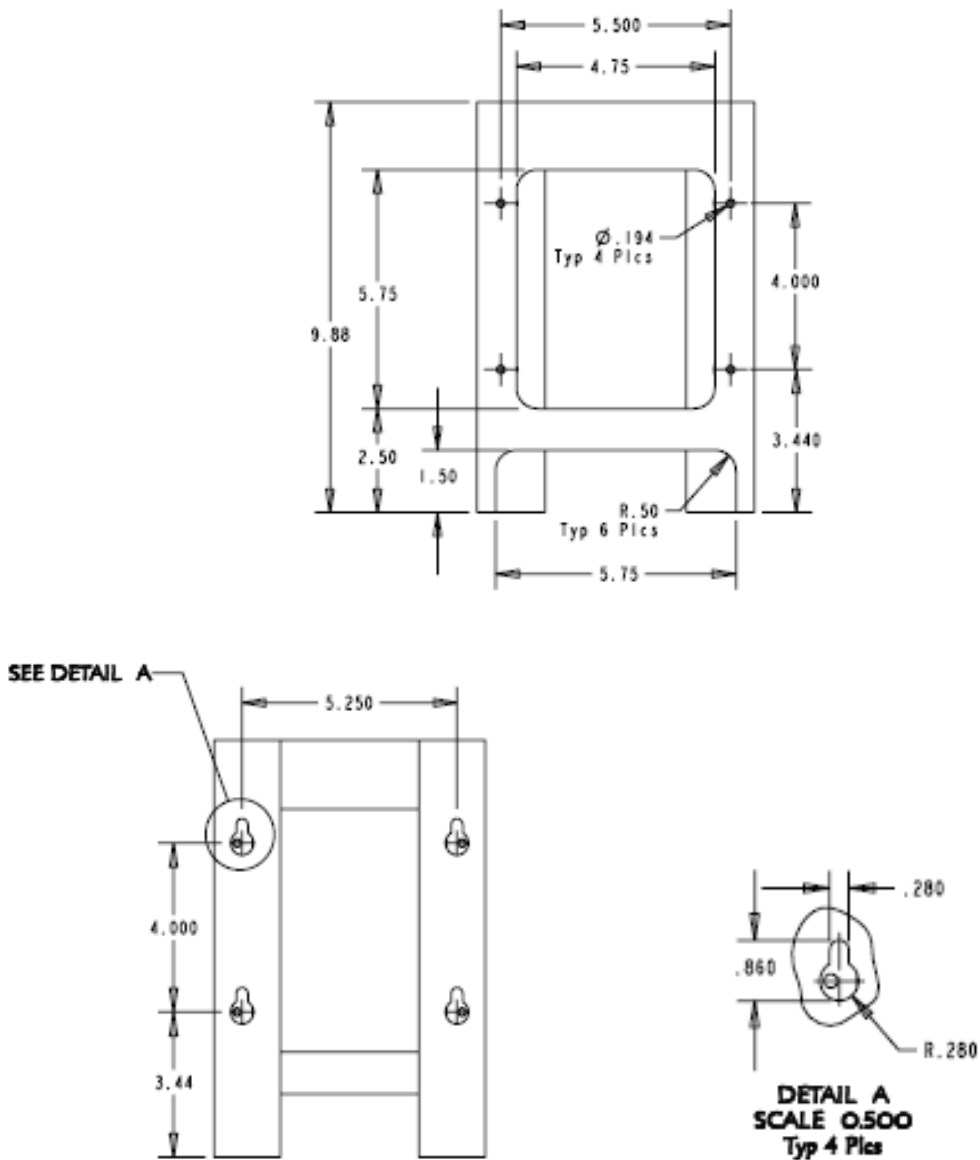
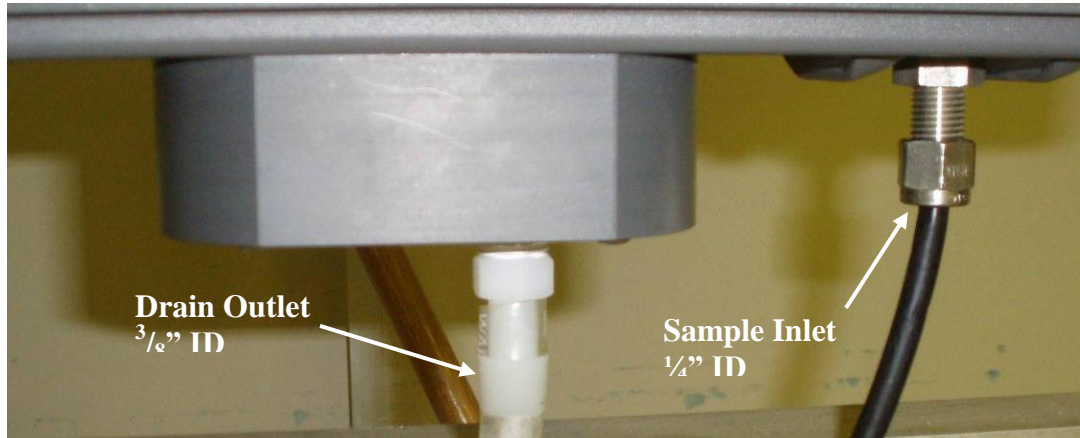

Figure 5. Dimensions for the transmitter mounting bracket.

## 2.2 SAMPLE REQUIREMENTS

The maximum sample pressures and temperatures specified in the SPECIFICATION section should not be exceeded. The sample should be introduced to the system at a temperature and pressure suitable for measurement. If necessary, customer may choose to use sample cooling and pressure reducing equipment. **It is highly recommended that a flow meter is installed to the sample inlet stream to ensure that the sample flow rate is within the specified range.** When pressure reducing equipment is being used, a pressure relief valve should be installed between the sample point and sample inlet to ensure maximum safety.

## 2.3 EXTERNAL PIPING CONNECTIONS



**Figure 6.** The bottom of the wet section case, with the sample inlet and drain connections shown.

## 2.4 ELECTRODE INSTALLATION

### 2.4.1 PROBE CONNECTIONS

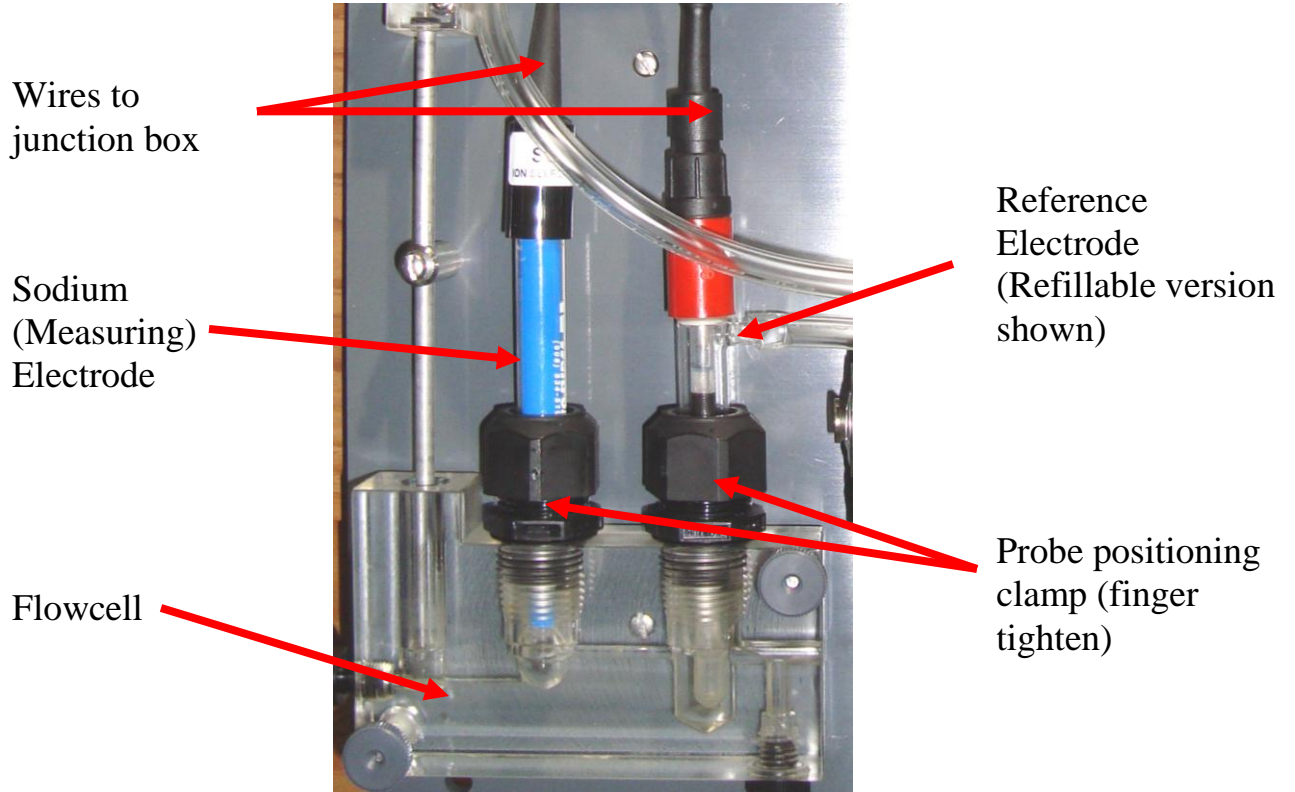

**Figure 7.** Installation of the measuring and reference electrodes.

**2.4.2 AUTOMATIC KCL REFILL SYSTEM (OPTIONAL)**

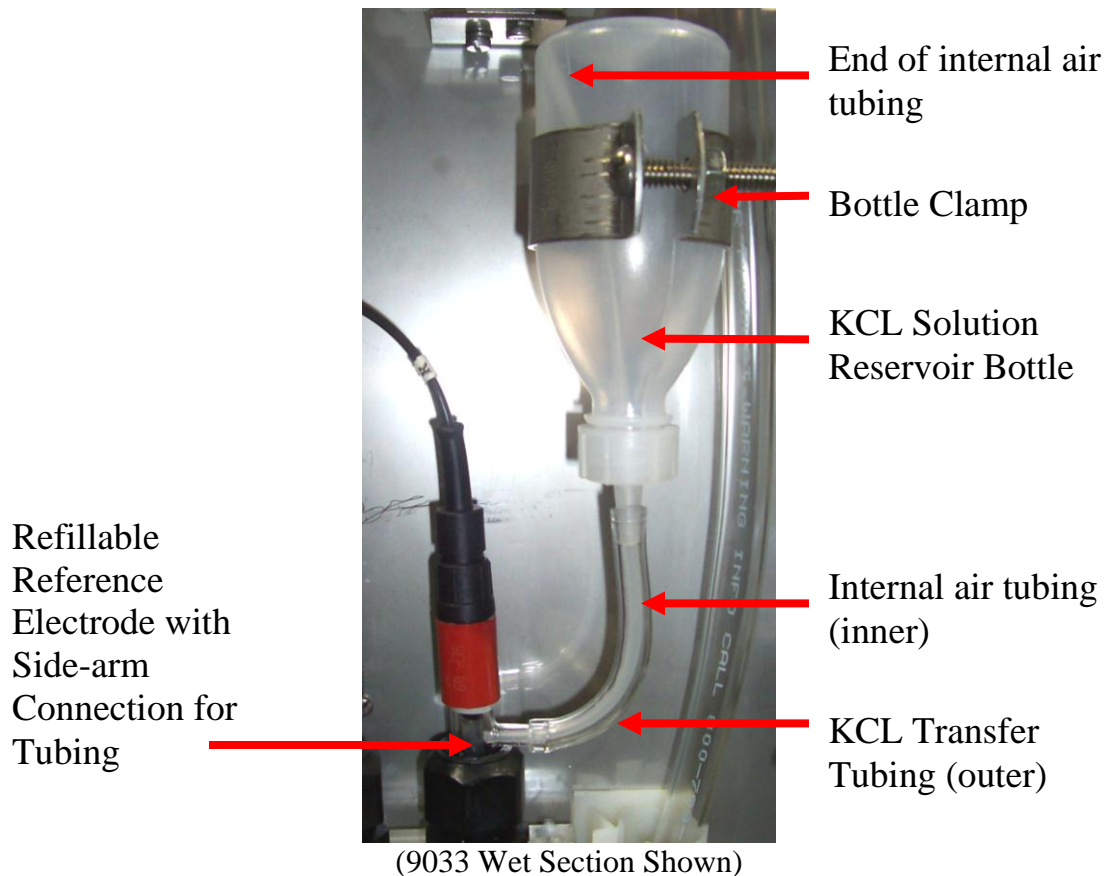

Directions for installing and using the KCl refill system:

1. Feed inner (smaller diameter) tubing through outer (larger diameter) tubing.
2. Feed inner tubing through the side-arm of the reference electrode and connect the outer tubing over the side-arm.
3. Clip nozzle of KCl bottle, making sure the hole is large enough for inner tubing to pass through and that KCl solution can flow freely around it.
4. Insert inner tubing through nozzle of bottle and connect outer tubing over the nozzle of bottle. Make sure the inner tubing reaches the top of the bottle while the other end remains inside the reference electrode.
5. Install KCl bottle into the bottle clamp and finger-tighten wing nut to hold the bottle in place.
6. Poke a small hole in the top of the bottle so KCl flows freely and vacuum does not form.
7. Rinse off any spilled KCl with DI water before installing probe in the flowcell. (KCl will interfere with sample reading if it gets in the flowcell.)

### 2.4.3 PROBE INSTALLATION PROCEDURES

1. Remove the protectors from the tip of each electrode
2. Connect electrodes to junction box.
3. Use fingers to rotate the probe positioning clamp counterclockwise to loosen. Carefully insert the electrode through the clamp and into the flowcell. Electrodes may have to be inserted at an angle.
4. For reference electrode - insert the electrode so that the tip of the electrode is 5mm into the sample. Correct placement within the flow cell is important. Refer to figure below.
5. For measuring electrode – insert the electrode so that the tip is just off the bottom of the flowcell. Refer to figure below.

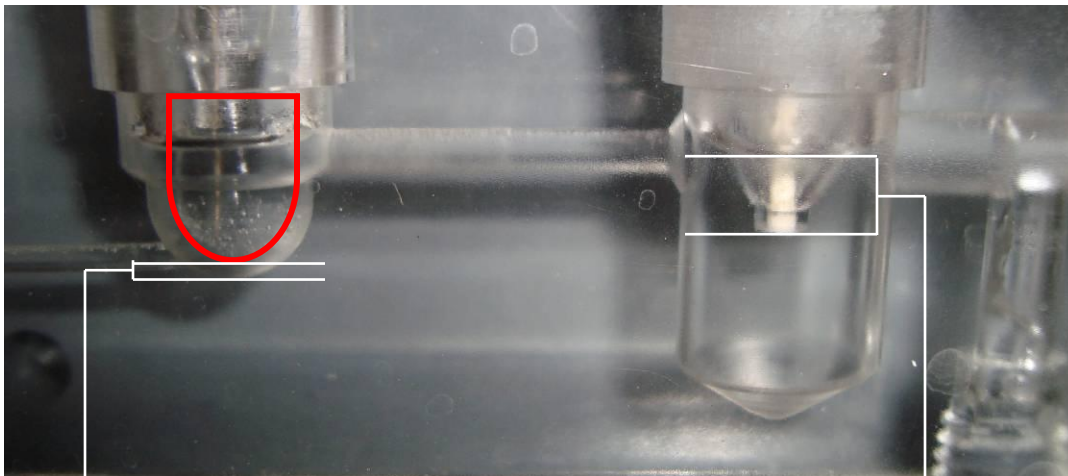

Tip of measuring  
electrode  
positioned just off  
bottom of flowcell

Tip of reference  
electrode  
positioned 5mm  
into sample

**Figure 8.** Correct probe tip positioning in flowcell.



## 2.5 ELECTRICAL CONNECTIONS

### 2.5.1 WET SECTION UNIT

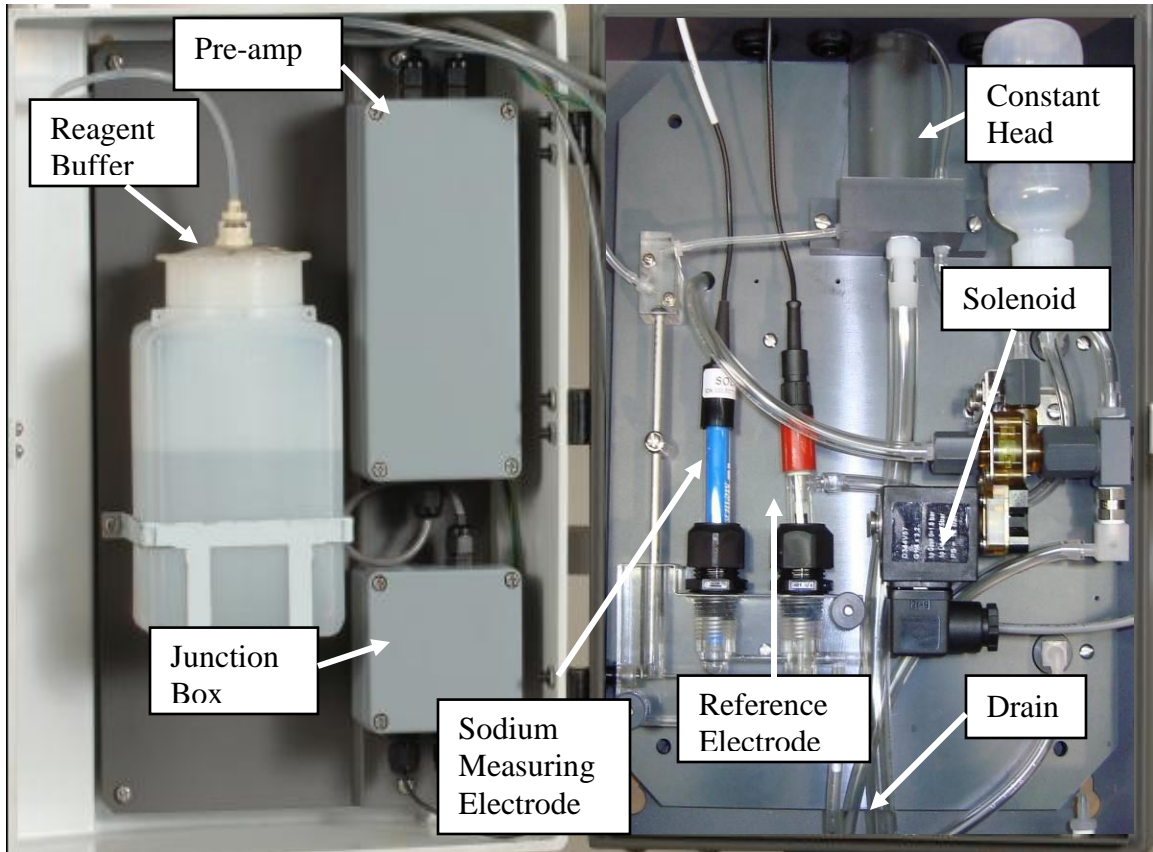

**Figure 9.** The wet section layout and connections.

2.5.2 PRE-AMP UNIT

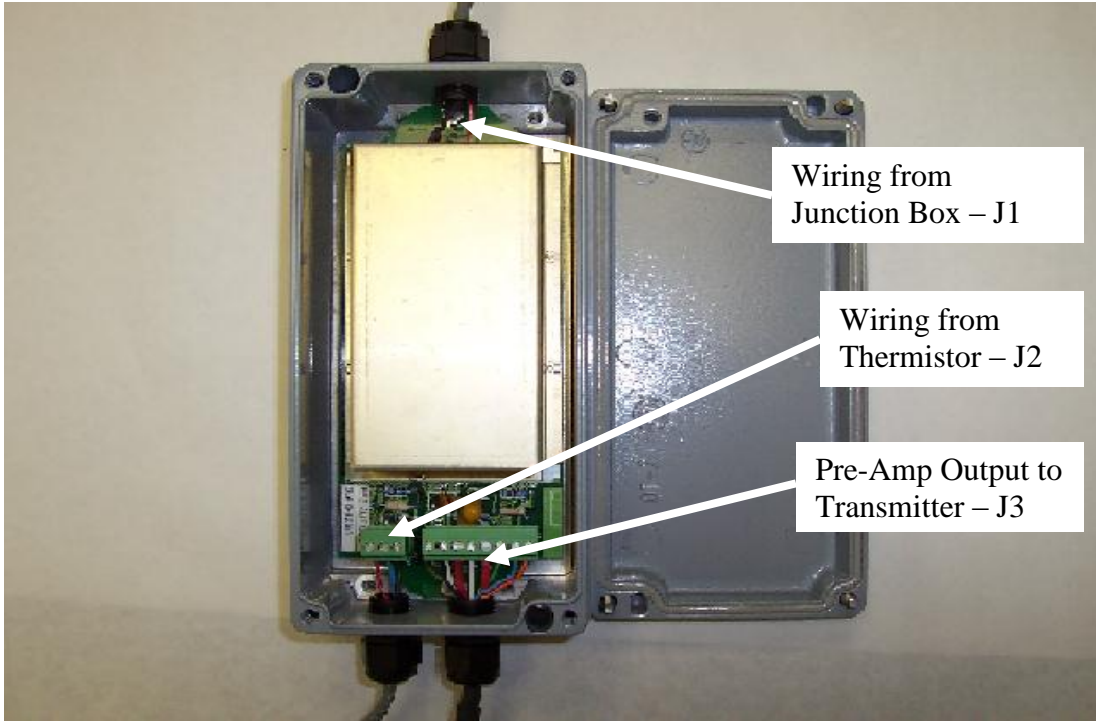

The pre-amplifier unit has 3 connection terminals (J1, J2, J3) shown below:



**Figure 10.** Pre-amplifier layout. Pin 1 of all the connectors is shown in black.



The following cables/connections are used in pre-amp system:

1. Multicore cable (8-Core) for interfacing the transmitter unit with pre-amp at J3.

- Pin 1 (Black Wire)
- Pin 2 (White/Black Wire)
- Pin 3 (Red Wire)
- Pin 4 (White Wire)
- Pin 5 (Red/Black Wire)
- Pin 6 (Green Wire)
- Pin 7 (Blue Wire)
- Pin 8 (Orange Wire)
- Pin 4 (Shield – Optional)

2. Multicore cable (2-Core PVC Shielded Twisted) for interfacing the sodium electrodes (from Junction Box) with pre-amp at J1.

- Red Wire : From Reference Electrode to Pin 1 of J1
- Black Wire : From +ve of Na electrode to Pin 3 of J1
- Black Heat Shrink (Shield) : From -ve of Na electrode to Pin 2 or 4 of J1

3. Multicore cable (2-Core PVC Shielded Twisted) for interfacing the thermistor with pre-amp at J2.

- Blue Wire : From +ve Thermistor to Pin 1 of J2
- Red Wire : From -ve Thermistor to Pin 2 of J2
- Black Heat Shrink (Shield) : From shield to Pin 3 of J2

### 2.5.3 JUNCTION BOX

The measuring and reference electrodes are wired through the junction box enclosure. Remove the lid of the enclosure and pass the leads for both electrodes through the cable glands. Connect the leads to the terminal block as shown in Figure 9.

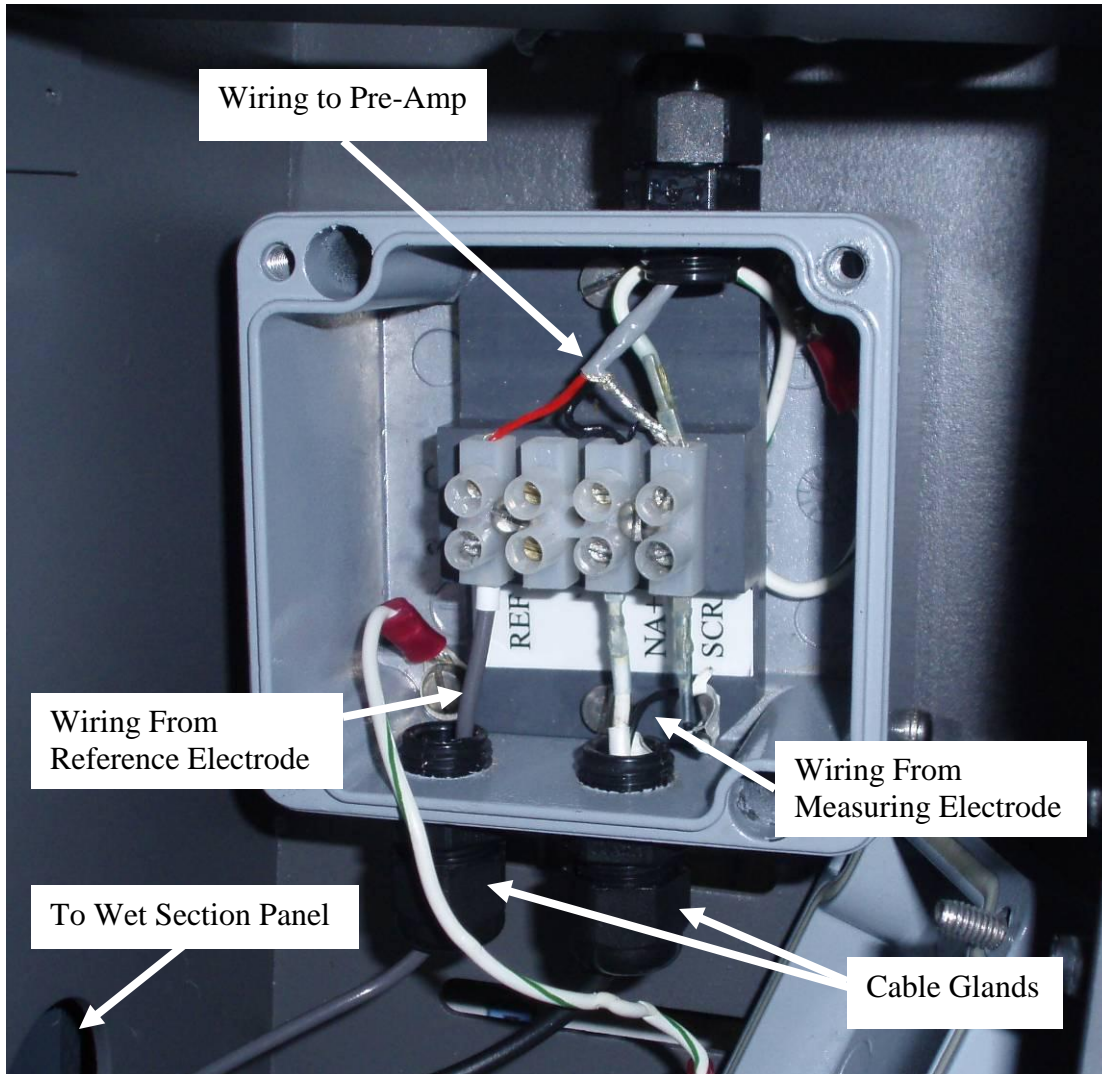

**Figure 11.** Sensor wiring to the junction box.

### 2.5.4 TRANSMITTER UNIT

Proceed as follows to gain access when making the necessary connections:

Remove the six screws securing the top cover of the transmitter unit. Pass appropriate cables thru the cable glands for the following connections:

- Power Supply
- Solenoid and Alarms
- Pre-amp Input (sensor and thermistor wiring)
- 4-20mA Current Output and Communication Interface

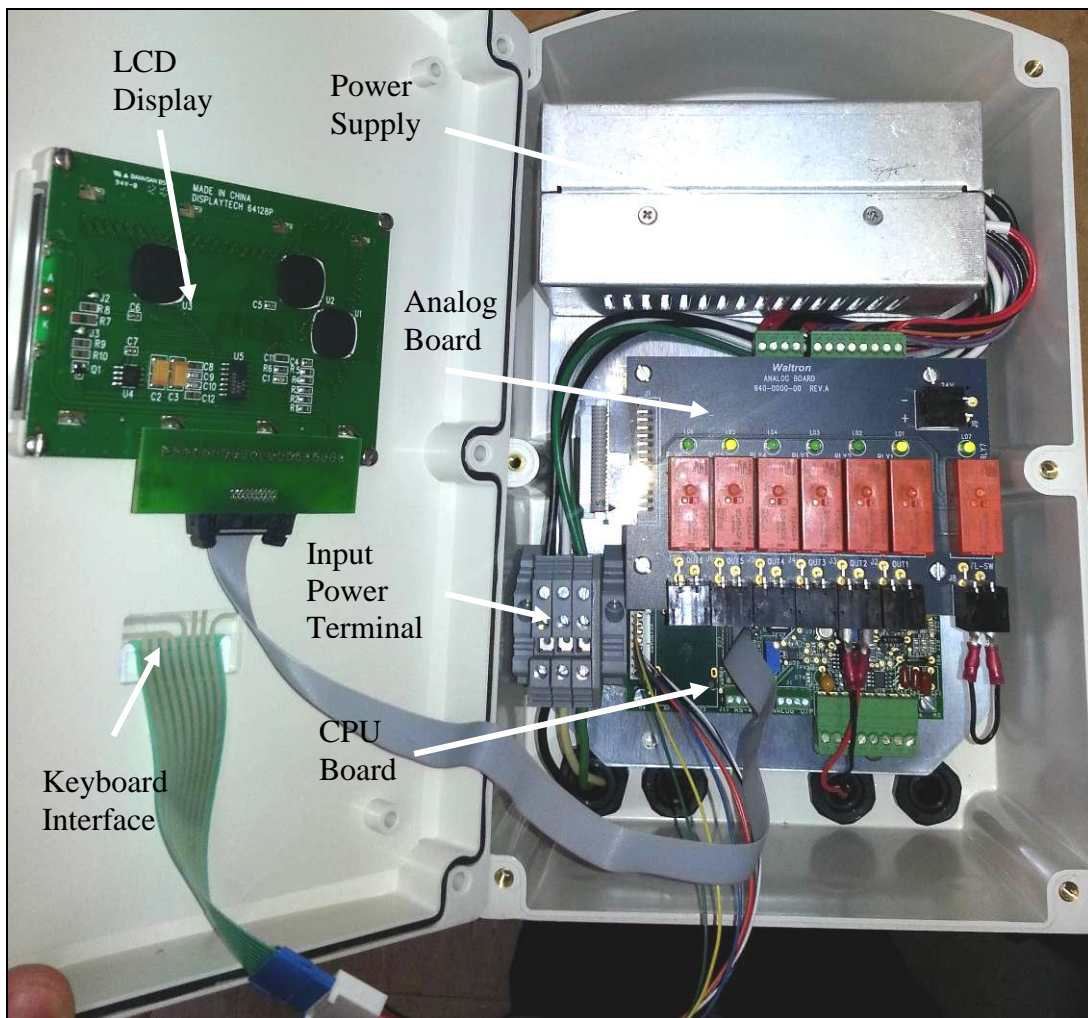

**Figure 12.** The layout and components of the transmitter case.

**Note.** Before connecting the analyzer to the main power supply check that there is correct voltage at the mains.

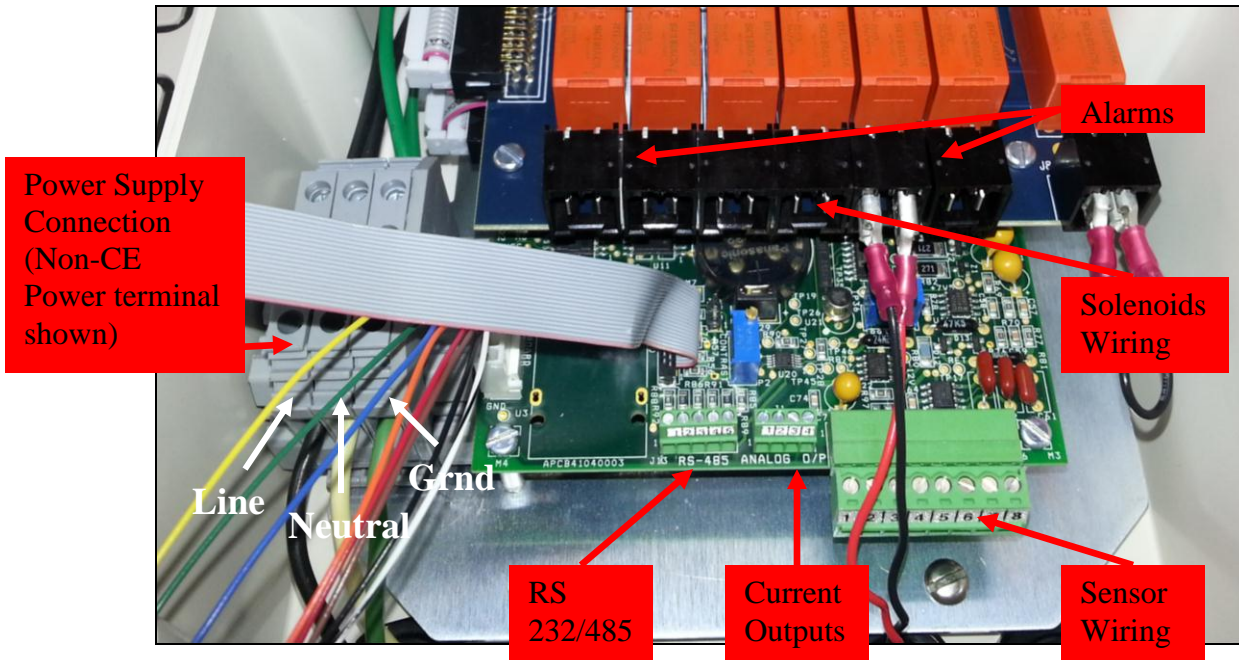

**Figure 13.** Location of the terminal block connections in the transmitter unit.

**⚠WARNING.** Although this instrument has internal fuse protection, the operator must use a suitably rated external protection device such as a fuse or miniature circuit breaker (MCB).  
 Switch **OFF** the power supply and high voltage power-operated control circuits before making any connections. This equipment operates on alternating current (AC) electricity. Always take suitable safety precautions to avoid the possibility of an electric shock.

**⚠WARNING.** Connecting the power supply earth (ground) ensures the safety of assembly personnel, reduction of the effects of Radio Frequency Interference (RFI), and ensures operation of the power supply interference filter.

### 2.5.5 AC POWER TERMINAL BOX (OPTIONAL)

If user wishes to hard wire the system they can use an optional AC Power Terminal Box (P/N P1000-059).

If the user requires CE certification this box is mandatory.

The user can turn ON/OFF power to the analyzer by pressing the **GREEN** button on the terminal box. When power is supplied to the analyzer the button will illuminate. The terminal box has IP66 rating and contains 3 AC power lines (LINE, GOUND, NEUTRAL) input and output. Picture of terminal box is shown below:



### 2.5.6 CE POWER CONNECTIONS (OPTIONAL)

For analyzers that are CE certified, the AC power box must be used (above). The power connections from the AC power box to the transmitter power terminal are shown below:

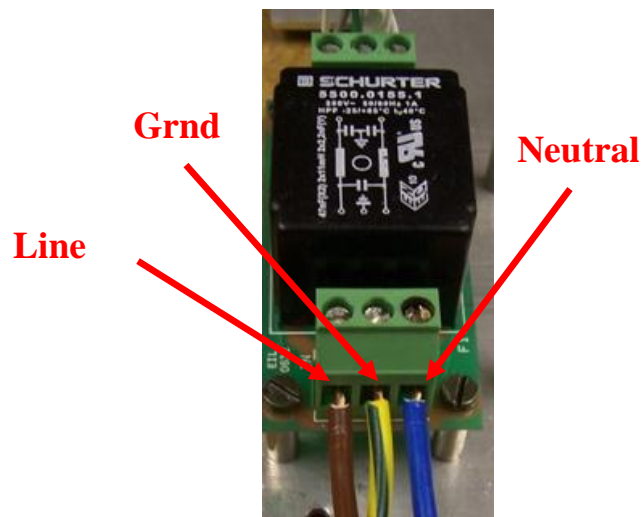

**2.5.7 WIRING TO TRANSMITTER**

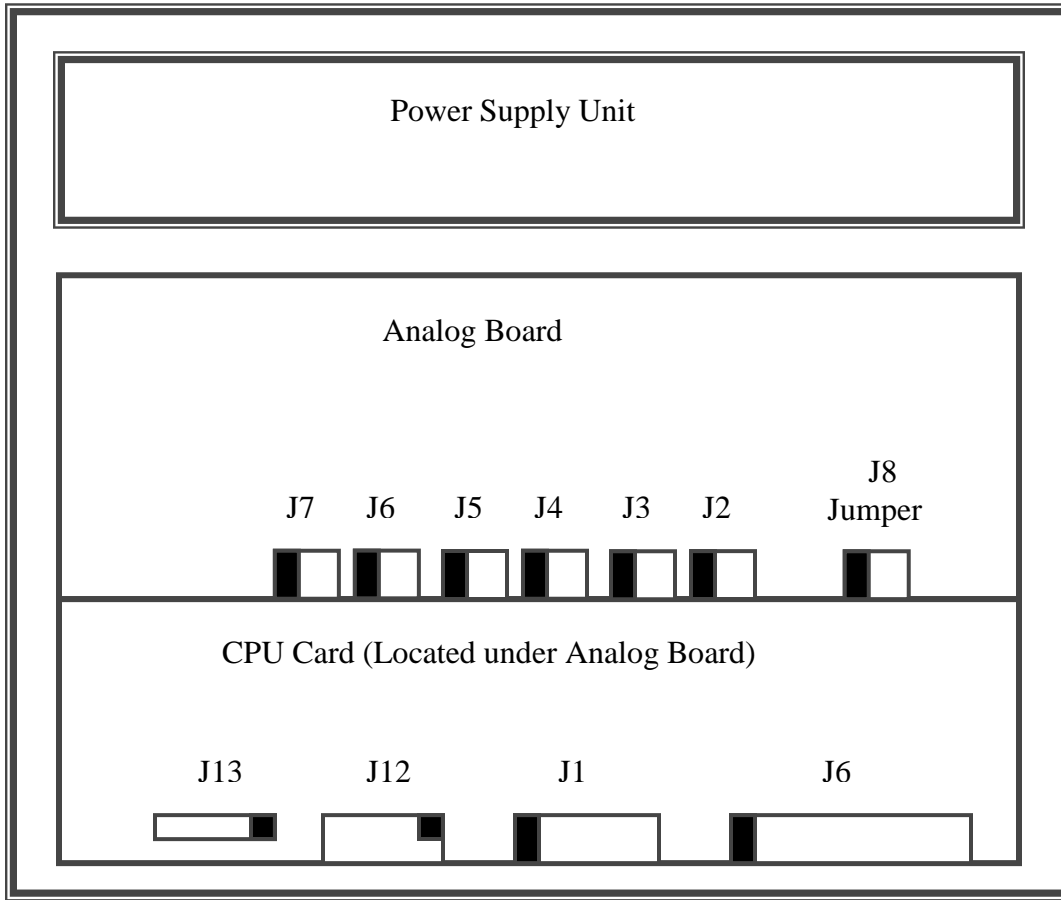

**Note: Pin 1 of all the connectors are shown in black**

ANALOG BOARD CONNECTIONS						
TO CPU BOARD	LOW ALARM	HI ALARM	NOT USED	NOT USED	SOLENOID 1	GENERAL ALARM
	J7	J6	J5	J4	J3	J2
	- +	- +	- +	- +	- +	- +
					BLK RED	
						24V
						- +
						NOT USED
						J8
						- +
						JUMPER

**Figure 14.** Pin locations for the Analog and CPU cards.





The Analog board is mounted above the CPU card. The CPU and Analog cards communicate with each other through a common flat ribbon cable and mating connectors. Power supply to the respective cards is routed through common cables and connectors.

The approximate dimensions of the PCB sub-assemblies are as follows:

CPU card - 131.5 mm (L) x 130 mm (W)

Analog Board – 131.5 mm (L) x 100 mm (W)

Power Supply cards x 2 – 127 mm (L) x 76.2 mm (W) [Housed in common enclosure]

All field I/Os are routed inside the instrument via cable glands. All field I/Os for the sensor inputs are terminated on PHOENIX connector terminals. The terminal receptacle is a “90 ° Block Header” with “socket to pin orientation” and the Plug is 180° “wire to plug” orientation. The plug accepts a 30-14 AWG wire.

Connections to the Analog board are terminated via crimp terminals. Refer to the appendix in the back of the manual for instructions on properly crimping terminals to the wire ends.

**Connecting the Pre-amp Output to Transmitter:**

The 8-Core PVC shielded cable coming as an output from the pre-amplifier is connected to J6 of CPU Card, as follows:

- Pin 1 (Black Wire)
- Pin 2 (White/Black Wire).
- Pin 3 (Red Wire)
- Pin 4 (White Wire)
- Pin 5 (Red/Black Wire)
- Pin 6 (Green Wire)
- Pin 7 (Blue Wire)
- Pin 8 (Orange Wire)

Card	Connector	Pin Number	Wire Color
CPU	J6	1	Black
CPU	J6	2	White/Black
CPU	J6	3	Red
CPU	J6	4	White
CPU	J6	5	Red/Black
CPU	J6	6	Green
CPU	J6	7	Blue
CPU	J6	8	Orange

**Connecting the Current Output(s) to Transmitter:**

Two 4-20mA current outputs supplying analog output proportional to the sodium concentration are provided on J1 connector on the CPU card. The pin locations from the connector are shown below:

Card	Connector	Pin Number	Connection
CPU	J1	1	Iout1
CPU	J1	2	FGnd
CPU	J1	3	Iout2
CPU	J1	4	FGnd

Note: In case no load is connected, it is advisable to connect a 470-ohm load resistor between Pin 1 & 2 and Pin 3 & 4 respectively.

**Connecting the Alarm(s) outputs to Transmitter:**

Potential free contacts for High Alarm and Low Alarm are terminated on the J6 and J7 connectors (provided on the Analog Board) as shown in Figure 12.

The pin out of the connector is as shown below:

Card	Connector	Alarm/Solenoid	Pin Number	Connection
Analog	J7	Low Alarm	1	-
Analog	J7		2	+
Analog	J6	High Alarm	1	-
Analog	J6		2	+

Similarly, potential free contacts for General Alarm are terminated on the J2 connector (provided on the Analog Board) as shown in the Figure 12.

The pin out of the connector is as shown below:

Card	Connector	Alarm/Solenoid	Pin Number	Connection
Analog	J2	General Alarm	1	-
Analog	J2		2	+

**Connecting the Solenoids to Transmitter:**

Solenoid valve used for CAL is terminated on the J3 connector, provided on the Analog Board, as shown in Figure 12. The +24V DC excitation @ 400mA, each, is provided on board.

The pin out of the connector is as shown below:

Card	Connector	Alarm/Solenoid	Pin Number	Connection
Analog	J3	Solenoid 1 (CAL1)	1	S1- (BLK)
Analog	J3		2	S1+ (RED)

**Connecting the serial communication ports to Transmitter:**

Two separate serial ports RS-232 and RS-485 are provided on the CPU card. These ports are located near connector J1.

The pin out of the connector is as shown below:

Card	Connector	Serial Com	Pin Number	Connection
CPU	J12	RS-232	1	NC
CPU	J12		2	RxD
CPU	J12		3	TxD
CPU	J12		4	NC
CPU	J12		5	Gnd
CPU	J12		6	NC
CPU	J12		7	NC
CPU	J12		8	NC
CPU	J12		9	NC
CPU	J12		10	NC

Card	Connector	Serial Com	Pin Number	Connection
CPU	J4	RS-485	1	NC
CPU	J4		2	Data+
CPU	J4		3	Data-
CPU	J4		4	NC
CPU	J4		5	Gnd
CPU	J4		6	NC
CPU	J4		7	NC
CPU	J4		8	NC
CPU	J4		9	NC
CPU	J4		10	NC

### 3 OPERATING THE ANALYZER

#### 3.1 ANALYZER OPERATION

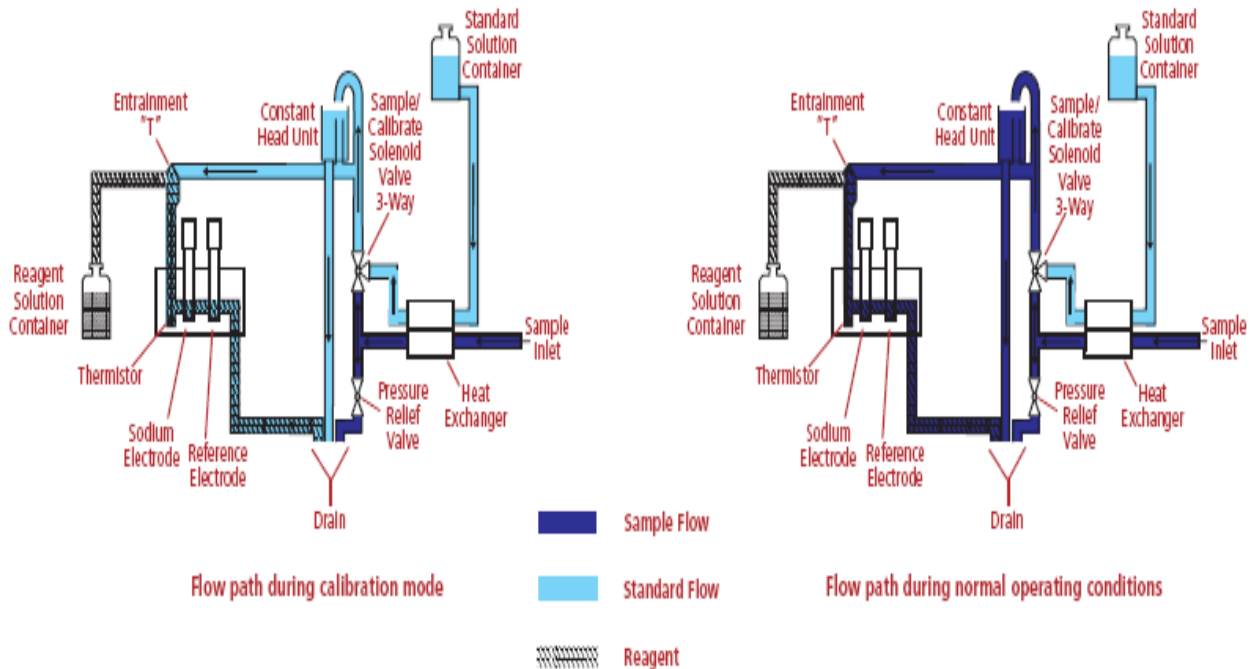

**Figure 15.** Sample flow during normal operation.

The 9031C Sodium analyzer system is comprised of separate combination sheet metal and plastic enclosures. The internal hydraulic components and pipe work are mounted onto a sample panel connected to the cabinet. Sample enters through the inlet compression fitting at the bottom of the case and first passes through the heat exchanger. The heat exchanger is used to keep the sample temperature and calibration solutions temperature at equilibrium during calibration. Drastic and sudden changes in solution temperature may have a negative effect on electrode performance.

After flowing through the heat exchanger, the sample passes through a 3-way solenoid valve. After the valve the sample flows through the constant head (the constant head unit stabilizes the effect of changes in sample inlet flowrate). After flow passes through the constant head piece it is then delivered to the entrainment 'T' where an alkaline vapor buffer is added to the sample in order to raise the pH value. After the sample and vapor reagent are mixed, the solution is sent to the flowcell where it comes into contact with the sodium and reference electrodes.

The sample flows past the electrodes and exits the flowcell through the drain located in the bottom of the case. The potential developed between the sodium measuring (ion-responsive) electrode and calomel reference electrode is logarithmic with respect to



changes in sodium ion concentration. The signal from the electrodes is fed to the pre-amplifier, which converts the voltage into current. The output from pre-amplifier is then sent to the transmitter unit via the interconnection cable.

A temperature sensor (thermistor) is housed in the flow cell and detects the temperature of the sample. The thermistor is connected to the transmitter unit and compensates for changes in output from the electrode pair over a range of 41°F to 131°F (5 °C to 55°C).

Calibration of the analyzer is controlled by the micro-controller. After the user connects the transmitter unit to the wet section, it is necessary to perform one successful two point calibration. See Section 3.7 for more details on calibration. Once a successful calibration is performed, the unit is now ready to measure the sodium concentration in the sample. The display then shows the ppm/ppb concentration of the sample while the analyzer compensates for the variations in the sample temperature automatically.

### 3.2 ALARMS

#### Sample Concentration Alarms

When the 9031C Sodium system is in normal operation mode one alarm operates as a “low” alarm and the other operates as a ‘high’ alarm. Alarm 1 (A1) operates as a LOW alarm and is activated when the sodium level decreases below the set value. Alarm 2 (A2) operates as a HIGH alarm and is activated when the sodium level increases above the set value. The two sodium alarms control the relays provided. Each relay has one pair of changeover contacts rated at 2A, 250VAC (non-inductive). The terminal connections for alarm relays are located at J2, J6, and J7 of the Analog card.

CONCENTRATION ALARM DESCRIPTIONS		
Symbol	ALARM	DESCRIPTION
A1	Low Alarm	Activates when Na in sample feed is lower than “Low Set Point”.
A2	High Alarm	Activates when Na in sample feed is higher than “High Set Point”.

#### Various Alarm Descriptions

ALARM	DESCRIPTION
CF	Calibration Fail
HOT	Sample temperature over range (131F)
TEMP	No thermistor response
Output 1 Out	Concentration is outside O/PmA 1 set range
Output 2 Out	Concentration is outside O/PmA 2 set range
Conc. Low	Concentration is below Low Alarm set point
Conc. High	Concentration is above High Alarm set point
OVR	Concentration is above limits of analyzer (>10ppm)

### 3.3 GETTING STARTED

- Insert the POWER cord in the AC mains socket terminal connector located in transmitter section and switch ON the system. The power up sequence should be as mentioned in [Section 3.4](#). After power-up, the analyzer enters into Measurement Mode.
- The analyzer automatically displays the concentration of sodium interpreted by the electrodes. Units of measurement (ppb/ppm) are displayed on the right-hand-side on the LCD.
- If the analyzer is being started up for the first time, or if it was not in operation for a long time, the user should perform a calibration as detailed in [Section 3.7.2](#).

### 3.4 POWER UP SEQUENCE

- After switching ON the analyzer the following start up sequence is displayed:

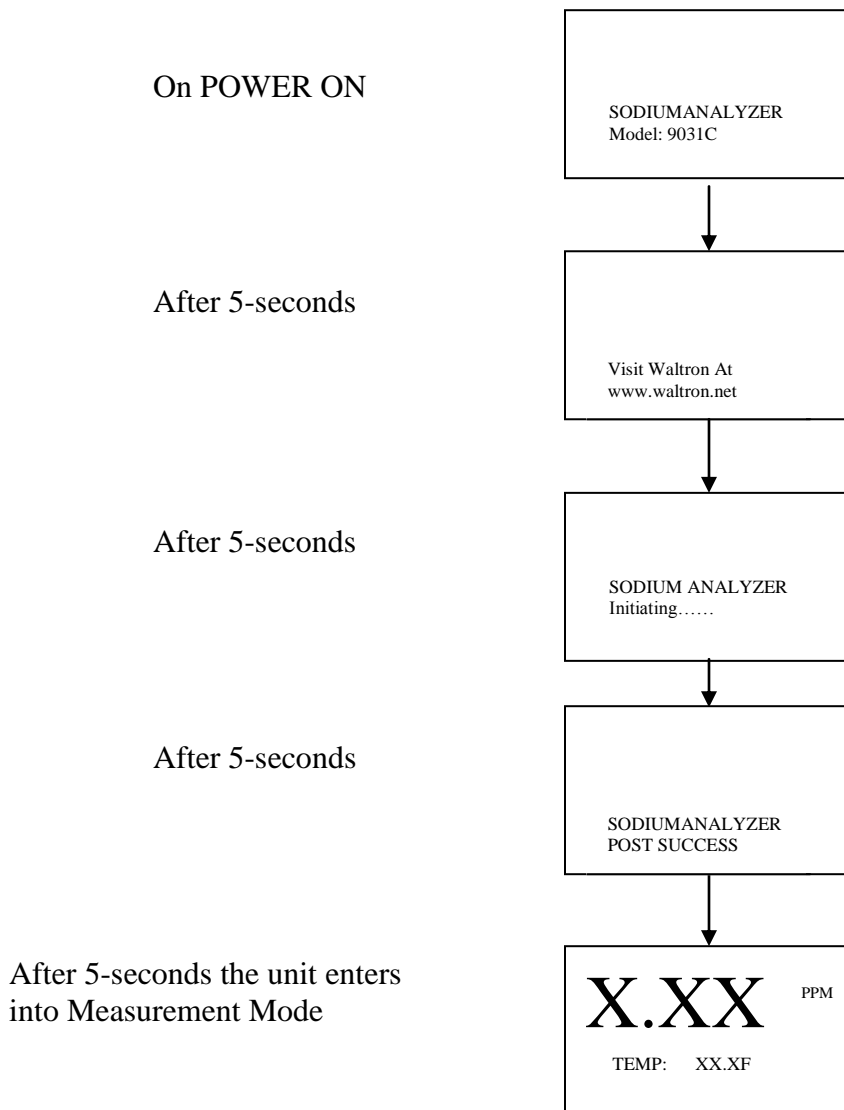

### 3.5 KEY-BOARD FUNCTIONS



**Figure 16.** The front panel of the transmitter unit

There are four keys on front panel (shown in above) which are used to navigate/view/edit the various menus/parameters. The functionality of the keys is described below:

- **MENU:** The MENU key can be pressed at any time to return to the Main Menu. When the MENU key is pressed the Main Menu options are displayed. There are 7 Main Menu options and only 2 main/sub menus are displayed at a time, on two separate lines.
- **DOWN ARROW:** By pressing this key the user can navigate through the various menu and sub-menu options. This same key also functions as an increment key during numerical entry.
- **RIGHT ARROW:** This key is used to position the cursor at desired place; the cursor moves in a left to right direction.
- **ENTER:** This key is used to enter into a selected menu. It is also used to confirm/store entered values.



### 3.6 MAIN MENU - ANALYZER MODES

There are 7 Main Menu options; each is listed below:

1. **MEASUREMENT** – Displays information during normal operation
2. **CONFIGURATION** – Used to configure analyzer settings
3. **MANUAL CALIB** – Perform manual calibration
4. **FAIL SAFE** – Used to shut-down/power off analyzer
5. **DIAGNOSTICS** – Stores data logs and aids in troubleshooting
6. **DISPATCH MODE** – Used to troubleshoot/calibrate electronics

To enter the Main Menu press MENU Key. The following screen is displayed:

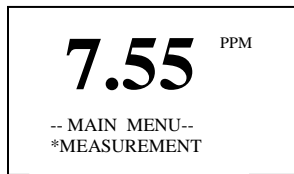

Note: The ‘\*’ indicates the selected item of that particular menu or sub-menu.

#### 3.6.1 MEASUREMENT

Press the ENTER key to go to MEASUREMENT screen. The display shows:

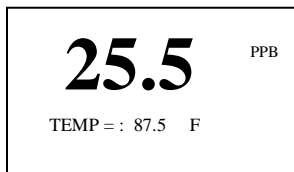

Or

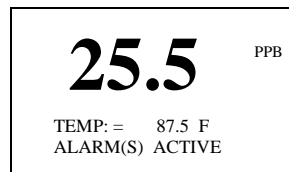

Use the DOWN arrow key to view any active alarms.

**Note:** The system loops backs to the MEASUREMENT mode and displays the measurement screen if there is no keypad activity for 60 seconds.

#### 3.6.2 CONFIGURATION

To go to the CONFIGURATION menu press the DOWN arrow key once to display the following screen:

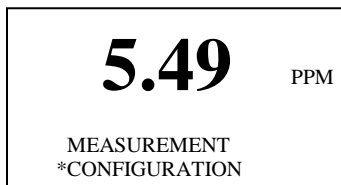



Press the ENTER key to enter CONFIGURATION menu; the following sub-menu is displayed:



Press the DOWN ARROW key to scroll down the remaining sub-menus. The CONFIGURATION menu has the following 7 sub-menus:

1. **CALIB SETUP** – View/change frequency and settings for manual/auto calibration
2. **O/P mA SETUP** – View/change settings for current output (4-20mA) alarms
3. **ALARM SET PTS** – View/change settings for High/Low/General Alarms
4. **DATE & TIME** – View/change date and time settings
5. **SERVICE PARAMS** – Password protected; controls valve timing during CAL
6. **SERIAL PORT** – View/change settings used for remote interface communication
7. **PREVIOUS MENU** – Reverts back to previous menu (Main Menu)

To navigate through the sub-menus press the DOWN arrow key and to select an item from the menu press the ENTER key whenever that sub-menu item is highlighted (\* ‘). The logical flow is shown below. For simplicity all the sub-menus are shown at once.

### 3.6.2.1 CALIB SETUP (Calibration Set-Up)

The sub-menus for CALIB SETUP are as follows:

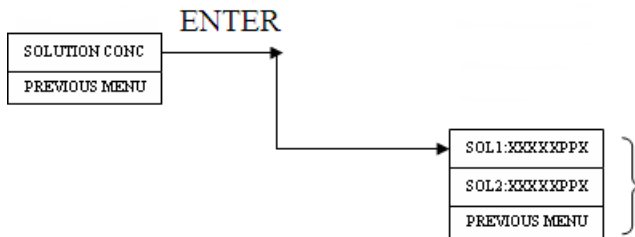

- “XXX.XX” and the last character of PPX all editable parameters.
- Press RIGHT arrow key  
Once: To select the first ‘ X’.  
Twice: To select the 2nd ‘ X’  
Thrice: To select the 3rd ‘ X’  
Four times: To select the 4th ‘ X’  
Five times: To select the 5th ‘ X’
- After selecting any of the ‘X’s use the UP arrow key to increment and press ENTER key to confirm.
- Pressing the ENTER key when the PREVIOUS MENU is displayed, loops back the display to the previous menu.

### 3.6.2.2 O/P mA SETUP

Press the ENTER key when O/P mA menu is displayed. The following sub-menus are displayed:

O/P1 PARAMETERS
LOW: XXXXXPPX
HIGH : XXXXXPPX
O/P2 PARAMETERS
LOW: XXXXXPPX
HIGH : XXXXXPPX
PREVIOUS MENU

- “XXX.XX” and the last character of PPX all editable parameters.
- Press RIGHT arrow key  
Once: To select the first ‘ X’  
Twice: To select the 2nd ‘ X’  
Thrice: To select the 3rd ‘ X’  
Four times: To select the 4th ‘ X’  
Five times: To select the 5th ‘ X’
- After selecting any of the ‘ X’s use the DOWN arrow key to increment and press ENTER key to confirm.
- Pressing the ENTER key when the PREVIOUS MENU is displayed loops back the display to the previous menu. . i.e, O/P mA SETUP

### 3.6.2.3 ALARM SET PTS

Press the ENTER key when ALARM SET PTS menu is displayed. The following sub-menus are displayed:

LO: XXXXXPPX
HI: XXXXXPPX
PREVIOUS MENU

- “XXX.XX” and the last character of PPX all editable parameters.
- Press RIGHT arrow key  
Once: To select the first ‘ X’  
Twice: To select the 2nd ‘ X’  
Thrice: To select the 3rd ‘ X’  
Four times: To select the 4th ‘ X’  
Five times: To select the 5th ‘ X’
- After selecting any of the ‘ X’s use the DOWN arrow key to increment and press ENTER key to confirm.
- Pressing the ENTER key when the PREVIOUS MENU is displayed loops back the display to the previous menu.i.e, ALARM SET PTS

### 3.6.2.4 DATE & TIME

Press the ENTER key when DATE & TIME menu is displayed. The following sub-menu options are displayed:

SET DATE & TIME
DATE: DD/ MM/ YY
TIME: HH:MM:SS
PREVIOUS MENU

- DD, MM, SS, HH MM, SS are all editable parameters where DD is the Day, MM the Month, YY the Year, HH the Hours, MM the Minutes and SS the Seconds.
- Press RIGHT arrow key  
Once: To select ‘DD’.  
Twice: To select ‘MM’  
Thrice: To select ‘YY’
- The highlighted value may be changed using the DOWN arrow key to increment and followed by ENTER key to confirm.
- Pressing the ENTER key when the PREVIOUS MENU is displayed loops back the display to the previous menu.i.e, DATE & TIME



The above explanation is true while editing TIME also.

### 3.6.2.5 SERVICE PARAMATERS

1. Press ENTER key when Service Params menu is displayed. This menu is password protected and these default settings should not be changed.
2. Enter password by pressing menu key, down arrow key, right arrow key, enter key.
3. Use down arrow key to select temperature display unit and press ENTER key to confirm.
4. Use the down arrow key to select REC O/P CALIB
  - a. Use Offset to adjust the 4 mA output
  - b. Use Span to adjust the 20 mA output
5. Do NOT change the other default menu settings.
6. Pressing the ENTER key when the PREVIOUS MENU is displayed loops back the display to the previous menu.

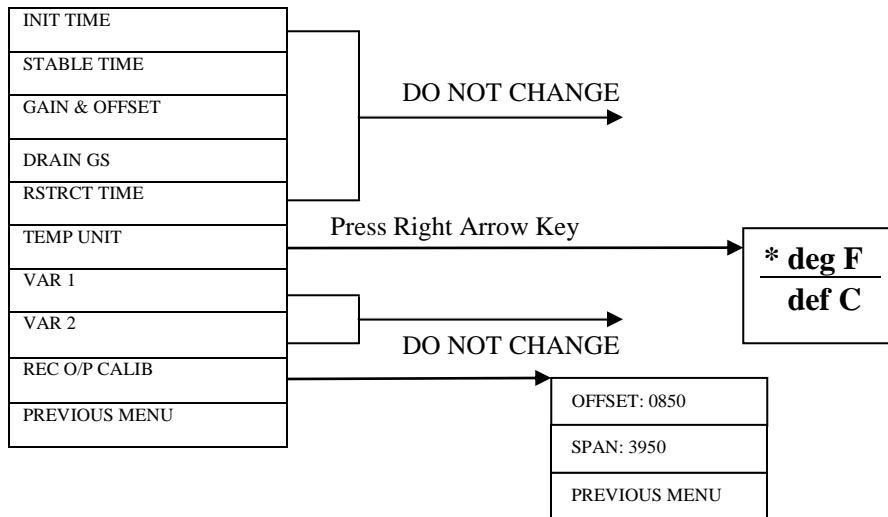

### 3.6.2.6 SERIAL PORT

Press the ENTER key when SERIAL PORT menu is displayed. The following sub-menus are displayed:

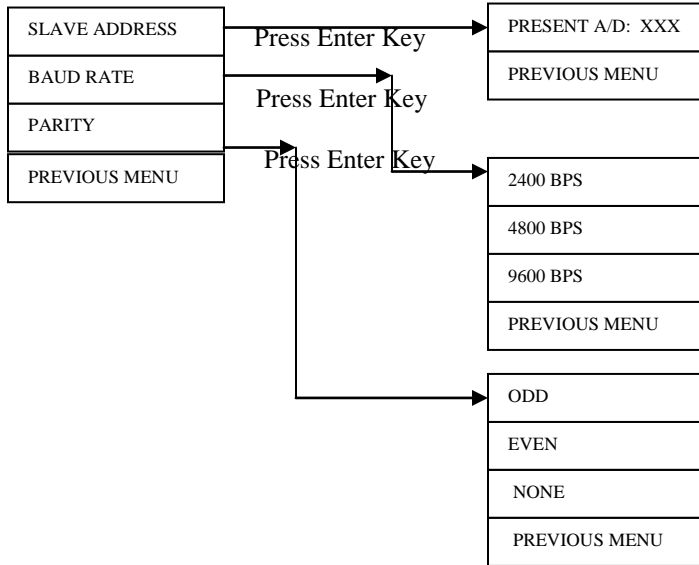

- “XXX” are all editable parameters.
- Press RIGHT arrow key  
Once: To select the first ‘X’.  
Twice: To select the 2nd ‘X’  
Thrice: To select the 3rd ‘X’
- After selecting any of the ‘X’s use the UP arrow key to increment and press ENTER key to confirm.
- Use UP arrow key to select and highlight baud rate /parity.
- Pressing the ENTER key when the PREVIOUS MENU is displayed loops back the display to the previous menu.

### 3.6.2.7 PREVIOUS MENU

Pressing the ENTER key when the PREVIOUS MENU is displayed loops back the display to the previous menu.

### 3.6.3 MANUAL CALIBRATION

Go to the MANUAL CALIB menu and press ENTER; the following screen will appear:

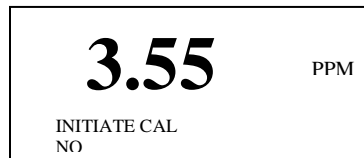

Press ENTER key

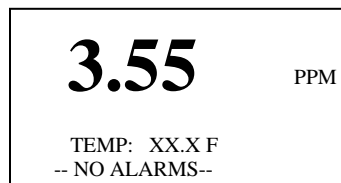

Else, press DOWN arrow key

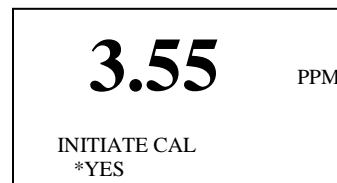



MANUAL CALIB mode has following sub-menus:

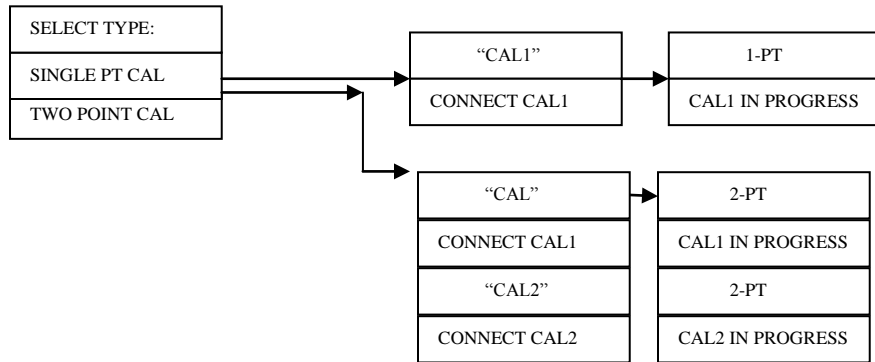

To interrupt CAL and end cycle press ENTER key. The menu guides you through the abort process.

The analyzer will prompt user to manually change CAL solutions at end of CAL1 cycle.

- "XXX" are all editable parameters.
- Press RIGHT arrow key  
Once: To select the first 'X'.  
Twice: To select the 2nd 'X'.  
Thrice: To select the 3rd 'X'
- After selecting any of the 'X's use the DOWN arrow key to increment and press ENTER key to confirm.

### 3.6.4 FAIL SAFE

This mode is used to perform a safe shut down so that the necessary parameters and changed default values are properly saved. To perform a safe shutdown go to the FAIL SAFE mode and press ENTER.

To go to the FAIL SAFE menu press the MENU key to get to MAIN MENU. Press DOWN arrow key to FAIL SAFE and press ENTER. The display will show the following screen during shutdown:

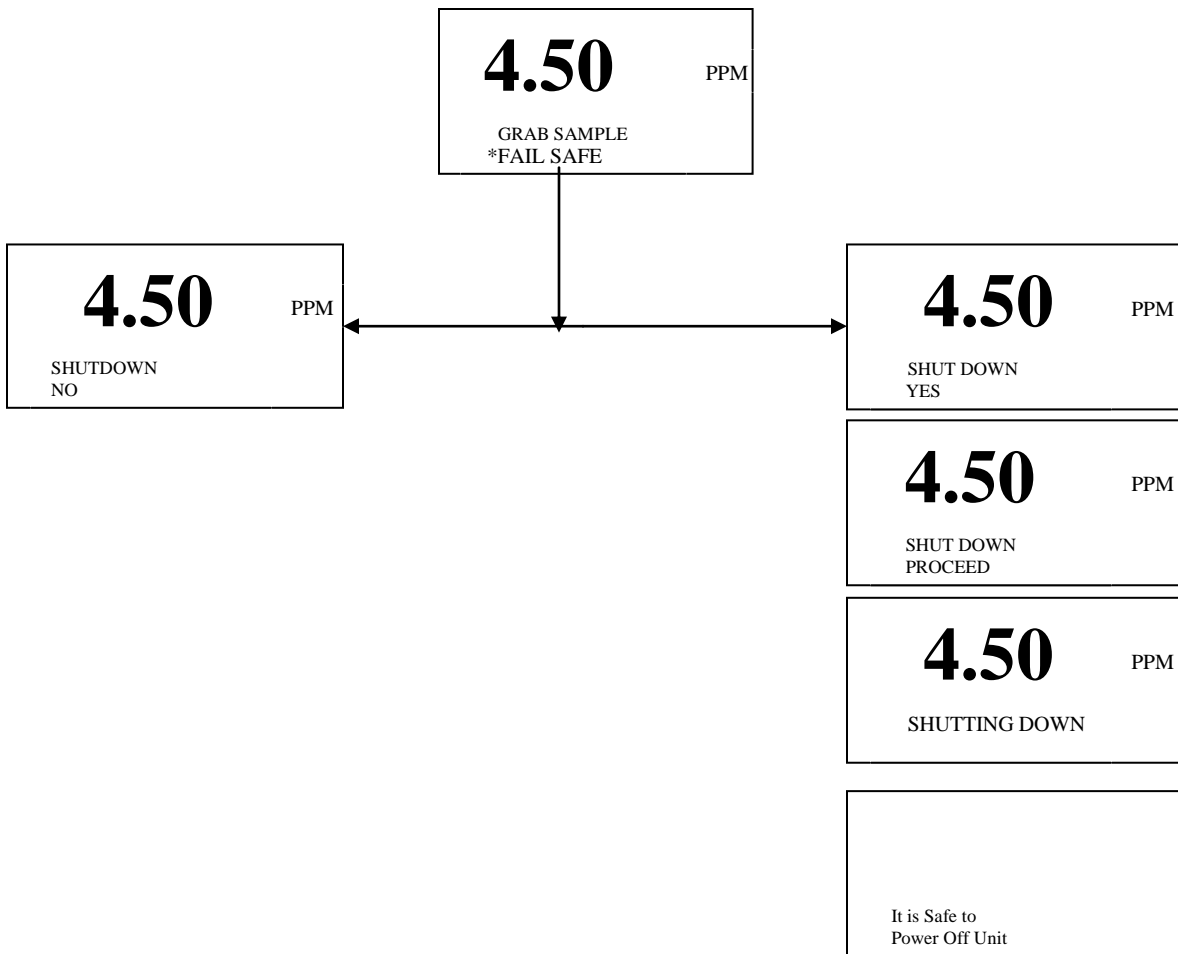

**NOTE: Switching off the system abruptly, without going into FAIL SAFE mode may result in malfunctioning of the system after next power ON.**

### 3.6.5 DIAGNOSTICS

A complete set of diagnostics is provided so that various system parameters and diagnostic tasks such as switching relays ON/OFF, activating/de-activating the alarms and viewing logs may be carried out quickly and easily.

To access diagnostic parameters press the MENU key to get to MAIN MENU and go into the DIAGNOSTICS menu and press ENTER to display the following screen:

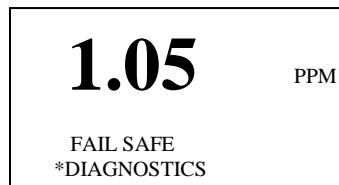

Press the ENTER key to display the sub-menus. The display shows:

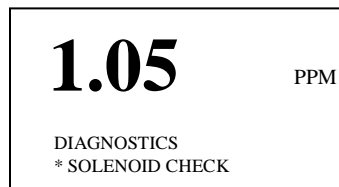

The DIAGNOSTICS menu has the following sub-menus:

1. **SOLENOID CHECK** – Manually checks the operation of solenoid valve
2. **CALIB LOG** – Stores data for the last 10 calibrations
3. **ALARM LOG** – Stores data for the last 10 alarms
4. **PROBE DETAILS** – Input probe data for historical record
5. **THERM CHECK** – Checks real-time output from thermistor
6. **SENSOR CHECK** – Check real-time output from probes
7. **RELAY CHECK** – Checks status of relays
8. **O/P mA CHECK** – Manually sends 4-20mA outputs
9. **DIGITAL I/PS** – Checks status of digital I/Ps
10. **SERIAL CHECK** – Checks communication of serial port
11. **S/W VERSION** – Shows current version of software
12. **PREVIOUS MENU** – Returns to previous menu (Main Menu)

To navigate through the sub-menus, press the ENTER key whenever the sub-menu is highlighted (\* ‘).

### 3.6.5.1 SOLENOID CHECK

This mode is used to check the operation/status of the solenoid valves. To perform a Solenoid Check go into the DIAGNOSTICS menu and select SOLENOID CHECK. The menu layout of the solenoid check cycles is as follows:

Press the DOWN arrow key to select which valve you want to initiate. Press ENTER to activate valve.

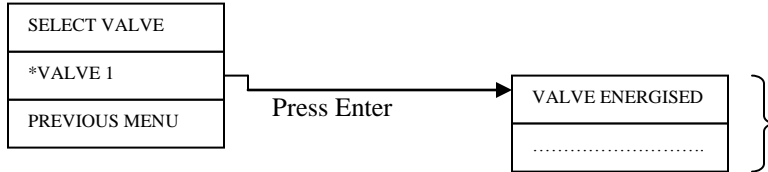

Press DOWN, RIGHT and ENTER keys to go to previous sub menu.

### 3.6.5.2 CALIBRATION LOG

The Calibration Log (CALIB LOG) stores the relevant data taken during a calibration. The data for each CALIB LOG is stored on 2 separate pages (press the RIGHT arrow key to toggle between pages).

Select CALIB LOG in DIAGNOSTICS menu and press the ENTER key. The following screen is displayed:

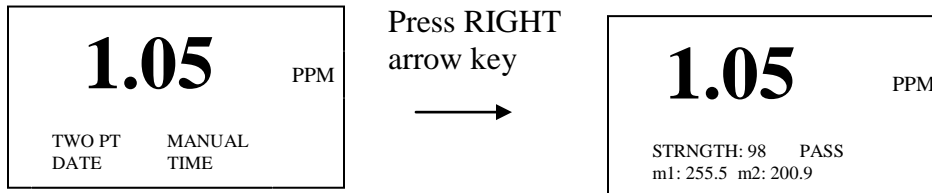

The **first** page of the CALIB LOG shows:

- Calibration---→Single PT, Two Point
- Type-----→ Manual
- Date----- → Date of Calibration
- Time----- → Time of Calibration

The **second** page of the CALIB LOG shows:

- Strength---→Calibration performance
- PASS/FAIL-----→Calibration result
- m1----- → mV seen during CAL1 (100ppb) sequence
- m2----- → mV seen during CAL2 (1ppm) sequence

To view the logs use the DOWN arrow key. A maximum of 10 logs are maintained in memory.





### 3.6.5.3 ALARM LOG

By pressing the ENTER key the following screen is displayed:

A log typically shows the:

Alarm Name → Output1 Set, Conc. High Set etc.

Date----- → Date of Alarm

Time----- → Time of Alarm

To view the logs use the DOWN arrow key.

A maximum of 10 Logs are maintained in memory.

### 3.6.5.4 PROBE DETAILS

Upon pressing the ENTER key a screen asking for a password is displayed.

After entering the correct password the following screen is displayed:

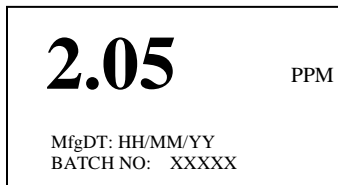

The MfgDT is the editable part of this menu. The editing procedure is same as explained in the DATE AND TIME section.

### 3.6.5.5 THERM CHECK

By pressing ENTER key the following screen is displayed:

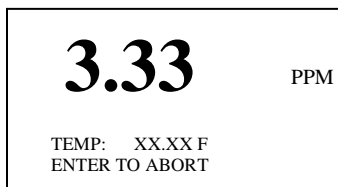

Press the ENTER key to abort. The system will then loop back to the Previous Menu. If no key is pressed the system will loop back to the MEASUREMENT screen after 30 seconds.



### 3.6.5.6 SENSOR CHECK

By pressing ENTER key the following screen is displayed:



Press ENTER key to abort and go to the previous menu.

### 3.6.5.7 RELAY CHECK

By pressing ENTER key the following screen is displayed:

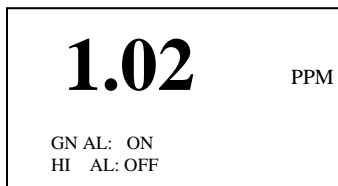

Press DOWN arrow key twice to get the following display:

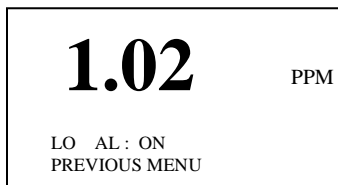

This menu is used to test the Alarms. Select the sub-menu by pressing the DOWN arrow key and pressing ENTER. Use the RIGHT arrow key to select the relay and DOWN arrow key followed by ENTER key to activate or de-activate the alarms.

Pressing the ENTER key when PREVIOUS MENU is highlighted loops the system to previous menu.

### 3.6.5.8 OUTPUT mA CHECK

By pressing the ENTER key the following screen is displayed:

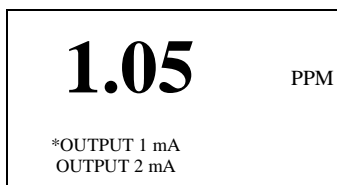



By default OUTPUT 1 mA is highlighted. Use DOWN arrow key to select OUTPUT 1 mA or PREVIOUS MENU.

Press ENTER to display the following:

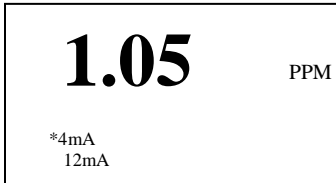

Press DOWN arrow key to display the next option:



Press ENTER key to display the following:

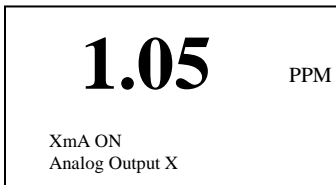

Pressing the PREVIOUS MENU key loops back the system to the previous menu.

### 3.6.5.9 DIGITAL I/PS

By pressing the ENTER key the following screen is displayed:



The line "XXXXX..." corresponds to status of digital I/Ps. Press any of the four keypad keys to see a change in state. This screen can be aborted only by leaving the keyboard idle for at least 60 seconds.



### 3.6.5.10 SERIAL CHECK

By pressing the ENTER key the following screen is displayed:

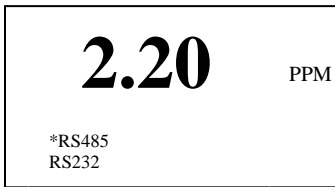

Select the type of communication (RS485 or RS232) by pressing the DOWN arrow key and press ENTER to check the serial outputs. User should get the following display:



Press the RIGHT arrow key or DOWN arrow key to go to the previous menu.

### 3.6.5.11 S/W VERSION

By pressing the ENTER key the following screen is displayed:

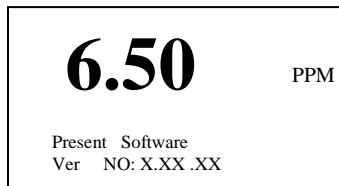

Press any key to go back to the previous menu.

### 3.6.5.12 PREVIOUS MENU

Selecting PREVIOUS MENU loops the system back to the previous menu.

## 3.6.6 DISPATCH MODE

**\*\*DISPATCH MODE is to be used for Waltron in-house testing only.\*\***

To go to the DISPATCH MODE menu press the MENU key and the DOWN arrow key six times and then press the ENTER key to display the following screen:





Please enter the password.

The following is displayed:



After connecting the mA source and pressing ENTER key, or after 30 seconds, the following screen is displayed:

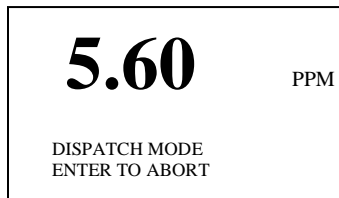

The system is now in DISPATCH MODE.

To abort press the ENTER key. The user-friendly menus guide you through the abort process.



### 3.7 CALIBRATION PROCEDURE

A 2-Point CAL must be performed (and passed) for the instrument to function correctly. Before initiating a calibration sequence, please rinse the two standard solution containers with high-purity (DI) water and fill them with fresh sodium standard solutions. If the user wishes to perform a single point calibration, only one standard solution CAL1 (100ppb standard) is required. If the user wishes to perform a two point calibration, both the CAL1 (100ppb) and CAL2 (1ppm) standards are required.

The frequency of calibrations depends on the operating conditions and electrode conditions. Waltron recommends performing a 2-Point CAL at least once a month however more frequent calibrations may be done to eliminate drift due to changing electrode response.

Please be sure the following tasks are performed **before** executing a CALIBRATION cycle:

- 1) Low concentration solution (100ppb) is placed in the container CAL1 (LOW).
- 2) High concentration solution (1ppm) is placed in the container CAL2 (HIGH).
- 3) The high and low solution concentrations need to be entered in the system under CALIBRATION SETUP. Refer to Section 3.5.2.1 for more details.

#### 3.7.1 SINGLE POINT CALIBRATION

A Single Point (1-Pt) calibration should be performed only if the analyzer has successfully passed a 2-Pt calibration. For 1-Pt calibration, the solenoid valve is energized and CAL1 solution flows through the flow cell. During a 1-Pt calibration the analyzer calibrates by changing the **offset** of the slope taken during the last 2-Pt calibration.

##### **To perform 1-Pt Calibration:**

- 1) Press the MENU key.
- 2) Press the DOWN arrow key to scroll to MAN CALIB menu and press ENTER key to select.
- 3) Select PROCEED. The sub-menu gives the user the option to select the type of calibration.
- 4) Scroll to Single PT CALIB and press ENTER.

”CAL1”

CONNECT CAL1  
ENTER TO PROCEED

- 5) Once a 1-Pt calibration is in progress the following message is displayed on the bottom 2 lines of the LCD:

1-PT

CAL1 IN PROGRESS  
SENSOR: XXX.XXmV

- 6) After successfully completing 1-Pt calibration the following message is displayed and the system returns to the normal measurement mode:

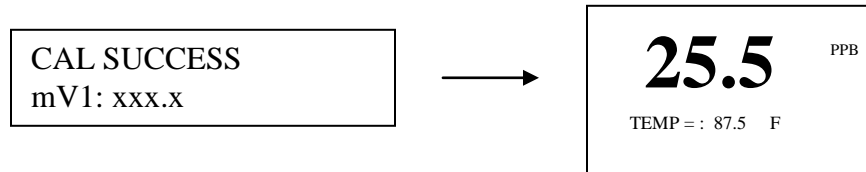

In case of CAL FAIL the system displays the following message.

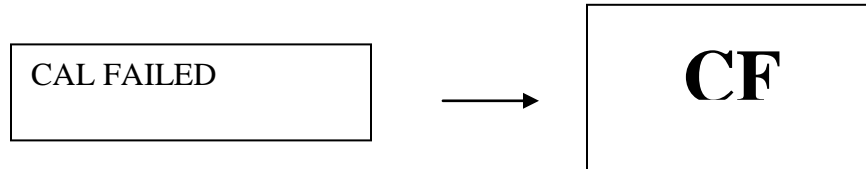

### 3.7.2 TWO POINT CALIBRATION

During a 2-Pt calibration the solenoid valve is first energized and CAL1 solution flows through the flow cell. Once analyzer finishes measuring the CAL1 solution, the solenoid valve is deactivated and the analyzer prompts the user to connect calibration tubing to CAL2 standard. Once CAL2 bottle is connected the user must press ENTER and the solenoid is again activated thus allowing CAL2 solution to flow through the flowcell. The analyzer calibrates by measuring the change in mV values between the CAL1 and CAL2 solutions and comparing this “strength” (sometimes called “slope”) to theoretical values.

#### **To perform 2-Pt Calibration:**

1. Press the MENU key.
2. Press the DOWN arrow key to scroll to MAN CALIB menu and press ENTER key to select.
3. Select PROCEED. The sub-menu gives the user the option to select the type of calibration.
4. Scroll to TWO PT CALIB and select ENTER.

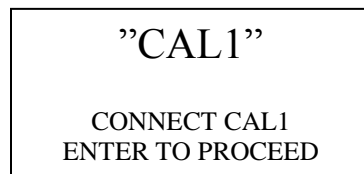

5. Once 2-Pt calibration is in progress CAL1 solution will begin flowing into the system and the following is displayed on the bottom 2 lines of the LCD:

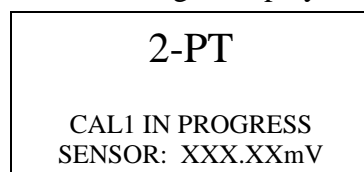

6. After CAL1 is finished, “CAL2” will begin flashing on the display. The user must disconnect tubing from CAL1 bottle and connect to CAL2 bottle.

"CAL2"  
CONNECT CAL2  
ENTER TO PROCEED

7. Once connected the user must hit ENTER and the CAL2 solution will begin flowing into the system and the following message is displayed:

2-PT  
CAL1 IN PROGRESS  
SENSOR: XXX.XXmV

8. After successfully completing the 2-Pt calibration the following message is displayed and the system returns to the measurement mode:

CAL SUCCESS mV1: xxx.x mV2:xxx.x	→	<div style="font-size: 2em; font-weight: bold;">25.5</div> <div style="font-size: 0.8em;">PPB</div> <div style="font-size: 0.8em;">TEMP = : 87.5 F</div>
-------------------------------------	---	--

In case of CAL FAIL the system displays the following message:

CAL FAILED	→	<div style="font-size: 2em; font-weight: bold;">CF</div>
------------	---	--

**Note: A calibration cycle may be interrupted at any time by pressing the ENTER key. In order to avoid accidental key press, the calibration cycle is aborted only after confirmation from the user. Once the calibration process is aborted, the measurement screen is displayed.**

### 3.7.3 CALIBRATION FAILURE

A Calibration Fail (CAL FAIL) condition will occur after a 2-Pt calibration if the electrode response does not meet requirements. This happens when the electrodes “strength” (“slope”) from a 2-Pt calibration is below 83 or greater than 110. This could be caused by a number of factors (See next section - Troubleshooting).





## **4 TROUBLESHOOTING – CALIBRATION FAIL**

### **STRENGTH LESS THAN 83%**

- ✓ Make sure standard containers (CAL1 and CAL2) are full of solution.
- ✓ Check that vapor bubbles are emerging from the bottom of the stainless steel entrainment tube.
- ✓ Check the condition of the reagent solution.
- ✓ Regenerate the sodium measuring electrode. See Section 5.5.2  
If the slope value is not improved after the sodium measuring electrode is regenerated, the electrode may need to be replaced.

### **STRENGTH MORE THAN 100%**

- ✓ Possible cause may be faulty reference electrode. Check status of reference electrode filling solution and add more if using N3010-171A.
- ✓ Check the status of reference electrode and replace if necessary.
- ✓ Make sure standard containers (CAL1 and CAL2) are full of solution.

### **VERY LOW OR 0% SLOPE**

- ✓ Check the operation of the solenoid valve(s).
- ✓ Check flow of standard solution through flow cell.
- ✓ Check the level of the salt bridge solution in the reference electrode, if using N3010-171A.
- ✓ Check for open circuit reference electrode by substituting it with an electrode of known performance.
- ✓ Check all electrical connections in the electrode junction box and interconnect cable.
- ✓ Make sure standard containers (CAL1 and CAL2) are full of solution.

## **5 MAINTENANCE**

### ***5.1 BUFFER SOLUTION(S)***

**⚠WARNING.** These buffers are mildly toxic and hazardous, and should be handled with care.

Two alternative reagent solutions may be used, depending on the required lower limit of measurement. Concentrated ammonia solution, which provides adjustment of sample pH to 10.7 is suitable for measurements of sodium ion to approximately 0.5ppb. At concentrations below 0.5ppb, hydrogen ion interference becomes significant and a



9031C

reagent of 50% diethylamine solution should be used. This adjusts the sample pH to 11.2 - 11.5 and enables measurements to be made to concentrations below 0.5ppb.

### **Concentrated Ammonia Solution - 1 liter**

**⚠WARNING.** This buffer should only be handled under a fume hood. It causes burns and is irritating to the eyes, respiratory system and skin. Wear rubber gloves and eye protection. In warm weather pressure increases in the bulk container of ammonia and the cap must be released with care.

Waltron L.L.C. uses a 28 - 30% w/v solution (0.89 s.g.) which is recommended. Refer to section 5.7 which relates to sodium concentration and pH.

**Note.** Waltron L.L.C. offers Ammonium Hydroxide in a 2.5 liter container. Part N1234-116.

### **Diethylamine Solution - 50%**

**⚠WARNING.** Diethylamine is an extremely flammable and irritating colorless liquid with a strong smell of ammonia. It should be handled with care at all times. The following points should also be noted:

Avoid breathing vapor and avoid contact with skin and eyes.

Work under a fume hood, wearing rubber gloves and eye protection.

In the event of a fire, extinguish with water spray, foam, dry powder or carbon dioxide.

If a spill occurs, shut off all possible sources of ignition, and instruct others to keep at a safe distance. Mop up spill with plenty of water, diluting greatly. Ventilate the area well to evaporate any remaining liquid and dispel vapor.

Effluent from the monitor contains diethylamine (if this buffer is used). Contact with it should also be avoided.



Put 500ml of high purity water into the buffer container and carefully add 500ml of analytical reagent grade diethylamine ( $C_2H_5)_2NH$ . Swirl the solution and allow it to cool to room temperature before fitting the container cap.

## 5.2 STANDARD SOLUTIONS

The following instructions refer to the preparation of 100ppb and 1ppm sodium, LOW and HIGH standard solutions respectively, but any concentrations can be prepared within the measuring range selected by appropriate dilution of the stock solution.

- ✓ Waltron L.L.C. offers Sodium Standard, 100 ppb, in a 5 gallon container. Part Number N1234-544.
- ✓ Waltron L.L.C also offers Sodium Standard, 1 ppm, in a 5 gallon container. Part Number N1234-545.

Dissolve 2.543( $\pm 0.001$ )g of analytical reagent grade sodium chloride in approximately 100ml high purity water. Transfer this solution to a one liter volumetric flask and make up to the 1 liter mark with more high purity water to give a stock solution of 1000ppm sodium ions. Store in a plastic container.

Pipette 10ml of this solution to a one liter volumetric flask. Make up to the 1 liter mark with high purity water to give a solution of 10ppm sodium ions.

Pipette 20ml of the 10ppm solution into a two liter volumetric flask and make up to the 2 liter mark with high purity water to give the LOW standard solution of 100ppb sodium ions. Transfer this solution to the bottle labeled Low Calibration Standard.

Transfer 200ml of the 10ppm solution into a two liter volumetric flask and make up to the 2 liter mark with high purity water to give the HIGH standard solution of 1ppm sodium ions. Transfer this solution to the bottle labeled High Calibration Standard.

- Do not prepare static sodium solutions of less than 50ppb because low concentration solutions rapidly become contaminated and change in concentration.
- Although the HIGH and LOW standard solutions are typically one decade apart in sodium concentration, any concentration difference can be used within the constraints of i) above and the need to have a significant change in electrode output to achieve an accurate calibration.



Note. High purity water is water containing less than 2ppb sodium ions and a specific conductivity of less than approximately 0.2 $\mu$ S/cm.

### 5.3 ETCHING SOLUTION

Note. Waltron L.L.C. offers the solution under our Part Number N1234-543, Sodium Electrode Regeneration Solution, 2 oz size.

For use on applications where the sample sodium concentration is below 1ppb - see also Section 5.5.2.

⊗WARNING. Sodium Fluoride is toxic. Avoid inhaling the dust and prevent contact with skin and eyes. Wear a dust mask, rubber gloves and eye protection. When prepared, the etching solution contains 0.1M Hydrofluoric acid (0.2% HF). Take care to prevent contact with skin and eyes.

Dissolve 5.0 ( $\pm$ 0.2)g analytical grade sodium fluoride, NaF, in approximately 400ml high purity water. Add to this solution 20 ( $\pm$ 0.2)ml 5M acetic acid\*, CH<sub>3</sub>COOH, and dilute to 1 liter.

Note: 5M acetic acid can be prepared from concentrated acid by adding 144 ( $\pm$ 1)ml analytical reagent grade glacial acetic acid (1.05 s.g.) to 500ml of high purity water.

⊗Warning: Prepare the acetic acid solution under a fume hood and take the appropriate precautions when handling concentrated acids.



#### **5.4 REFERENCE ELECTRODE FILL SOLUTION** *(For Use with N3010-171A)*

Waltron L.L.C. offers a stock solution of 3.0 M Potassium Chloride in a 2oz. size. Part Number N1234-547.

This solution is required for refilling the calomel reference electrode at extended intervals. This solution should be stored in a tightly sealed plastic bottle. The electrode is most conveniently filled using the supplied eyedropper or a syringe.

#### **5.5 SCHEDULED SERVICING**

The following procedures are guides to the maintenance requirements of the monitor. The procedure chosen depends on the particular installation and sample conditions.

##### **5.5.1 WEEKLY**

If the monitor is continuously running at high concentrations, greater than 100ppb, a weekly Single Point Calibration is recommended. See Section 3.7.1 Single Point Calibration.

##### **5.5.2 MONTHLY**

- Replace the bottle of reagent buffer solution. The level of solution should not be allowed to fall below about three-quarters full. On high ambient temperature installations and for low sodium concentrations, the solution may require replacement more frequently.
- Check the level of reference electrode filling solution; refill as required.
- It is recommended you calibrate once a month
- The following procedures should be carried out:

When the sodium concentration is above 1ppb, carry out a Two Point Calibration - see Section 3.7.2; note the slope value.

#### **Sodium Measuring Electrode Etching/Regeneration Instructions:**

When the sodium concentration is below 1ppb, apply the following regeneration/etch procedure before carrying out a Two Point Calibration:

**Note.** When used for prolonged periods at low concentrations, leeching of sodium ions from the electrode surface accelerates the aging process of the electrode which is shown by poor response time, low slope value and a limitation to respond to low levels. Calibration may then be in error because of slow response and poor reproducibility. The reactivation procedure minimizes problems from these sources.  
**Also:** Etching is not for new probes, it is part of the monthly maintenance procedure

- Remove the sodium electrode from the flowcell and slide off the sleeve and 'O' ring; it is not necessary to detach the electrode lead.
- Prepare two plastic beakers, one containing about 50ml of etching solution, the other about 200ml high purity water.
- Dip the electrode in the etching solution for 60 ( $\pm 5$ ) seconds; then rinse in high purity water.

 **Caution.** It is important not to exceed the etching time or the performance of the electrode may be permanently degraded.

- Dispose of the etching solution by diluting to waste with plenty of water. Use fresh etching solution each time.

Fit the 'O' ring and sleeve and return the electrode to the flowcell. Prior to performing a calibration, run the monitor for one to two hours on low level sodium sample. No further calibration should be needed until the next reactivation procedure.

This procedure must be carried out at regular monthly intervals and the process started as soon as a new electrode is put into service.

**Note.** It is extremely difficult to recover an 'old' electrode.

As the buffer solution, is replaced monthly, the following procedure should be carried out 24 hours after replenishment to allow pH stability to be achieved.

This procedure applies to both ammonia and amine buffered systems.

## **5.6 SHUT-DOWN PROCEDURE (Prolonged Shut-Down, 1+ months)**

1. Close the sample valve upstream of the monitor.



2. Remove the buffer container and safely dispose of the solution. Rinse the containers thoroughly.

⚠ **WARNING.** For safe handling instructions of buffer solutions refer to Chapter 6.

3. Fill the CAL1 calibration solution container with high purity water and do a single point calibration to flush the system.
4. Remove the electrodes and follow procedure in Section 5.6.1.
5. Use a syringe to flush all tubing with high purity water. This removes any particulate deposits.
6. Switch off the main power supply to the Transmitter Unit.

### 5.6.1 STORAGE OF ELECTRODES

Fill the rubber teat, supplied with the **sodium electrode**, with 5M sodium solution. Push the teat over the end of the electrode. For storing the refillable reference electrodes, fill the rubber teat with the refillable solution and push teat onto the end of the electrode. Refit the filling hole plug to seal the refill aperture. For storing the Gel-filled reference electrode, fill the rubber teat with a dilute KCl solution and push teat over the end of the electrode.

**Note.** Do not let either electrode dry out!!!

### 5.7 pH EFFECTS

Measuring the pH of the effluent from the flowcell indicates adequate buffering. The minimum pH depends on the minimum sodium concentration, but the pH value is calculated as:

pH must be greater than  $pNa + 3$ , so ideally at:

- 100ppb Na+, the pH must be greater than 8.4
- 10ppb Na+, the pH must be greater than 9.4
- 1ppb Na+, the pH must be greater than 10.4
- 0.5ppb Na+, the pH must be greater than 11.4

**Note.** If the buffer is allowed to become completely exhausted, the reading may be very erratic due to the lack of ionic strength adjustment of the high purity sample.



## 6 SPARE PARTS

### Recommended Spare Parts

<b>PART NUMBER</b>	<b>DESCRIPTION</b>
N3010-168	Electrode, Measuring
N3010-171A	Electrode, Reference
N3010-172	Electrode, Reference, Gel-filled
N3500-322	Kit, Re-tubing & O-Ring
N1234-543	Sodium Electrode Regeneration Solution (2 fl.oz.)
N1234-547	3.5 M KCL Reference Electrode Filling Solution
N1234-112	Sodium Standard 100 ppb, 1 gallon
N1234-113	Sodium Standard 1000ppb, 1 gallon
N1234-116	29% Ammonium Hydroxide (2.5 L)
N1142-149C	LOW Standard Calibration Bottle
N1142-150C	HIGH Standard Calibration Bottle
N3500-323	Sodium Expendable Kit

### Additional Spare Parts

<b>PART NUMBER</b>	<b>DESCRIPTION</b>
N1234-579	99% Di-Isopropylamine (1 Gallon)
N3010-170C	Thermistor, Flow Cell
N2554-064B	Flow Cell Complete Assembly (Less Electrode)
N2554-065B	Constant Head Unit Assembly
N1234-544	Sodium Standard, 100 ppb (5 gal.)
N1234-545	Sodium Standard, 1000 ppb (5 gal.) - (1 ppm)
N1053-106A	Earthing Tube
K1152-200	Nupro Filter, Stainless Steel, 60 Micron
P2000-022	Pre-Amp w/Junction Box, 9031C, Complete
N2554-066A	Entrainment "T" Assembly
P1000-017	CPU card
P1000-010	LCD Display
P1000-059	AC Power Terminal Box, 9001
N2552-098B	Solenoid Valve Assembly
N1152-169	Pressure Relief Valve
N2554-067A	Heat Exchanger Assy, 9031C
N3500-067	Sodium Standard (1 liter 100 ppm)
940-0000-00	Analog Board
907-0000-00	Crimp Terminal Kit





## 7 TROUBLE-SHOOTING

<b>Problem</b>	<b>Possible Cause(s)</b>	<b>Solution(s)</b>
Calibration Fail (CF)	Empty or Contaminated Standards Solutions Container(s)	Check to make sure CAL standard bottle is full, check CAL tubing to make sure it is not pinched. Replace CAL standard with fresh solution and try again.
Calibration Fail (CF)	Faulty Solenoid Valve	Run Solenoid Check cycle in Diagnostics – check status and connections of solenoid valve.
Calibration Fail (CF)	Strength is too low. <83	Make sure containers of standard (CA1 & CA2) are full of solution.
Calibration Fail (CF)	Strength is too low. <83	Verify condition of reagent solution. Replace monthly.
Calibration Fail (CF)	Strength is too low. <83	Verify electrodes are connected properly
Calibration Fail (CF)	Strength is too low. <83	Check that vapor bubbles are emerging from bottom of entrainment tube.
Calibration Fail (CF)	Strength is too low. <83	Ensure reference electrode tip is 42-48 mm from the top of the flowcell (5 mm into the sample)
Calibration Fail (CF)	Strength is too low. <83	Ensure calibration standard is flowing. Perform Solenoid Check cycle in Diagnostics to verify.
Calibration Fail (CF)	Strength is too low. <83	Regenerate the sodium measuring electrode. See section 5.5.2 in manual.
Calibration Fail (CF)	Strength is too high. >110	Make sure both containers of standard (CA1 & CA2) are full of solution.
Calibration Fail (CF)	Strength is too high. >110	Check level of reference electrode salt bridge solution; add more if necessary
Calibration Fail (CF)	Strength is too high. >110	Faulty reference electrode. Replace with one of known performance.
Calibration Fail (CF)	Strength is close to zero.	Make sure both containers



		of standard (CA1 & CA2) are full of solution.
Calibration Fail (CF)	Strength is close to zero.	Ensure there is flow of standard solution through flow cell.
Calibration Fail (CF)	Strength is close to zero.	Check all connections in electrode junction box and interconnect cable.
Calibration Fail (CF)	Strength is close to zero.	Verify operation of solenoid valve.
Calibration Fail (CF)	Strength is close to zero.	Check level of salt bridge solution in reference electrode.
Calibration Fail (CF)	Strength is close to zero.	Faulty reference electrode. Replace with one of known performance.
Calibration Fail (CF)	No standard flow.	Check for clogs in system. Check for air trapped in tubing. Elevate standard container or temporarily disconnect tubing to solenoid to facilitate flow of standard through tubing to valve. Reconnect once standard is flowing. Filter sample if deposits found in analyzer tubing.
Readings are not accurate – too low.	Old/bad reagent. Poor electrode performance. Bad calibration.	Replace reagent solution. Regenerate/replace sodium measuring electrode, refill/replace reference electrode. Check CAL log and run another CAL if results are not good.
Readings are not accurate – too high.	Poor electrode performance. Bad calibration. Sodium leak in sample system.	Regenerate/replace sodium measuring electrode, refill/replace reference electrode. Check CAL log and run another CAL if last result is not good.
Readings are not accurate – erratic	Exhausted reagent	Replace reagent. Recommended monthly
Current outputs (4-20mA) not functioning correctly.	Disconnected wiring at transmitter or along wire path. DCS/recording	Check output set-up to make sure values are entered properly. Run



	system not set up properly. Bad CPU board.	Diagnostics – O/Pma Check cycle and check output coming directly from transmitter. Replace CPU board if output is not correct.
Alarms not functioning correctly.	Disconnected wiring at transmitter or along wire path. DCS/recording system not set up properly. Bad DIO board.	Check alarm set-up to make sure values are entered properly. Run Diagnostics – Relay Check cycle and check alarm output directly from transmitter. Replace DIO board if output is not correct.
Display read “HOT”	Sample temperature over specified range (>131F). Faulty thermistor.	Check sample temperature. Clean/replace thermistor.
Display read “TEMP”	No thermistor response.	Clean/replace thermistor. Check thermistor connection at pre-amp.
Display read “OVR”	Signal from electrodes too high – sample concentration over maximum range (>10ppm)	Check sample concentration. Check electrode connections at junction box and pre-amp.



## 8 SPECIFICATIONS

Range:	0.01ppb – 10ppm
Accuracy:	+/-5% of reading or +/- 0.1ppb (whichever is greater) within +/- 5C of calibration temperature
Reproducibility:	+/-5% of reading or +/- 0.1ppb (whichever is greater) at constant temperature
Response Time:	90% of 1-10ppb step: less than 4 minutes; 90% of 100-1ppm step: less than 6 minutes
Current Outputs:	Two isolated 4-20mA current (analog) outputs
Alarms:	Three voltage-free contacts, alarm points set from transmitter rated at 2A, 250VAC (non-inductive)
Power:	Wide range of input power supply 90VAC – 250VAC
Sample:	Temperature: 41-131F (5-55C); Flow 150-400ml/min
Ambient Temp:	32-131F (0-55C)
Pressure:	5-30psig
Composition:	Sample should be filtered to 60 microns, free of film forming compounds
Power Consumption:	Less than 20VA
Sample Inlet Fitting:	1/8 NPT Swagelok
Sample Outlet Fitting:	Nozzle that fits 3/8" hose connection



## 9 APPENDIX 9031C

This appendix is to be used as a reference. The information provided here is theoretical.

Sodium Concentration	Theoretical Preamp Input (mV)
0.01 ppb	-476.63
0.02 ppb	-458.82
0.05 ppb	-435.27
0.1 ppb	-417.47
0.2 ppb	-399.66
0.5 ppb	-377.11
1 ppb	-358.31
2 ppb	-340.5
5 ppb	-316.95
10 ppb	-299.15
20 ppb	-281.34
50 ppb	-257.79
100 ppb	-239.99
200 ppb	-222.18
500 ppb	-198.63
1 ppm	-180.83
2 ppm	-163.02
5 ppm	-139.47
10ppm	-121.67

Approximate electrode mV outputs for calibrations using Waltron Electrodes:

Refillable Reference Electrode		Gel-Filled Reference Electrode	
mV 1 (100 ppb)	mV 2 (1 ppm)	mV 1 (100 ppb)	mV 2 (1 ppm)
240-260 mV	180-200 mV	240-260 mV	180-200 mV

## 10 APPENDIX Panel Mount

This Appendix shows the schematics of the Panel Mount Bracket option for the transmitter case.

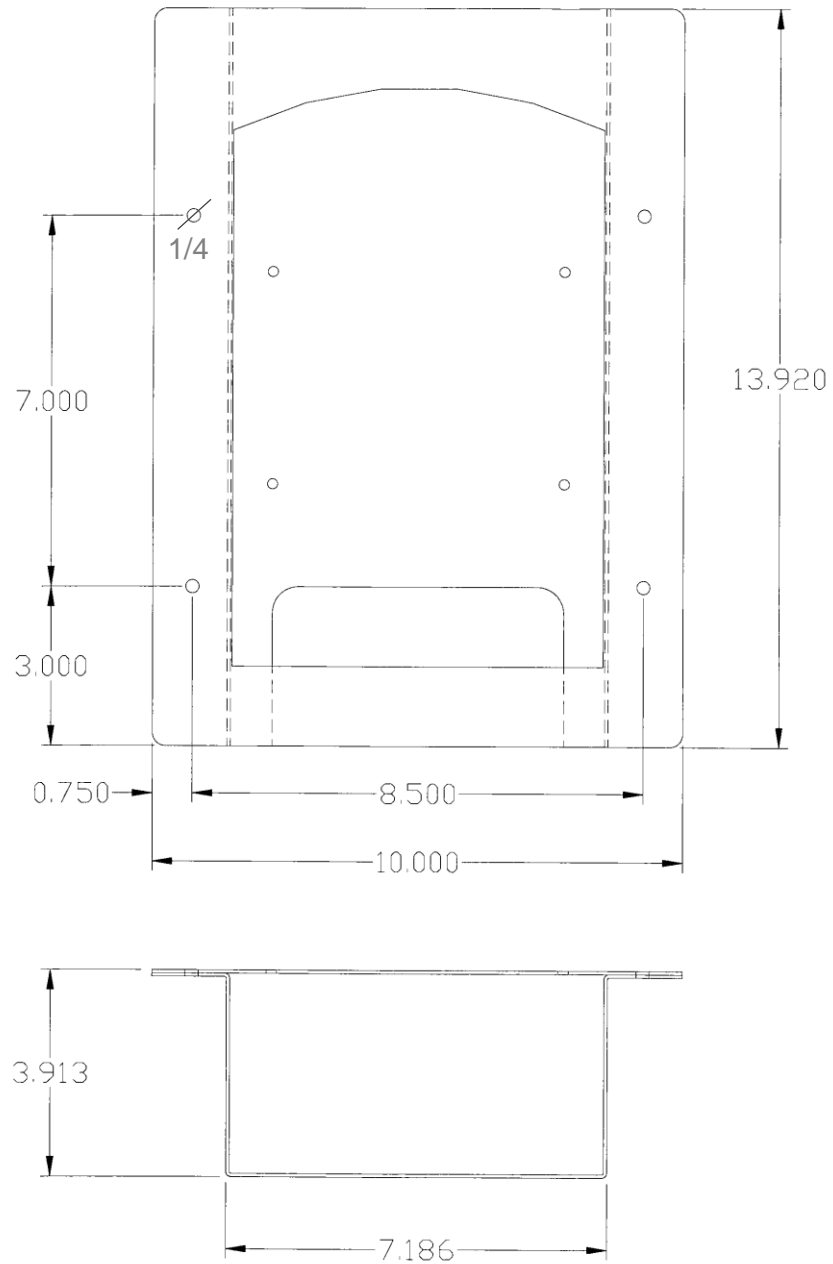

## 11 APPENDIX Instructions for Crimping Terminals

### 11.1 *Crimping Terminal onto Wire Ends*

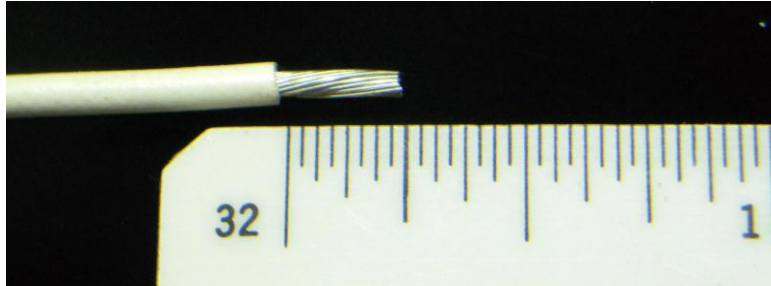

**Figure 1:** Strip the wire to approximately 0.25in. Ideally, use at least 20AWG wire but your wire terminal kit will accommodate gauges from 22-10AWG.

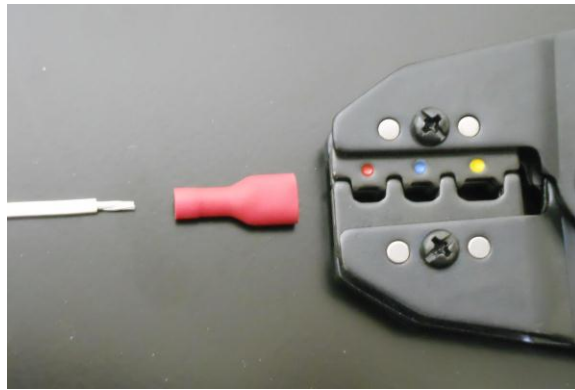

**Figure 2:** Select the appropriate terminal based on the wire gauge used. Red-colored terminals handle 22-18AWG; blue terminals are for 16-14AWG and yellow are for 12-10AWG. Note the corresponding color dots on the crimp tool die set. Match the terminal to the position on the die. Do not over-crimp by using a smaller die position for the terminal – you will damage the wire strands and wind up with a weak connection.

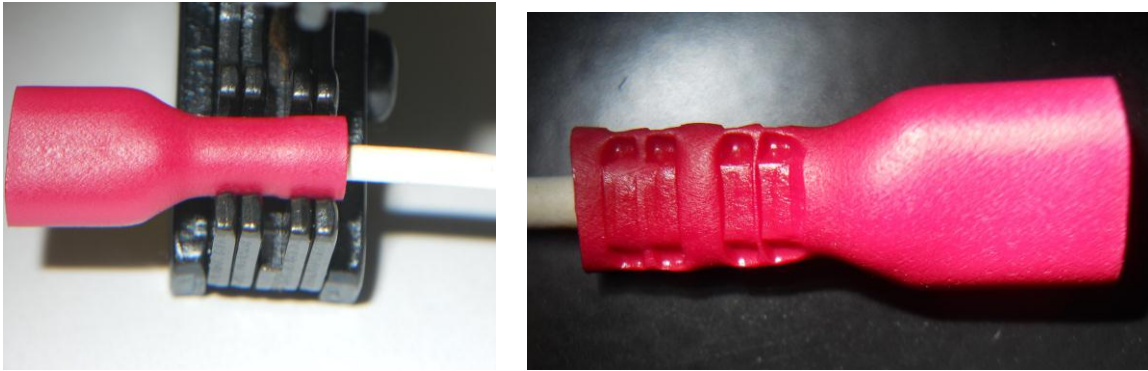

**Figure 3A:** Position the terminal in the die, as shown at the left. It is important to have the terminal positioned so that the connector end of the terminal is even with the jaw and the crimp part of the terminal mates correctly with the crimp tool die.

**Figure 3B:** If done correctly, the crimped terminal should appear as in the photo at the right. The die was centered in the crimp area and there is a good dual crimp made on that part of the terminal.

Note that there are actually two crimping actions – one to make the electrical connection (the rightmost pinch) and one to make a mechanical strain relief (the leftmost pinch). Take the time to seat the terminal in the die accurately. If the terminal twists or shifts on the die, reposition it before executing the crimp.



## 11.2 Attachment of Terminated Wires to the Analog Board

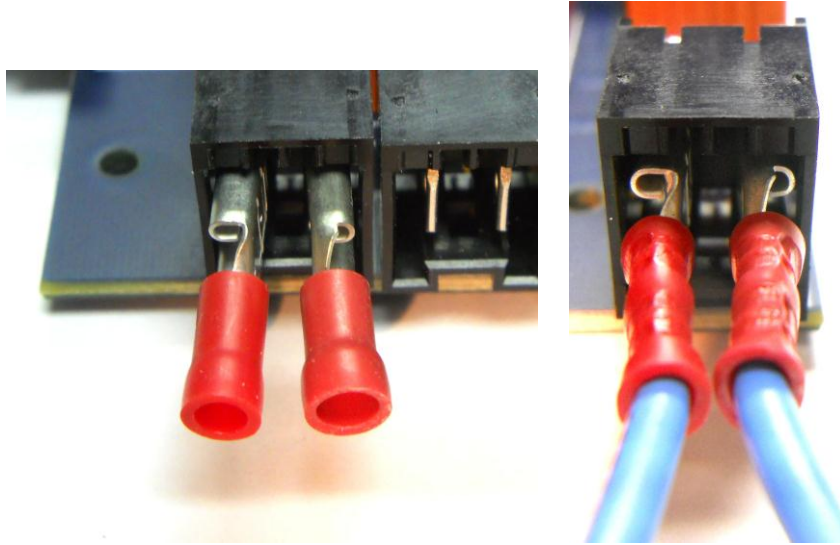

**Figure 4A:** Only partially shrouded terminals will fit onto the Analog Board's connectors. An assortment of suitable connectors and a crimp tool is supplied in Waltron's Terminal Kit, p/n 907-0000-00. Note that the orientation of the terminals is important to maintain maximum electrical separation. Position the connectors facing in the directions shown before fully inserting.

**Figure 4B:** Here is a completed wire termination to the Analog Board. The wires are mechanically secured in the terminals by the crimp tool action and the terminals are positively mechanically secured by a dimple in the board connector mating to a similar dimple in the crimp terminal. For this reason, Waltron only recommends using TE Connectivity (AMP) terminals when terminating to the Analog Board.