



EXPERTS IN WATER CHEMISTRY SINCE 1903



# **Waltron Aqualert 6051 Hardness Analyzer Instruction Manual**



## WALTRON CUSTOMER COMMITMENT

This instruction manual is a technical guide to aid the customer in the set-up, operation, and maintenance of their new Waltron measuring system. Waltron provides continuous product improvement and reserves the right to make any modifications to the information contained herein without notice.

*Copyright © Waltron Bull & Roberts, LLC, 2023  
All Rights Reserved*

Technical questions concerning this product should be addressed to:

**Waltron Technical Service Department**  
Flemington, New Jersey  
**Phone:** (908)-534-5100  
**Fax:** (908)-534-5546  
[www.waltron.net](http://www.waltron.net)

Please be ready to provide the following information:

- Date analyzer was purchased
- Analyzer model and serial number
- Recent maintenance history
- Calibration slope values and detailed description of problem

Waltron's technical expertise and extensive experience provides personalized solutions to the water quality industry. It is Waltron's commitment to provide the customer with timely and accurate technical service and support.

Waltron fully expects the customer to be satisfied with the quality, performance, and cost of this product.

If there are any questions or concerns regarding this product, please feel free to contact Waltron at (908)-534-5100.

**Thank you for choosing Waltron!**

Please note the Waltron mailing and shipping address:

Waltron Bull & Roberts, LLC  
25 Minneakoning Road, Suite 101  
Flemington, NJ 08822



## SAFETY

Please observe proper safety and handling precautions when installing, operating, maintaining, and servicing this product. The following should be noted and adhered to:

- Read and understand manual before working with analyzer.
- Pay special attention to warning labels on enclosures, containers, packages and chemicals.
- Only qualified personnel should be involved in the installation, operation, and servicing of the analyzer.
- Follow safety precautions when operating analyzer in conditions of high pressure and/or temperature.
- Keep analyzer chemicals away from heat and extreme temperatures. Reagent powders must be kept dry.
- Follow all regulations and warning labels when disposing of chemicals. Do not mix chemicals.

To obtain analyzer safety information or Safety Data Sheets (SDS), please contact Waltron or logon to [www.waltron.net](http://www.waltron.net).



## WARRANTY AGREEMENT

If, within one year from the date of shipment, the customer experiences any equipment defects or is not satisfied with the analyzer manufacturing, Waltron will repair, or at its option, replace any defective part(s) free of charge. This warranty requires that the defective part(s) be returned to Waltron with shipping charges prepaid.

At Waltron discretion, a Technical Service Specialist may be sent out to repair or replace the defective part(s) on location. Traveling time and expenses of the Technical Service Specialist is at the customer's expense.

Equipment sent to Waltron must be appropriately packaged and the following information must be provided prior to returning to Waltron:

- The Return Authorization (RA) number assigned to the customer by the Waltron Technical Service Department
- Customer name, address and department
- Name and telephone number of the individual responsible for returning items for repair
- Brief problem description

### **Ship to Waltron service center:**

Waltron Bull & Roberts, LLC  
25 Minneakoning Road, Suite 101  
Flemington, NJ 08822

### **The Waltron Warranty Agreement:**

- Covers expendable sensors for one month after shipment and reusable electrodes for six months after shipment.
- Does not apply to damages occurred during shipping.
- Warranty will be nullified if goods have been used for purposes other than those for which they are intended or if any seal has been removed, broken or tampered with or if the Waltron trademark or serial number has been removed, defaced, or altered.
- Does not cover expendable supply items such as reagents, tubing and electrolytes.
- Does not cover misuse or mistreatment by the user.
- Does not cover previous repair or alteration by unauthorized individuals.

Waltron does not assume responsibility for contingent liability through alleged failure or failures of products or product accessories.



## CHECKLIST OF MATERIALS

- In order to ensure customer satisfaction, Waltron does its best to provide adequate and timely packaging and shipping services. Please perform the following after receiving a shipment:
- Inspect all shipping containers upon receipt and record any visible damage. If there are any outward signs of damage, please retain all containers and packages for inspection by carrier. Please retain all packing material so that it can be used for future moving and shipping needs.
- Check all items received against those on the packing list. Chemicals are usually shipped in a separate package and will be itemized accordingly.
- Verify that the number of packages received agrees with the packing list and shipping papers.
- Notify both Waltron and the carrier if any problems occur.

### **Important Notice:**

- All analyzers are inspected and tested prior to shipment.
- In normal use, the unit should require only minor maintenance and should operate correctly and without fault over a long period of time.
- Please note that if electronic components need to be replaced, it may be necessary to adjust and/or calibrate the analyzer.
- Failure to carry out correct maintenance procedures may result in inaccurate analyzer readings.

## Table of Contents

<b>WALTRON CUSTOMER COMMITMENT .....</b>	<b>2</b>
<b>SAFETY .....</b>	<b>3</b>
<b>WARRANTY AGREEMENT .....</b>	<b>4</b>
<b>CHECKLIST OF MATERIALS .....</b>	<b>5</b>
<b>1 INTRODUCTION.....</b>	<b>8</b>
<b>2 UNIT DESCRIPTION.....</b>	<b>10</b>
2.1 PRINCIPLE OF FUNCTION .....	10
2.2 UNIT OVERVIEW .....	10
2.3 SCOPE OF DELIVERY .....	11
2.4 SPECIFICATIONS AND AREAS OF APPLICATION .....	12
2.5 BOB-OPERATION .....	15
2.6 INSTALLATION REQUIREMENTS .....	15
2.7 MAINTENANCE SETS.....	17
<b>3 GENERAL SAFETY .....</b>	<b>18</b>
<b>4 INSTALLATION .....</b>	<b>22</b>
4.1 WALL MOUNTING WITHOUT CASE .....	22
4.2 WALL MOUNTING WITH CASE.....	22
4.3 WATER CONNECTIONS.....	23
4.4 OPERATING WITH PRESSURE-LESS SAMPLE WATER.....	24
<b>5 ELECTRICAL INSTALLATION .....</b>	<b>25</b>
5.1 CONNECTING THE SUPPLY VOLTAGE .....	26
5.2 CONNECTION OF THE RELAY OUTPUTS .....	27
5.3 CONNECTING THE ANALOG OUTPUTS .....	28
5.4 CONNECTING THE DIGITAL INPUTS .....	29
<b>6 CONNECTING THE EXTERNAL COMPONENTS .....</b>	<b>30</b>
6.1 CONNECTING THE EXTERNAL COMPONENTS.....	30
6.2 SWITCH FOR STARTING THE ANALYSIS EXTERNALLY.....	31
6.3 FLOW SWITCH .....	32
6.4 INTERVAL RESET .....	33
6.5 REAGENT LIGHT/HORN.....	34
6.6 REGENERATION SYSTEM FOR DEMAND-CONTROLLED REGENERATION TRIGGERING .....	35
6.7 ANALOGUE MEASURING DEVICE.....	35
6.8 OPERATING STATUS VIA ANALOGUE CURRENT INTERFACE.....	37
<b>7 COMPONENTS AND OPERATION.....</b>	<b>38</b>
7.1 LOCATION OF COMPONENTS.....	38



---

7.2	DISPLAY AND KEYBOARD.....	39
<b>8</b>	<b>CONFIGURATION .....</b>	<b>45</b>
8.1	FACTORY SETTINGS .....	45
8.2	CONFIGURATION ASSISTANT .....	45
<b>9</b>	<b>OPERATION .....</b>	<b>54</b>
9.1	MODE .....	54
9.2	MAIN MENU .....	54
9.3	MAINTENANCE FUNCTIONS.....	55
9.4	ACTION IN EVENT OF POWER LOSS.....	55
9.5	SD-CARD .....	55
9.6	MENU STRUCTURE .....	57
<b>10</b>	<b>MAINTENANCE AND SERVICE.....</b>	<b>58</b>
10.1	CLEANING THE MEASURING CHAMBER.....	58
10.2	INSERTING THE "MAINTENANCE SET 02" .....	59
10.3	RESET THE MAINTENANCE COUNTER .....	61
10.4	CHANGING THE REAGENT BOTTLE .....	62
10.5	GOOD AND BAD COUNTER .....	62
10.6	CALIBRATING THE UNIT .....	63
10.7	CHANGING THE BATTERY .....	64
10.8	SOFTWARE UPDATE .....	64
<b>11</b>	<b>DIAGNOSTICS.....</b>	<b>65</b>
11.1	DISPLAY .....	65
11.2	SENSOR .....	65
11.3	SOLENOID VALVE.....	65
11.4	REAGENT PUMP .....	66
11.5	AGITATOR BLADE.....	66
11.6	RELAY 1 AND 2.....	66
11.7	CURRENT INTERFACE .....	66
11.8	INPUT.....	67
<b>12</b>	<b>ERROR ANALYSIS .....</b>	<b>68</b>
12.1	ERROR MESSAGES .....	68
12.2	FAULT FINDING.....	69
<b>13</b>	<b>SPARE PARTS .....</b>	<b>71</b>
<b>14</b>	<b>MAINTENANCE SETS .....</b>	<b>73</b>
<b>15</b>	<b>MEASUREMENT RANGE OF OUR REAGENTS .....</b>	<b>74</b>
<b>16</b>	<b>CALCULATION TABLE FOR COMMON UNITS OF WATER HARDNESS .....</b>	<b>75</b>
<b>17</b>	<b>INSTRUCTIONS FOR DISPOSAL .....</b>	<b>76</b>

## 1 Introduction

Thank you for buying the **analyzer** from the product range of on-line water quality monitors.

The **analyzer** belongs to the most modern systems on the market and sets new standards:

- Simple to operate
- Quick commissioning via menu
- Easy maintenance and cleaning
- Intelligent measuring-chamber design
- High measuring accuracy
- Self-calibrating

The **analyzer** for the monitoring of water quality is part of a water preparation system. This handbook is tailored for both the manufacturers and the operators of such equipment.

This handbook contains instructions for the use and operation of the **analyzer**. Please read these instructions carefully before operating the unit.

We recommend that this handbook is kept near the unit for quick reference although we have made every effort to make the unit, as far as possible, self-explanatory in its operation.

The unit should only be operated in harmony with the instructions in this handbook.

We will not accept any liability for damage caused by operator error or failure to follow the instructions found in this handbook.

**Some details and instructions in this handbook may vary slightly from the delivered unit. We reserve the right to make technical changes to improve our products without prior notice.**

The **analyzer** from the product range is an on-line analyzer that automatically recognises and warns of the increase in water hardness in a water preparation system. When used with a water grading system, the professional monitors can control the minimum and the maximum hardness (for drinking water for example).

**This is not a system to prevent increase in water hardness.**

- ✓ Reliable, exact and fully automatic analyzing unit with matching reagents for measuring the total hardness in the range 0.02-30 °dH (3.6- 5349 µmol/l) as well as carbonate hardness in the range 0.3 – 9 °dH (53.5 – 1605 µmol/l)
- ✓ Measurement of all parameters with one sensor.
- ✓ Simple commissioning with configuration assistant.
- ✓ BOB-Operation(72h)-salt boiler
- ✓ Self-calibrating and self-monitoring
- ✓ High measuring accuracy
- ✓ Easy maintenance and cleaning.
- ✓ Compact design 300x300x140mm.
- ✓ Multi-coloured and multi-lingual graphic display.
- ✓ Relay output for limit value.
- ✓ Relay output for error message.
- ✓ 1 analogue output 0/4-20mA.
- ✓ 1 digital input for start analysis, flow switch, or interval reset.
- ✓ Measurement data storage.

Diverse programmable alarm functions

- ✓ Connection possibilities for: water-meters; turbines; pre-coolers; rinsing valves
- ✓ External operation by means of external controller
- ✓ Many programmable functions for the inputs and outputs
- ✓ Monitoring of 2 limit values
- ✓ No condensation
- ✓ CAN- interface
- ✓ Software updates by means of SD-card possible
- ✓ Open wall mounting or wall mounting in protective casing (optional)
- ✓ Supply voltage 85 - 305 VAC, 47 – 440 Hz

## 2 Unit description

The on-line hardness monitor **analyzer** is a compact analysis unit which is able to monitor the presents of various chemicals in water. In these instructions, only the on-line monitoring of total hardness and carbonate hardness are described.

### 2.1 Principle of Function

The **6051** is an on-line analyzer for the automatic investigation of water parameters by the colorimetric test method. Following the introduction of a reagent into the water sample, a colour reaction occurs. Depending on the chosen method, the unit either evaluates the *intensity* of the colour or ascertains the *value* at which the colour changes. From this information the **analyzer** calculates the concentration of the chemical content. The unit can only ascertain one parameter. The method and the measurement range are determined by the reagent.

### 2.2 Unit overview

The **analyzer** has two variations:

#### 1. Analysis unit on wall mounting

The Analysis unit consists of a control unit and a measuring chamber. Both are mounted on a wall mounting plate. This variation is completely functional and includes the connections for the water inlets and outlets as well as the holder for the reagent bottle. (Fig. 1)

#### 2. Analysis unit in protective case

In addition an optional plastic case is available to protect the unit in environments where extreme levels of dirt and grease are expected. (Fig. 2)The Analysis unit on the wall mounting plate is easily fixed in the protective case by 4 screws. If the analysis unit and the protective case are ordered together, they will be delivered assembled.

The analysis unit is operated by means of a menu, a graphic display and 6 keys on the control panel.

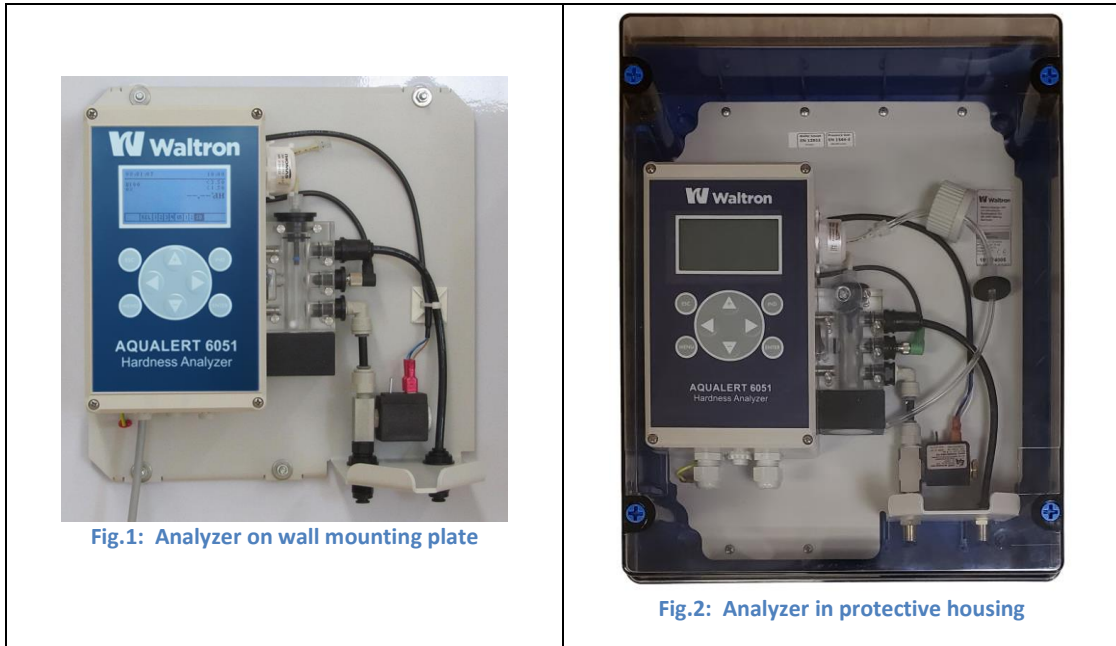

**Fig.1: Analyzer on wall mounting plate**

**Fig.2: Analyzer in protective housing**

<b>Description</b>
<b>analyzer on wall mounting plate</b>
<b>analyzer complete with housing</b>

### 2.3 Scope of delivery

The analyzer is delivered completely pre-configured and ready for connection. Before installation, please check that all components are present and correct.

If you receive the analyzer on a mounting plate, you will receive the following components:

<b>Description</b>
<b>analyzer Basic unit on mounting plate or analyzer with housing</b>
<b>Accessory kit with bottle connector</b>
<b>Operating Instructions (Italian, English or German)</b>

## 2.4 Specifications and Areas of application

### General Specification

<b>Supply Voltage</b>	<b>85-305 VAC (47-440 Hz)</b>	
<b>Power consumption</b>	24 VA (in operation)	3.5 VA (standby)
<b>Protection class</b>	Open wall mounting	IP43
	Mounting in case	IP 56
<b>Environmental temperature</b>	10°C – 40°C	
<b>Measuring water temperature</b>	5°C – 40°C	
<b>Humidity</b>	20 -90 % RF (without ice or condensation)	
<b>Water inlet pressure</b>	ca. 0.5 - 5 bar (max.) (Recommended 1 - 2 bar)	
<b>Water inlet in general</b>	clear, colourless, free of solid particles, without gas bubbles	
<b>Requirements of the water quality during measurement of the water hardness</b>	pH:	4 – 10
	Iron:	< 3 ppm
	Copper:	< 0.2 ppm,
	Aluminium:	< 0.1 ppm
	Manganese:	< 0.2 ppm
	Acid capacity:	KS4.3 < 5mmol/l

### Technical Data

<b>Installation</b>	<b>Wall mounting in closed rooms</b>	
<b>Dimensions</b>	Without case:	280x360x114 mm (WxHxD)
	With case:	300x380x120 mm (WxHxD)
<b>Weight</b>	Without case:	ca. 2.1 kg
	With case:	ca. 4.0 kg

## Analysis Qualities

<b>Measurement method</b>	<b>Titration method with colour change</b>		
<b>Measurement range</b>		Total Hardness	Carbonate Hardness
	ppm CaCO <sub>3</sub>	0,21 ... 535,7	5,4 ... 401,8
	°dH	0,012 ... 30	0,3 ... 22,5
	°f	0,021 ... 53,6	0,5 ... 40,2
	°e	0,015 ... 38,6	0,39 ... 28,9
	mmol/l	0,0021 ... 5,36	0,11 ... 8,04
	The measuring range is defined by the reagent used. The entire measuring range of the total hardness is achieved by using different reagents.		
<b>Accuracy</b>	<p>Measurement accuracy:</p> <p>+/- 5% of the upper value of the respective reagent (see page 74.)</p> <p>Repetition accuracy:</p> <p>+/- 2.5% of the upper value of the respective.</p> <p>Please note: The accuracy of the measurements may be adversely affected by the impurity of the water. In such cases, we recommend that you take a hardness measurement by hand titration and then calibrate the analysis unit to this value.</p>		
<b>Reagent consumption</b>	ca. 0.05-0.5 ml/ analysis depending on the hardness of the water		
<b>Measurement duration</b>	ca. 3 minutes depending on the hardness of the water		
<b>Number of analyses</b>	ca. 10,000 analyses / 500 ml reagent by low hardness. The consumption is dependent on the measured water hardness and the reagent used.		
<b>Expiration date of the reagent</b>	At least 2 years		
<b>Water consumption</b>	<p>ca. 1l/analysis at 2 bar</p> <p>The water consumption varies according to pressure and flush-time.</p>		



## Inputs / Outputs

<b>2 Relay outputs</b>	Max. 250 VAC 1 A as potential free output NC/NO the relays offer the following functions: <ul style="list-style-type: none"><li>• Limit alarm</li><li>• Device error</li><li>• Standby</li></ul>
<b>Signal input</b>	Electrically separated contact input <ul style="list-style-type: none"><li>• Start analysis</li><li>• Flow Switch</li><li>• Interval rest</li></ul>
<b>AnalogueOutput</b>	0 – 20 mA / 4 – 20 mA Resolution: < 100 $\mu$ A Max. working resistance: 750 $\Omega$

## Maintenance Intervals

<b>Every 6 months</b>	Cleaning of the measurement chamber  (At high ambient and water temperature or water with high organic load, the cleaning intervals may need to be shortened).
<b>Every 30,000 Analyses or after 2 years of operation</b>	Cleaning of measurement chamber (as above), Installation of maintenance kit: changing the peristaltic pump cartridge and the gaskets.

## 2.5 BOB-Operation

The abbreviation BOB stands for “Betrieb ohne Beobachtung”(which means “Operation without Observation”). This a special term found in the German ‘TÜV’ rules for boiler-houses. These rules require that an analysis unit has enough reagent to last for 72 hours for unmanned operation.

A relay output can be used, for example to activate an alarm if the reagent level is below that necessary for the minimum time interval.

The analysis unit is specially designed for ,BOB’-operation. Boiler systems require an accurate monitoring of water quality, especially the hardness of the boiler supply water according to the technical guide-lines for boiler systems TRD 604 (Technische Regeln für Dampfkessel, published by the ‘TÜV’).

The analysis unit calculates the consumption of reagent to make sure that enough reagent is available for reliable measurements during the period of unobserved operation.

If the next 72 hour ‘BOB’-operation cannot be reliably guaranteed, the alarm “Reagent shortage” will be activated. Please check to see that the reagent is within its best before date. Only use fresh reagent.

## 2.6 Installation requirements

### Reagents / Maintenance sets / Accessories

There are various analyzer reagents available that cover a wide range of measurement. When choosing the correct reagent, it is important that the hardness range to be monitored lies in the middle of the measurement range of the reagent.

In all, the analyzer covers the measurement range of 3.6 - 5349  $\mu\text{mol/l}$ . There are 11 reagents available:



The order numbers of the reagents (500ml) are shown in the following table.

<b>Total Hardness</b>		
W1234-455	500S/500	0.22-2.14ppm / 0,02-0,12°dH / 0,04-0,21°f
W1234-456	500/500	0.36-3.56ppm / 0,02-0,2 °dH / 0,04 - 0,36°f
W1234-457	501/500	0.53-5.34ppm / 0,03-0,3°dH / 0,05-0,54°f
W1234-458	502/500	1.07-10.68ppm / 0,06-0,6°dH / 0,11-1,07°f
W1234-459	503/500	1.60-16.02ppm / 0,09-0,9°dH / 0,16-1,61°f
W1234-460	505/500	2.67-26.70ppm / 0,15-1,5°dH / 0,27-2,68°f
W1234-461	510/500	5.34-53.40ppm / 0,3-3,0°dH / 0,54-5,36°f
W1234-462	520/500	10.68-106.8ppm / 0,6-6,0°dH / 1,07-10,71 °f
W1234-463	530/500	16.02-160.2ppm / 0,9 - 9,0°dH / 1,61-16,07°f
W1234-464	550/500	26.70-267.0ppm / 1,5-15°dH / 2,68-26,79°f
W1234-465	600/500	53.40-534.0ppm / 3,0-30°dH / 5,36-53,57°f
<b>Carbonate Hardness (Alkalinity)</b>		
W6050-710	C-710/500	5.34-53.4ppm / 0,3-3,0°dH / 0,54-5,36°f
W6050-715	C-715/500	8.01-80.10ppm / 0,45-4,5°dH / 0,80-8,04°f
W6050-720	C-720/500	10.68-106.8ppm / 0,6-6,0°dH / 1,07-10,71°f
W6050-730	C-730/500	16.02-160.2ppm / 0,9-9,0°dH / 1,61-16,07°f

N.B. Indicators 530/500 and above are very temperature sensitive and it may be necessary to correct the test results with reference to the environmental temperature.



The reagents are available in 500ml bottles. This amount is sufficient for about 10,000 analyses at low hardness. The number of analyses is dependent upon the hardness level and the reagent used.

**Reagents that are not in use should be stored in a cool dark place. Avoid direct sunlight. The shelf life of the reagents is at least 24 months if stored below 25°C and in a dark place. High temperature and direct sunlight can significantly reduce the shelf life!**

## 2.7 Maintenance sets

The analysis unit needs very little maintenance. There is a **maintenance set** available for the analysis unit. It is recommended to change the dosing-pump cassette, the reagent pipes and the 'o'-rings after 50,000 analyses or every 6 months.

It is also recommended that the measuring chamber is regularly cleaned – at least every 6 months. The cleaning set is offered for this purpose. This set contains everything necessary in the way of equipment including the cleaning fluid.

Article		Order number
Maintenance set for the 6051		W6050-906
Cleaning set for the 6051  Cleaning set for the chamber		Road transport: W6050-213  Air transport: W6050-213S

### 3 General Safety

Please observe the following safety instructions before operating the unit.

We wish to inform you of the appropriate use, installation and maintenance of the **analyzer** in order to ensure a safe, problem free operation. Please take careful note of the possible dangers that may result from incorrect use. The safety symbols are explained and fundamental instructions given. The reading of this chapter does not replace technical training. **The installation and the commissioning of this unit should only be carried out by an authorized and qualified person.**

This handbook describes the installation and the operation of the on-line **analyzer** for the automatic ascertainment of water hardness.

This unit may only be used in accordance with the conditions described in this handbook. In particular, the unit must be protected from wet and damp. The protection class of the unit on an open mounting plate is IP43. When mounted in a protective case, the protection class is IP54. Splashing or condensation should be avoided. The unit may only be used for the specified purpose. During installation and operation of the analysis unit, the relevant regulations (e.g. EN, DIN, VDE, UVV) should be observed.

The analysis unit should only be used to ascertain the total water hardness or the carbonate hardness in the sample water. **Correct operation can only be warranted if the manufacturers recommended reagents and spare parts are used.**

Changes to the electrical wiring and the programmes should only be carried out by a designated and qualified person.

The connecting cables should be kept as short as possible and not laid next to, or in close proximity to, power cables. Analysis may be adversely affected by strong electromagnetic fields. In this case special protective measures should be applied. Correct earthing is essential.

It is recommended to have these operating instructions at hand during the initial operating of the equipment in order to get an immediate understanding of the functions. Since the various ideas build upon the previous information it makes sense to work through the chapters in their printed order.

If any problems occur or questions arise during the operation of the analysis unit, you can get assistance from your supplier. Try to locate the problem as accurately as possible or to record the action and conditions that lead to the problem. This makes speedy assistance possible.

## Safety Instructions and Symbols

In this handbook you will find various safety details that warn of possible dangers associated with the use of the analysis unit. This applies to specific dangers to:

- Persons
- This product or connected equipment and installations
- A working environment

Various symbols in this handbook point out special dangers for the purpose of protecting persons and equipment from injury or damage. Please read the whole text completely before you start working.



**Danger**

This symbol warns of possible danger of injury.



**Warning**

This symbol warns of a general risk to the unit, the installation, the materials, the working area and the persons therein.



**Pressure**

This symbol warns that the parts may be under pressure.



**Voltage**

This symbol warns of the danger of electrocution as well as damage to electrical parts.



This symbol warns of a general risk and the need to take note of certain conditions.



This symbol is to make the user aware of useful tips to improve the understanding of this unit.

### **Working with pipes that are under pressure**

Maintenance and repair work are only to be carried out by qualified persons.

- Before you begin, make sure there is no pressure in the pipes.
- Pipes, joints and seals are to be checked regularly and where necessary, or as a precautionary measure, replaced. Maintenance intervals should, in any case, be observed.
- Before operating after maintenance, ensure that all joints, fittings and seals are correctly fitted. Check that all casing parts are closed and filters or other parts connected to the unit are correctly fitted.
- Remove all maintenance tools, parts and other materials before operating the system.
- Clean the unit and wipe up any fluids that have run out thereby leaving the unit in a clean condition.
- Check that all safety systems are in position and working.

### **Transport**

Protect the analysis unit during transport. Remove any remaining fluids. Remove the reagent bottle and firmly close it to avoid any spillage.

Transport unit carefully and do not throw it.

Avoid direct sunlight, moisture and high temperatures.

Immediately on delivery, check that the unit is complete and has no damage. Even though the unit is well packed, damage can occur during transport. In the event of damage, inform the deliverer immediately.

### **Storage**

Do not store for more than a year on account of the guarantee. Only store the analysis unit in a cool, dry place with temperature between 5 and 45°C and avoid direct sunlight.



---

### Scope of Delivery

Check that all the ordered components are present.

Damage or missing parts are to be reported within 7 days of delivery. Later claims will not be accepted.

### Installation

The installation should be carried out in the following order to avoid errors:

- Install the analyzer in a dry and easily accessible place.
- Fix securely according to the mounting instructions.
- Power up the unit with the correct supply voltage as noted on the type label.
- Connect the inlet and outlet pipes according to the installation instructions.
- Insert the reagent bottle and connect to the dosing pump. Make sure the pipe is not twisted.
- Set the unit up according to the instructions in the following sections.
- Only switch on the unit when all preparation is done, the case is closed and the unit is set up.

## 4 Installation

### 4.1 Wall mounting without case

The analysis unit must be installed vertically. In the mounting plate there are 4 holes for fixing the unit as shown in the following drilling plan:

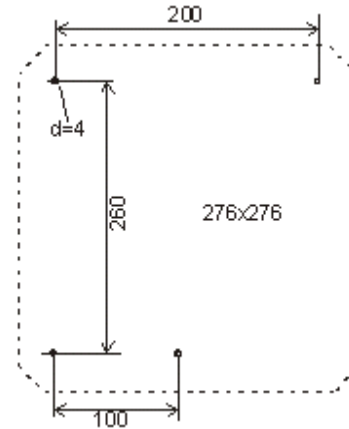

### 4.2 Wall mounting with case

The analyzer can be delivered with a compact protection case as an optional extra. The case is delivered with the unit already mounted inside and 4 mounting brackets for fixing the case as shown in the drilling plan below:

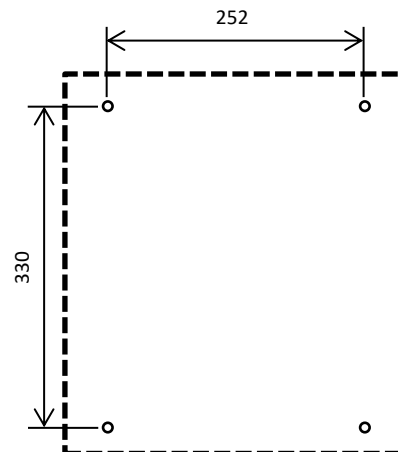

To allow for opening the case, the designated mounting space must be at least 450x350mm (D xH).

### 4.3 Water Connections

The ideal input pressure for the analysis unit is between 1 and 2 bar, and at least 0.2 bar. In the water inlet pipe is an input valve which, when closed, allows the measuring chamber to operate without push. The unit can also be operated with an input pressure of up to 5 bar, however when the push is released, gassing may occur.

It is recommended to reduce the push with a simple valve. A push reducer is not necessary.

**The sample water must be clear and free of solid particles or a filter installed. Solid particles in the water can damage the magnet valve or prevent it from closing. If the magnet valve is blocked or doesn't open and close properly, the measuring chamber will not be properly flushed and this could lead to erroneous measurements.**

The sample water temperature should not be less than 5 °C or greater than 40 °C.

If the sample water has a higher temperature, a pre-cooler should be installed. These coolers are available as accessories.

The analysis unit has 2 connections with fittings for plastic pipes with an external diameter of 6mm for the water inlet (left) and the water outlet (right). These only need to be pushed into the fittings.

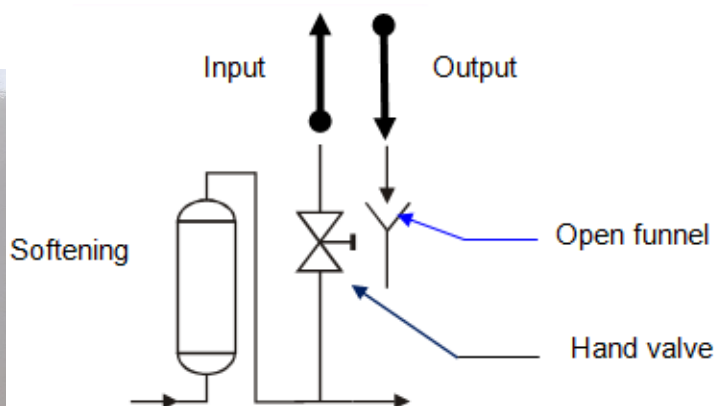

**The water outlet should be as short as possible and the water should be able to run away vertically and freely. The system output must be at atmospheric pressure. The output pressure must not exceed the input pressure. The pipes should not be laid horizontally. Pipes should not exceed 2m in length. The output water must run into an open funnel or waste water pipe/drain.**



#### **4.4 Operating with pressure-less sample water**

If the sample water is not under pressure, a simple membrane or immersion pump is necessary to deliver the sample to the analysis unit. Relay 4 can be used for this purpose.

## 5 Electrical Installation

Please note that all electrical installation work should only be carried out by authorized specialist personnel in compliance with the current regulations. Make sure that cables are not connected to power.

**The required supply voltage is 85-305 VAC (47-440 Hz)**

Open the lid of the controller by loosening the four screws in the corners of the lid.

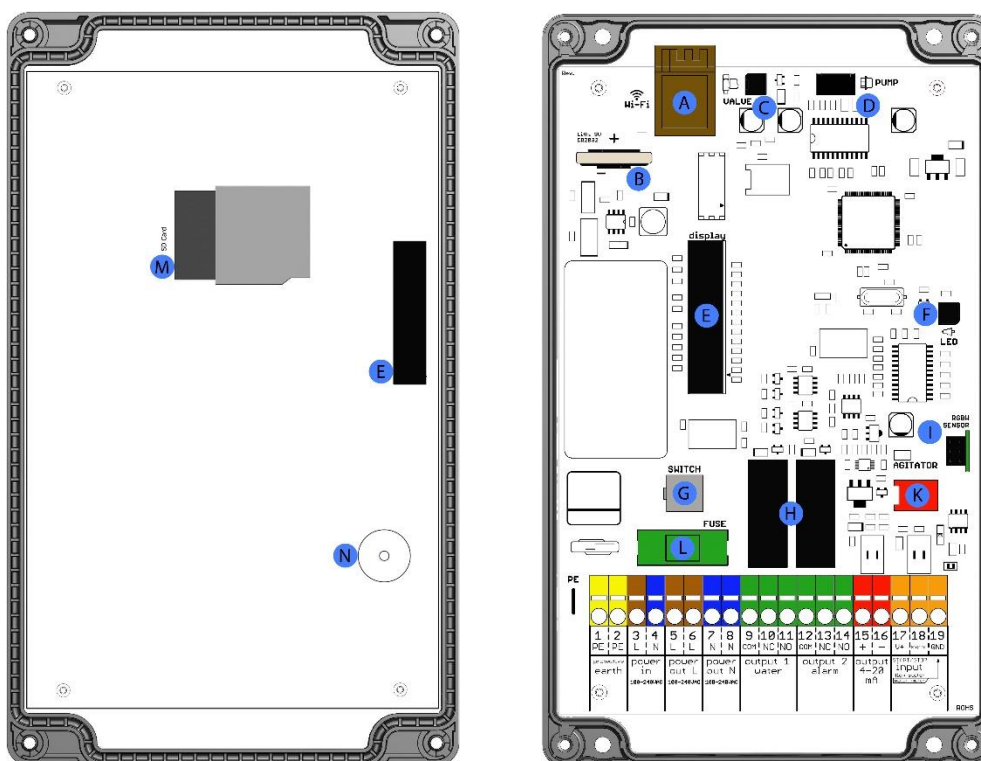

Figure: Back cover of the lid (left side), circuit board (right side)

Position	Description	Position	Description
A	Wi-Fi (optional)	H	2 x relay
B	Battery holder	I	RGB sensor
C	Solenoid valve port	K	Agitator port
D	Reagent pump port	L	Fuse (5 x 20 mm) 1 A time-lag
E	Display port	M	SD card base
F	Actuator plug LED port	N	Sound emitting device
G	Main switch port		

### 5.1 Connecting the supply voltage

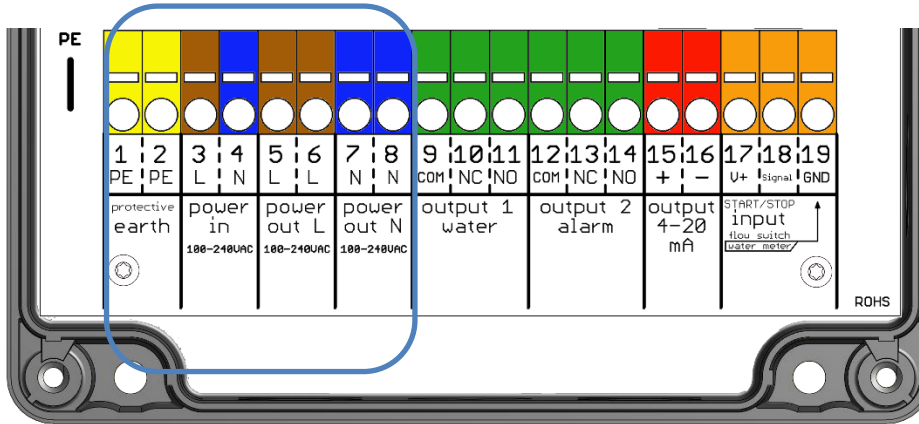

Figure: Terminals for the connection of the supply voltage (blue border)

Connection of supply voltage:

Terminal Designation	Description
1 PE	Earthing
2 PE	Earthing
3 L (power in)	Supply voltage between L and N 85-305 VAC (47-440 Hz).
4 N (power in)	

Output terminals which are connected via the device switch

Terminal Designation	Description
5 L (power out)	Switched supply voltage between L and N 85-305 VAC (47-440 Hz).
6 L (power out)	
7 N (power out)	
8 N (power out)	

Take care to make a good earth contact to avoid possible malfunctions of the unit.

The mains output appearing on the top row can be used via the output relays to drive pumps, valves or others. The total consumption of all the connected appliances must not exceed 500 VA.

## 5.2 Connection of the Relay Outputs

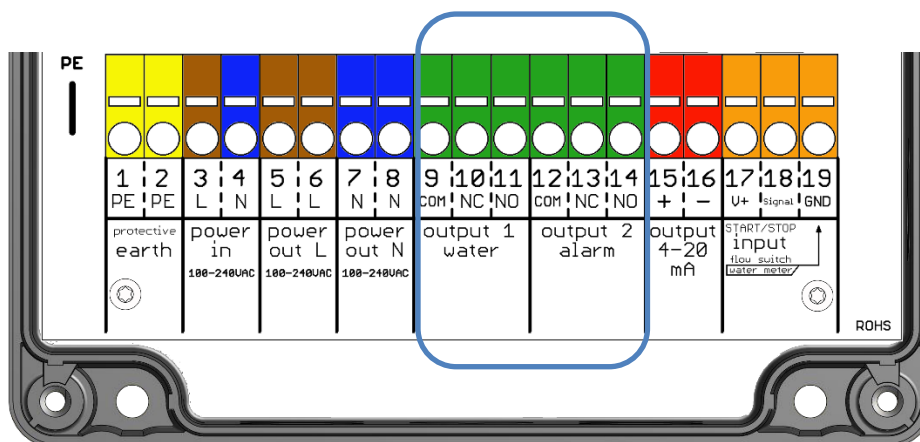

Figure: Terminals for connecting the relay outputs (blue border)

The relays are designed as change-over contacts, with a common connection and the switching outputs NC and NO.

*Output 1 water (relay 1): Water hardness notification*

Terminal Designation	Description
<b>9 COM</b>	Relay 1 COM common connection
<b>10 NC</b>	Relay 1 NC normally closed
<b>11 NO</b>	Relay 1 NO normally open

*Output 1 / relay 1 function (notification of water hardness):*

If the measured value of the sample falls below the limit set in the analyzer, relay 1 is de-energized and a connection from COM to NC is established. In addition, the symbol R1 is not marked in the display.

If the measured value of the sample exceeds the limit set in the analyzer, relay 1 is energised and a connection from COM to NO is established. In addition, the symbol R1 is highlighted in black on the display.

Output 2 alarm (relay 2): Device error notification

Terminal Designation	Description
12 COM	Relay 2 COM common connection
13 NC	Relay 2 NC normally closed
14 NO	Relay 2 NO normally open

Output 2 / relay 2 function (device error notification):

If a device error occurs or the device is switched off, the relay 2 is de-energized (connection from COM to NC). In addition, the symbol R2 is not marked in the display.

The relay 2 is energised in the error-free state of the device (connection from COM to NO); this serves the wire break safety. In addition, the symbol R2 is highlighted in black on the display.

### 5.3 Connecting the analog outputs

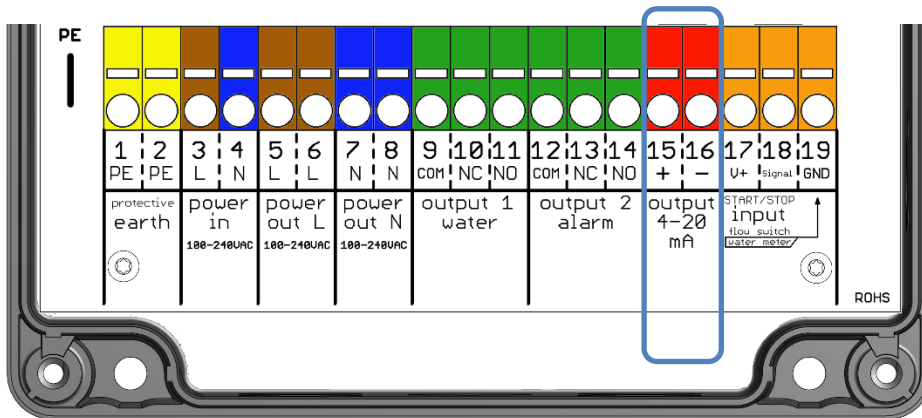

Figure: Terminals for connecting the current interface contact (blue border)

Output 0/4 – 20 mA: Current interface

Terminal Designation	Description
15 +	+ Output 0-20mA or 4-20mA
16 -	- Output 0-20mA or 4-20mA

*Current interface function:*

The current interface is used to provide the present water hardness or device status as current output. The current range can be selected between the settings 0 - 20 mA or 4 - 20 mA. The maximum load is 750 Ω.

*Selection options for current interface type:*

- From
- 0 – 20 mA value
- 4 – 20 mA value
- 0 – 20 mA status
- 4 – 20 mA status

### 5.4 Connecting the digital inputs

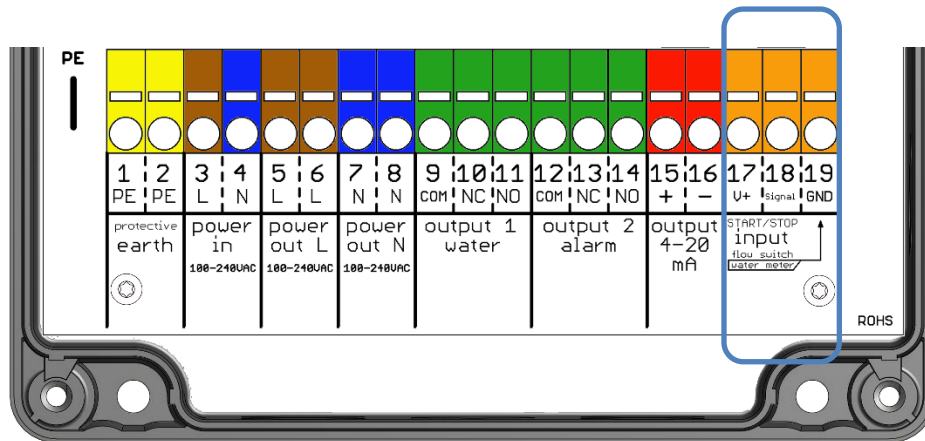

Figure: Terminals for connecting the input contact (blue border)

Terminal Designation	Description
17 V+	+ 24 V auxiliary voltage to connect potential-free outputs
18 Signal	Signal Input
19 GND	Ground connection for the +24 V connection

*Input contact function:*

A flow switch or other potential-free switches can be connected to the input contact. If the input contact is closed, the symbol IN is highlighted in black on the display.

## 6 Connecting the External Components

### 6.1 Connecting the External Components

To connect additional components, the device is equipped with an input, 2 relays and an analogue output (current interface 4 - 20 mA). A flow switch, a potential-free switch or an electronic switch (open collector) can be connected to the input. An auxiliary voltage of 24 VDC is connected at terminal 17, and GND, at terminal 19. For signal detection, 24 VDC must be bridged to terminal 18. No external voltage sources may be connected to the input. If necessary, a potential separation must be made with a relay or optocoupler.

The connections of the relays are all brought out potential-free. For switching external devices, the internal network voltage or alternatively an external supply voltage can be used. The connection to external controllers is usually established via the potential-free contacts of the relays.

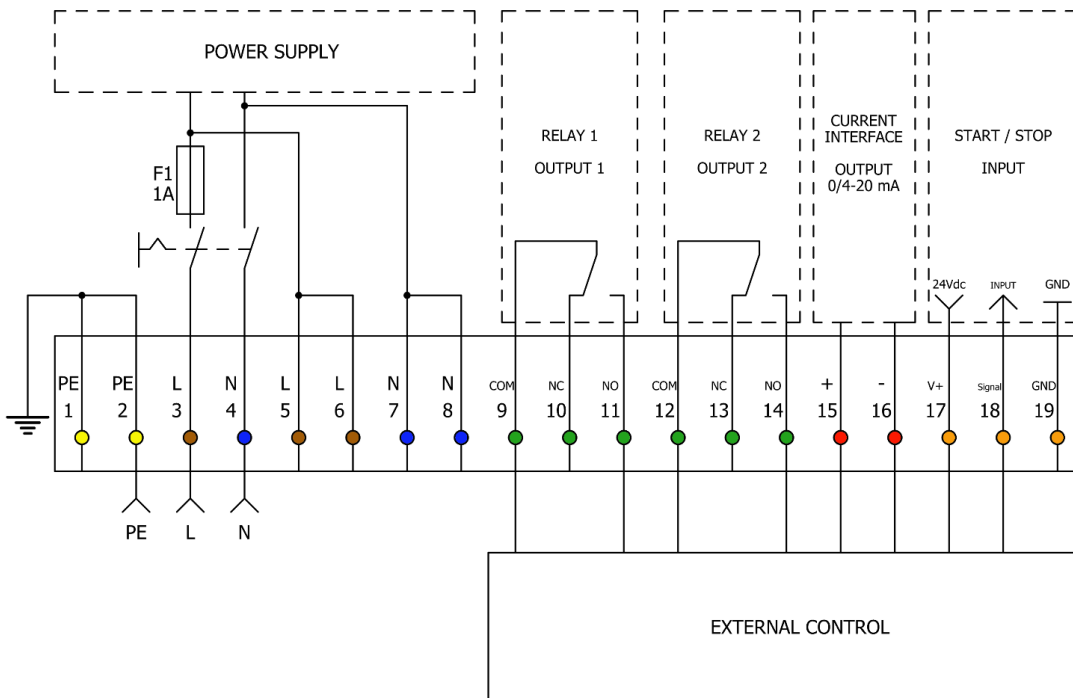

Figure: Schematic plan view of connection terminals

## 6.2 Switch for Starting the Analysis Externally

In addition to the option of running an analysis on a time-dependent basis, there is also an option to trigger additional analyses using an external button. This can be a potential-free push-button or the relay output of a PLC controller or water softening controller.

The use of a switch at the input is intended as an addition to the normal time interval. The analyzer operates at a set time interval. A signal can be delivered to the input via the switch and thus an additional analysis can be started.

(When using this function, the analyzer must be in automatic mode.)

Programming: Menu > Settings > Input > Start analysis

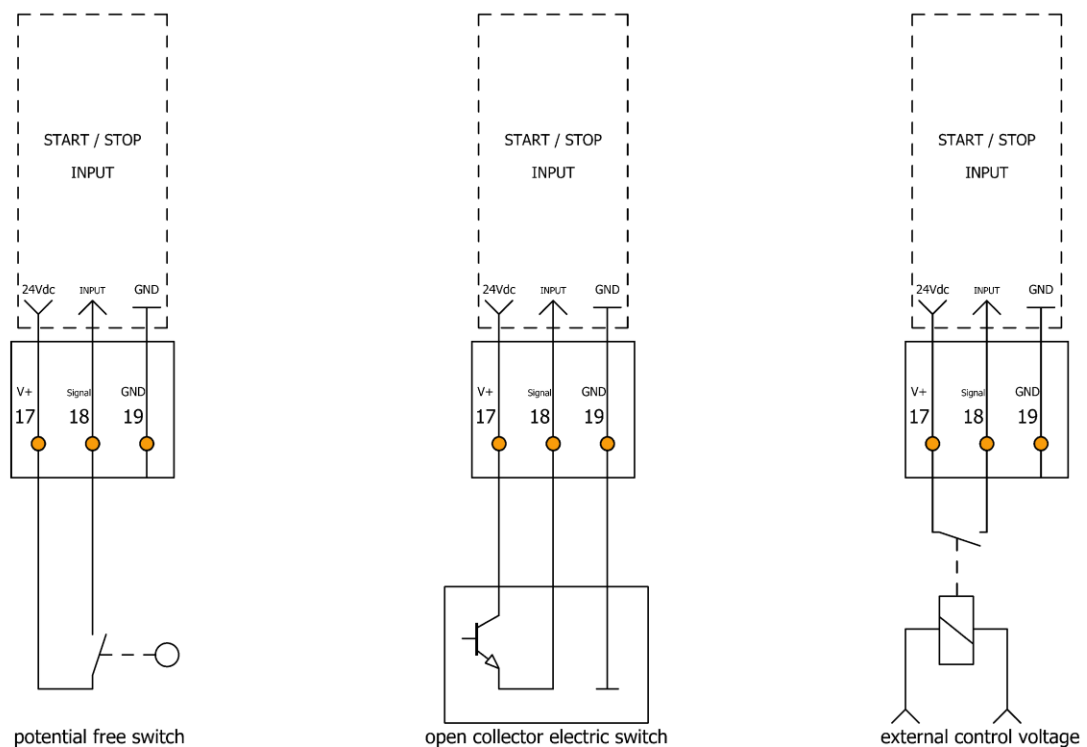

Figure: Three possible connection variants to start the analyzer with an external controller

### 6.3 Flow Switch

Typically, an ion exchanger is monitored every 10 minutes to ensure that hard water does not reach the load in the event of a sudden hardness irruption. When installed on a system where monitoring is required only during operating hours, the input contact can be used in combination with a flow switch or a timer. Thus, the time interval can be paused during a system downtime, which can reduce reagent and power consumption.

As a flow switch, a paddle can be used. Potential-free contact of a timer is also possible. The examples below show various connection options at the input contact.

When using a flow switch, the analyses are only carried out if a defined signal is present at the input (input) (flow switch reports flowing water).

Depending on the installed contact, the input can be configured as NC or NO type.

(When using this function, the analyzer must be in automatic mode.)

Programming: Menu > Settings > Input > Flow switch

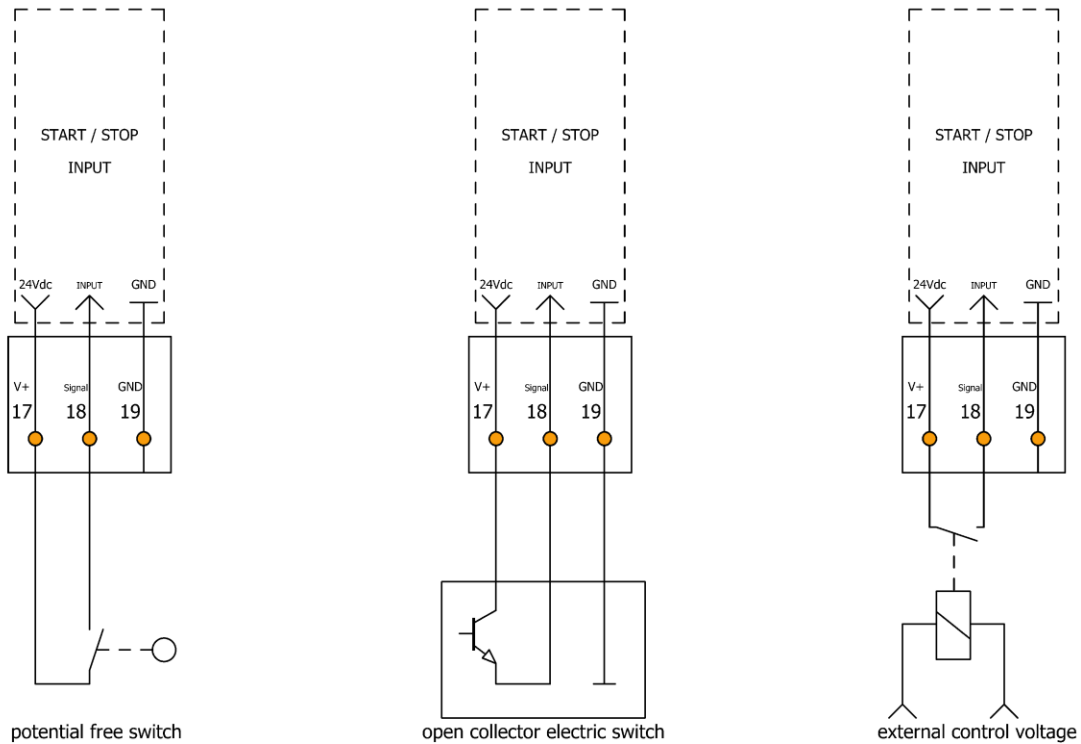

Figure: Three possible variants for connecting a flow switch

## 6.4 Interval Reset

Input IN as reset of interval during automatic mode.

The mode interval reset is used during monitoring single or pendulum softening systems.

During operation of the water softening system, the analyses are running in the programmed analysis interval. When regeneration starts, the input contact closes to stop the analysis interval. The last display value is deleted from the display and the analysis interval pauses if the input contact is closed. After completion of the regeneration or after switching to the second water softening system, the input contact is opened again. The first analysis starts after one minute. The following analyses are performed again in the programmed analysis interval.

Input contact is closed: Analyses are stopped immediately and paused as long as the input contact remains closed.

As soon as the input contact is opened, the analysis interval begins, but since no display value is yet in the display, the first analysis is carried out after 1 minute before the set analysis interval begins (e.g. 5 min).

(When using this function, the analyzer must be in automatic mode.)

Programming: Menu > Settings > Input > Interval reset

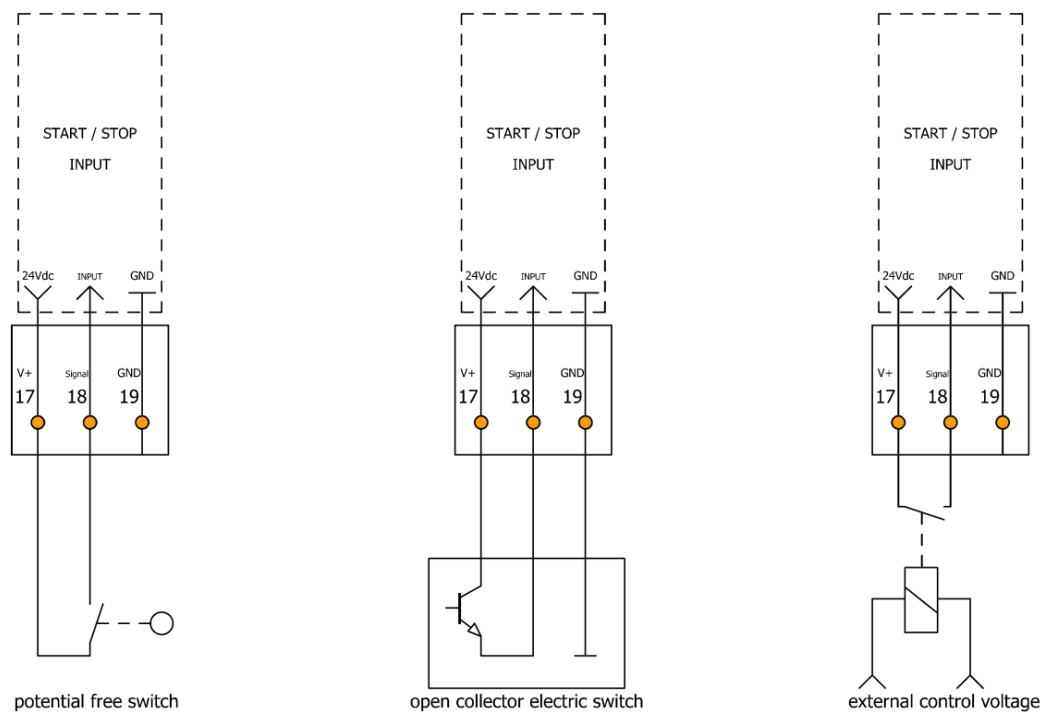

Figure: Three possible variants for connecting a reset switch

## 6.5 Reagent Light/Horn

A reagent light or horn to signalise a limit violation can be connected to relay 1 / output 1.

Relay 1 / output 1 is energised when the limit value is exceeded and the connection from COM to NO is made. This position can be programmed in the program as a permanent contact or as a pulse contact.

### *Continuous contact on relay 1 / output 1:*

Relay 1 / output 1 remains switched in the position (connection from COM to NO) when the limit value is exceeded until the measured water hardness is below the limit again. Next, the limit value excess is lifted and relay 1 / output 1 is switched back (connection from COM to NC).

### *Pulse contact on relay 1 / output 1:*

Relay 1 / output 1 remains switched in the position (connection from COM to NO) only for a programmed pulse duration when the limit value is exceeded. Once the programmed pulse duration expires, relay 1 / output 1 switches back (connection from COM to NC). The next time the limit is exceeded, relay 1 / output 1 is switched again as a pulse.

Programming: Menu > Settings > Outputs > Relay 1

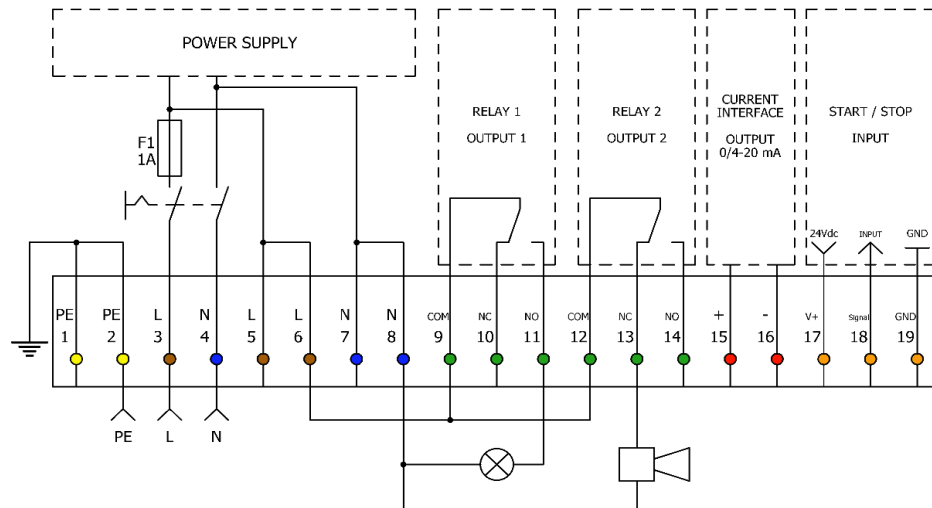

Figure: Terminal assignment when connecting reagent light / horn

The relay 2 / output 2 is used to report detected errors (e.g. optical error, faulty zero sample, missing supply voltage at the analyzer). If the analyzer is in normal operation and there is no fault, relay 2 / output 2 is energised and the connection from COM to NO is made. If an error is detected, the relay 2 / output 2 is de-energized and the connection from COM to NC is established.



## 6.6 Regeneration System for Demand-Controlled Regeneration Triggering

Preparation plants are usually regenerated according to their capacity according to a constant flow rate. To ensure that no hard water reaches the load, the regeneration takes place before the actual exhaustion of the plant. If regeneration is triggered by an analyzer, regenerants and water are saved. In the case of strongly fluctuating raw water hardness, a qualitative regeneration triggering via an analyzer is unavoidable.

The pulse output for the regeneration triggering takes place via relay 1 / output 1. Due to longer service life or due to excessive load, premature regeneration can be triggered by the counter ion effect. It is therefore recommended to repeat the measurement if the limit value is exceeded with a control measurement.

Programming: Menu > Settings> Analysis> Control measurement

## 6.7 Analogue Measuring Device

The present measured value is available as an analogue value at terminals 15 and 16. Recorders or external devices can be connected to process the measured value. You can choose between a current output 0 - 20 mA value or a 4 - 20 mA value. In addition, you must specify which current value of 20 mA corresponds to which total hardness / carbonate hardness.

Programming: Menu> Settings > Outputs> Current loop type

Programming: Menu > Settings > Outputs > Current loop calibration

(Enter the total hardness / carbonate hardness value that should correspond with 20 mA.)

The supplied current of the current loop for the displayed measured value is calculated as:

$$I = I_0 + \frac{(20 \text{ mA} - I_0) \cdot \text{MeasuredHardness}}{\text{Max\_Hardnessvalue}} [\text{mA}]$$

Here,  $I_0$  is to be set to 0 or 4 mA depending on the operating mode.

The number "Max Hardness value" corresponds to the entered water hardness value for 20 mA.

Usually, the end of the measuring range of the reagent deployed is used.

*Example of calculation:*

For the analysis, a reagent 503/500 is used. Measuring range 0.09° dH to 0.9° dH.

Upper hardness is set to 0.9° dH, which corresponds to 20 mA.

*Calculation for current interface type "0 - 20 mA"*

$$I = 0 \text{ mA} + \frac{(20 \text{ mA} - 0 \text{ mA}) \cdot 0,42 \text{ }^\circ\text{dH}}{0,9 \text{ }^\circ\text{dH}} [\text{mA}]$$
$$I = 9,3 \text{ mA}$$

9.3 mA corresponds to 0.42° dH.

*Calculation for current interface type "4 - 20 mA"*

$$I = 4 \text{ mA} + \frac{(20 \text{ mA} - 4 \text{ mA}) \cdot 0,42 \text{ }^\circ\text{dH}}{0,9 \text{ }^\circ\text{dH}} [\text{mA}]$$
$$I = 11,46 \text{ mA}$$

11.46 mA corresponds to 0.42° dH.



## 6.8 Operating Status via Analogue Current Interface

The operating status of the device can be transmitted via the current interface terminals 15 and 16.

Programming: Menu> Parameters> Outputs> Current interface type

Selection options:

- 0 – 20 mA status
- 4 – 20 mA status

Operating status	Current interface	
	0 – 20 mA status	4 – 20 mA status
Standby (until first analysis is complete)	3.5 mA	6.8 mA
Fallen short of limit	7.5 mA	10.0 mA
Limit exceeded	12.5 mA	13.6 mA
Reagent fill level < 10%	16.5 mA	16.8 mA
Fault	0 mA	4 mA

## 7 Components and Operation

### 7.1 Location of Components

The analysis unit consists of the following components: On the left hand side is the control box with a graphic display and operating field. On the underside of the control box there are 4 cable entry fittings, to the right, the dosing-pump and under that, the measuring chamber.

The dosing-pump is simply clipped on and can easily be removed without tools. The measuring chamber hangs on 2 studs on the control box and can also be removed without tools simply by pulling the 2 securing pins. Similarly, the reagent dosing plug, the input and output plugs are mounted on the measuring chamber and can easily be removed.

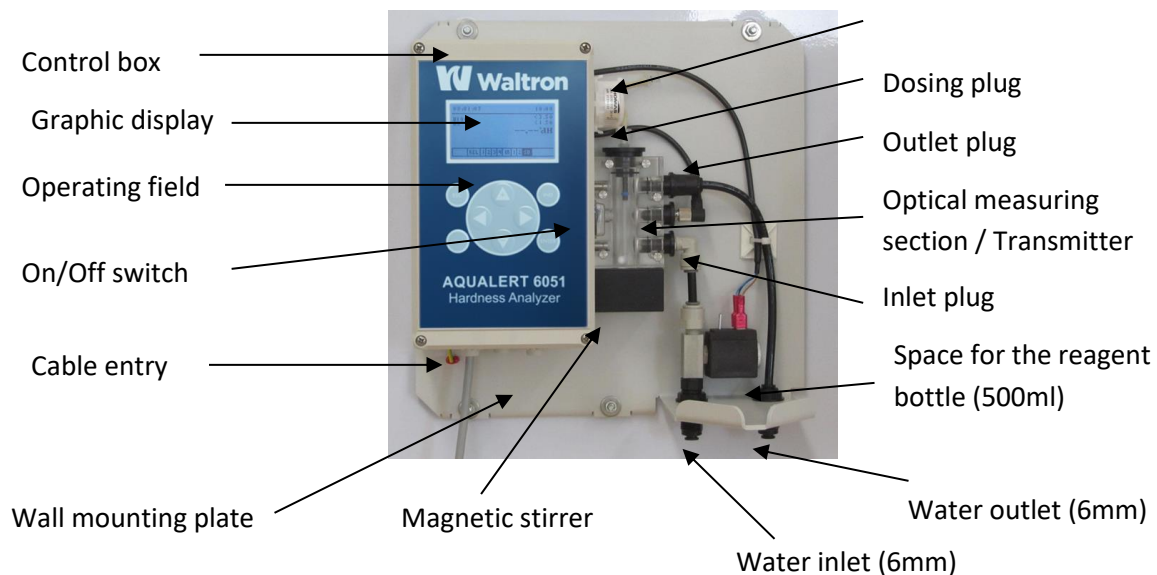

**The securing pins can only be pulled and not removed.**

The measuring chamber is always at atmospheric pressure and full of water in order to avoid the development of algae. In the middle of the chamber is the white high powered LED transmitter. The sensor is located inside the control box. A magnetic stirrer is located underneath the measuring chamber. The magnetic stirring unit is securely fixed to the chamber.

At the bottom right of the mounting plate you will find the water inlet (left) and outlet (right) connectors both of which are secured to the mounting plate. The solenoid input valve is located behind the reagent bottle.

Solenoid valve in  
the inlet line



## 7.2 Display and keyboard

The analysis unit has a graphic display that displays both the test results and the operating menu. The unit is set up by means the 8 keys in the operating field. The background colour of the display changes according to the current function of the display:

Back-ground colour	Function
White	Unit is working normally
Red	Limit exceeded or unit fault

Located centrally in the middle are 4 keys for navigation and entry of values (<> + -):

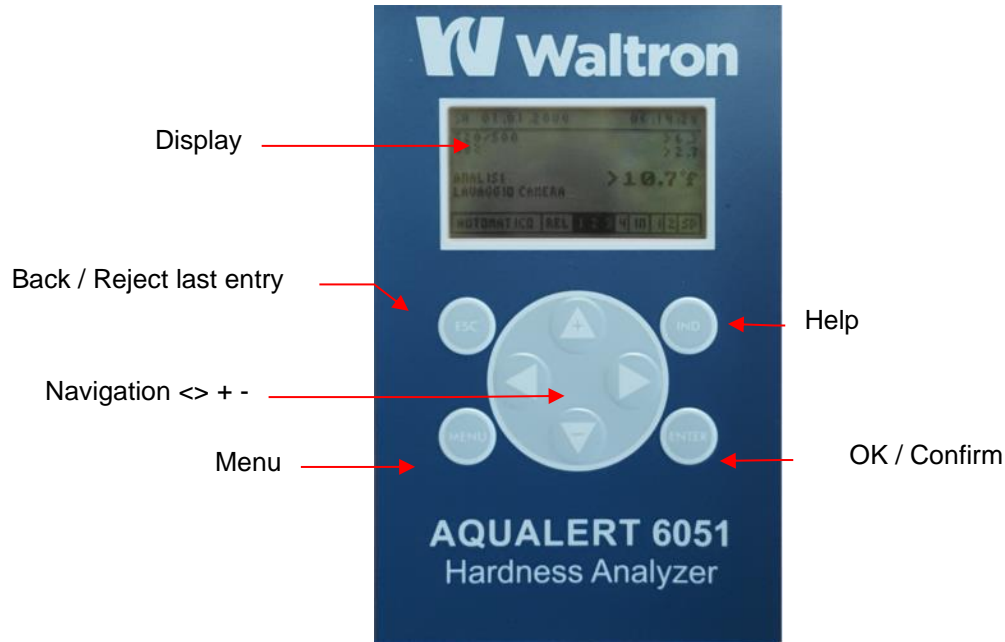

Additionally there are 4 function keys:

Key	Function
	Back / Reject last entry Cancel current analysis
	Enter menu Switch between menu and display of test results
	Reserved for Help function
	OK Confirm

The display can be switched between “menu” and “measurement” by means of the menu key.

**Display (Menu)**

The menu window offers the following choices:



<b>Automatic</b>	Starts the automatic analysis operation
<b>Manual (Service)</b>	In this mode the analysis unit can be operated by hand
<b>Parameter (Settings)</b>	Under this menu point various unit settings can be undertaken
<b>Assistant (Wizard)</b>	Starts the configuration assistants
<b>Info</b>	Informs about status of the software, date of manufacture and serial number of the unit
<b>History</b>	Shows the last 100 measurements as a graph

**Display (measurement)**

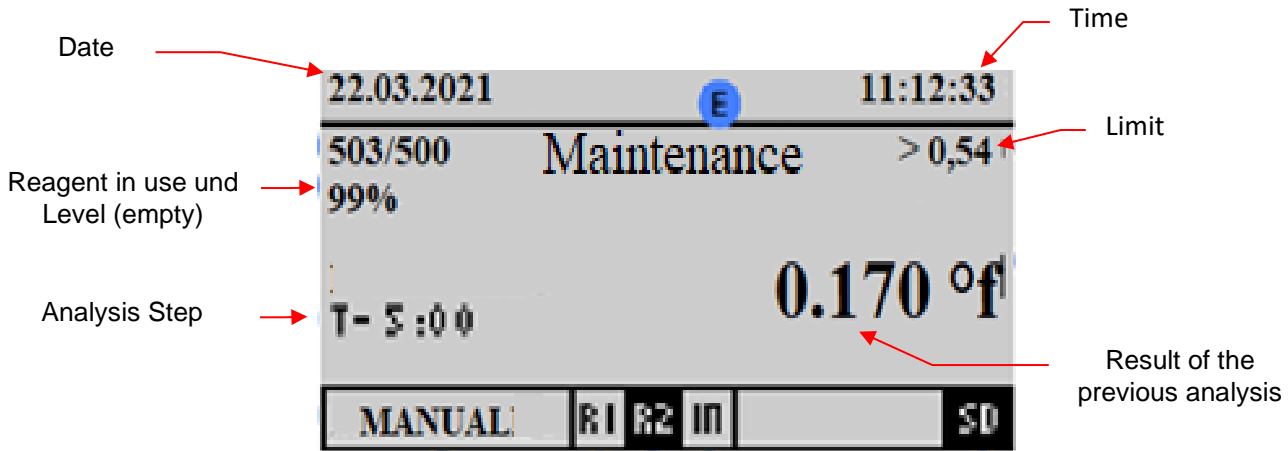

**Display (Reading progress)**

Status bar:

Automatic active

Relays 1-4 (1 de-energized, 2 energized)

Digital input 1

SD card present

With the help of the 'left' < and 'right' > keys you can call up the results history with date and time (max. 100 analyses). All results are stored on the SD-card and can be called up and read. The limit settings are shown as points on the graph.

You can call up the record by selecting Menu>History. By pressing the key [OK] or [Back] you can return to the measurement value.

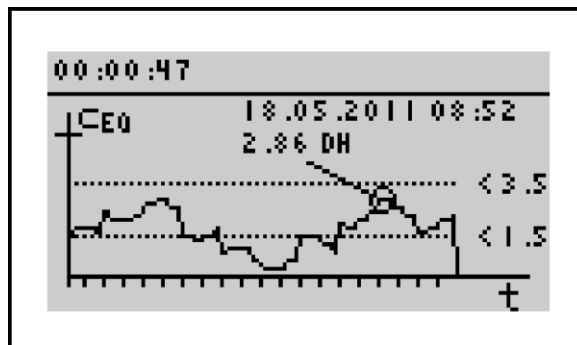

### Display (Select)

You can use the <> keys to change your choice. Confirm it with [OK]. If you do not wish to make a change, leave by pressing the [back] key.

In the figure below, the active choice is YES.

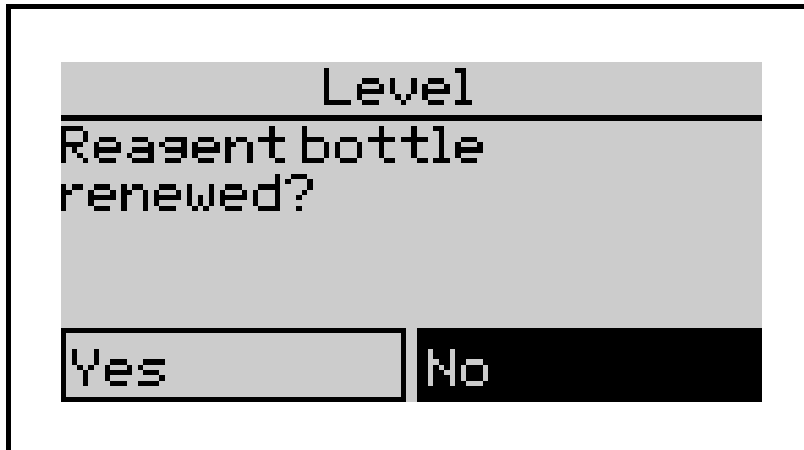

### Display (Selection lists)

You can navigate the selection list by the [▲] and [▼] keys. Confirm with the [OK] key. Leave the list with the [back] key. If there are more than 3 choices in the list, you can use the scroll facility on the right of the display.

In the figure below, the active choice is indicator 503/500.

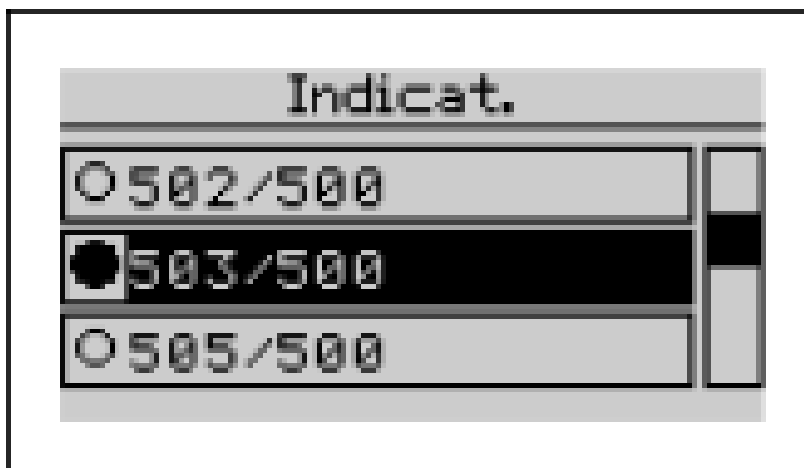

### Display (Entering a value)

Numbers can be given in via the virtual keyboard on the display. The cursor is moved by the < > ▲ ▼ keys. The entry mask shows the numbers given in.

When the cursor is not moved and the [OK] key pressed the highlighted number will be entered.

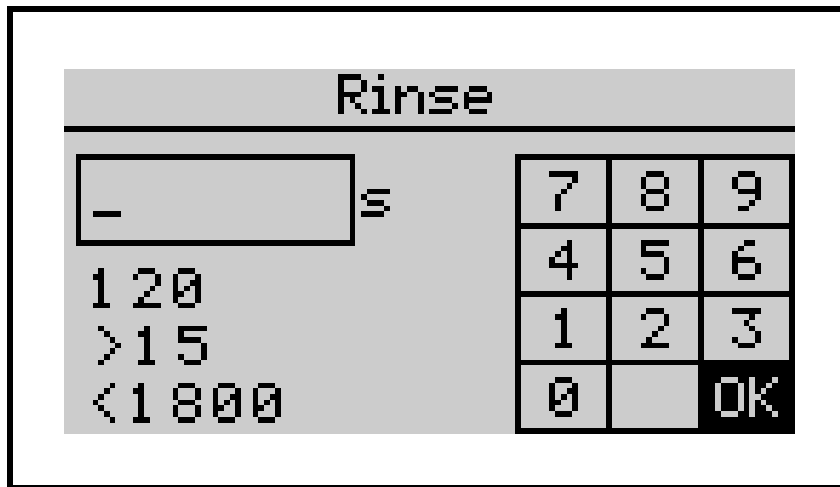

As an example: the flush time = 30 seconds.

The possible times are from 15 to 1800 seconds.

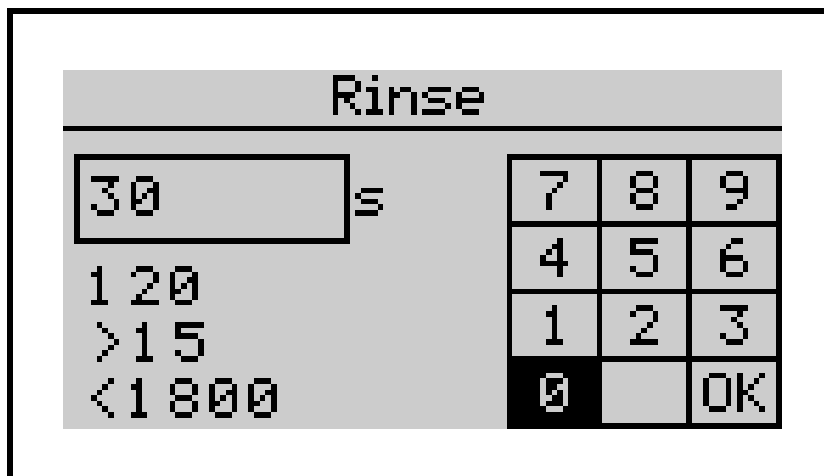

## 8 Configuration

### 8.1 Factory Settings

The following factory settings are stored in the device:

Menu items		Factory settings
General	Language	Italian or German
Analysis	Unit	°dH
	Reagent	503/500
	Limit value	0.5 °dH
	Flushing time	120 seconds
	Auto. Time interval	5 minutes
	Stop analysis	No
	Control measurement	No repetition
	Calibration factor	100 %
Input	Input	Start analysis
	Flow switch	From
Outputs	Current interface type	4 ... 20 mA values
	Calibrate current interface	0.9 °dH
	Relay 1	Limit as permanent contact
	Relay 2	Reporting of errors

### 8.2 Configuration Assistant

The configuration assistant serves to simplify the initial commissioning. Via the menu, the unit guides you step by step through all necessary settings. At the same time the full functionality of the unit is checked.

All settings of the menu parameters can later be changed again.

To start the assistant, select the selection assistant in the menu and confirm with [OK].

The following steps will be carried out:

Language Selection	Please choose your language. / Bitte wählen Sie Ihre Sprache. [OK]  Choice of language:
Your setting:	German, English, French, Italian, Polish, Spanish, Russian  Select and confirm with [OK]

Start  Configuration assistant	Do you want to start the configuration assistant?  [YES / NO] [OK]  YES: Starts the Configuration assistant  NO: Return to main menu
--------------------------------------	--

Works setting	Do you wish to reset the unit to the works settings?  [YES / NO] [OK]  YES: Resets the unit to recommended settings.  NO: The unit keeps your settings.
---------------	---

Select test parameters	Please select the test parameters  [OK]  You have the choice* between:  Total hardness or carbonate hardness
Your setting:	Select and confirm with [OK]  <i>* Further parameter are being prepared</i>



Select reagent	<p>Please select your reagent [OK]</p> <p>According to test parameters, a choice of possible reagents is now shown:</p> <p>Total hardness: 500S/500 to 600/500</p>
Your setting:	<p>Carbonate hardness: C710/500 to C730/500</p> <p>Select and confirm with[OK]</p>

Deliver reagent	<p>Place a new bottle of reagent in position [OK]</p> <p>The reagent pump starts the delivery of reagent. The delivery can be stopped with [OK]. After ca. 30seconds reagent will have reached the measuring chamber.</p>
-----------------	---

Select unit of measurement	<p>Select the unit in which the test results should be displayed. [OK] You will get a choice of possible measurement units according to the measurement parameters:</p>
Your setting:	<p>°dH, °f, ppm(CACO3), mmol/l, mg/l, mval/l, e</p> <p>Select and confirm with[OK]</p>

Set flushing time	<p>Give in the required flushing time.[OK]</p> <p>Flushing time: 0001 – 9999seconds</p> <p>The flushing time must be set according to the length of the inlet pipe and the water pressure. It must be sufficiently long to allow a complete change of sample water in the chamber.</p>
Your setting:	<p>Select with navigation keys and confirm. [OK]</p>

Flushing	You will now be invited to flush the system [OK]. Flush as long as necessary to rid (as far as possible) the chamber of bubbles. You can end the flush with [OK].
----------	---

Set limit mode	<p>Choose the mode of limit 1 and limit 2.</p> <p>Select with navigation keys and confirm.[OK]</p> <p>With this choice, you set the unit's logic to limit monitoring.</p> <p>In a softening system, the test result should lie below limit 1 (warning) and below limit 2 (error).</p>
Your setting:	<p>In a blending system, on the other hand, the test result should lie <i>between</i> limit 1 (lower limit) and limit 2.(upper limit)</p>

Set limit 1	<p>At what value should the monitoring of limit 1 take place?[OK]</p> <p>You can see this mask:</p>
Your setting:	<div data-bbox="716 1098 1040 1278" data-label="Image"> </div> <p>Via the navigations-keys, you can select the value and confirm [OK].</p> <p>The recommended value is displayed under the entry box pressing [OK] accepts this suggestion. The minimum and maximum values for the selected indicator are shown behind the &lt; and &gt; symbols.</p>

Set limit 2	<p>At what value should the monitoring of limit 2 take place?[OK]</p> <p><b><i>The limit must be greater than limit 1.</i></b></p>
Your setting:	<p>Via the navigations-keys, you can select the value and confirm [OK].</p>



Set analysis start	Select whether the analysis should be started after a time interval, after a discharge or both.[OK]
Your setting:	You have the possibility to start an analysis via one of the following: External contact, time, amount, time and amount
Your setting:	Select and confirm [OK]. <b>Select [external contact]</b> After selecting external contact, no further settings are necessary.  <b>Selection [time]</b>
Your setting:	After selecting time, you will be invited to select a time interval between measurements: Select the required time interval [OK]. 001 – 999 min Via the navigations-keys, select the value and confirm [OK] <b>Selection [amount]</b>
Your setting:	Select the unit of measurement for the amount of water discharged [OK] You are given the following choices: l, hl, m3, gallons(US), gallons(Imp) Select the value using the navigations-keys and confirm[OK] Select the amount after which the analysis should start [OK]
Your setting:	e.g. 1000 l Select the value using the navigations-keys and confirm[OK] <b>Selection[time and amount]</b> As above.

<p>Test repetition, First result suppression</p>	<p>Set the number of tests that you require to be made following a failed test. [OK]</p> <p>You have the following possibilities:</p> <p>No repeat</p> <p>Repeat once</p> <p>Repeat twice</p> <p>Repeat 3 times</p> <p>Via the navigations-keys, you can select the value and confirm [OK].</p> <p>An analysis can produce a bad result after the system has stood a while. It is, therefore advisable to carry out a control test to confirm a result before an alarm is set off.</p>
<p>Your setting:</p>	

<p>Define input2</p>	<p>Choose the function of input2 [OK]</p> <p>You have the following possibilities:</p> <p>Deactivated, analyse start, Water-meter, Flow-monitor</p>
<p>Your setting:</p>	<p>Via the navigations-keys, make a selection and confirm [OK]. Different functions can be assigned to input2.</p> <p><b>Deactivated</b></p> <p>If the input is not used</p>
	<p><b>Analysis start</b></p> <p>The analysis can be started by a controller. This is only possible if the unit is ready and not already in the process of an analysis.</p> <p><b>Water meter</b></p> <p>This setting should be selected if the unit is to be controlled by an external water-meter.</p> <p><b>Flow-monitor</b></p> <p>This setting should be selected if an external flow-monitor is connected to the input and the analysis unit should only carry out tests at pre-set time intervals if water is removed from the system.</p>



Relay1 (Limit 1) Period or impulse contact	Do you need a period or impulse contact on relay 1?[OK] You have the following possibilities: Period / Impulse [OK]
Your setting:	By selecting impulse, you can set the impulse length to control a switch room:  001 to 999 seconds.
Define Relay 2	Choose the function of input 2 [OK] You have the following possibilities:
Your setting:	Limit 2 or reagent level <10%  Via the navigations-keys, make a selection and confirm [OK].  Alternatively, the reagent level can be configured to relay 4.
Relay2 (Limit 2) Period or impulse contact	Do you need a period or impulse contact on relay 2?[OK] You have the following possibilities: Period / Impulse [OK]  By selecting impulse, you can set the impulse length to control a switch room:
Your setting:	001 to 999 seconds.  Choose the function of input 4. [OK]
Define Relay 4	You have the following possibilities:  Analysis or reagent level <10%
Your setting:	Via the navigations-keys, make a selection and confirm [OK].  With analysis, you can control an external pump, the cool water valve of a sample cooler or an external controller.  Alternatively, the reagent level can be configured to relay 2.

Interface configuration	Select the operating mode for the current interface[OK]
Your setting:	<p>You have the following choices:</p> <p>Off, 0 to 20mA, 4 to 20mA</p> <p>Select the value via the navigation keys and confirm [OK].</p> <p>Current loop</p>
Your setting:	<p>Assigning a hardness-grade limit to the maximum output current (20mA)</p> <p>Formula for calculating the current:</p> $I = I_0 + \frac{(20mA - I_0) \cdot \text{result}}{\text{hardnessgrade limit}} [mA]$ <p>For <math>I_0</math>, 0 or 4 mA should be inserted according to operating mode</p>

CAN-interface configuration	<p>Do you wish to use the CAN interface? [OK]</p> <p>You have the following choices:</p> <p>YES / NO [OK]</p> <p>If you have selected YES, you will be invited to make the following choice:</p> <p>Choose the baud rate of your CAN net [OK]</p>
Your setting:	<p>10 kbits/s, 20 kbits/s</p> <p>Select the value via the navigation keys and confirm [OK].</p> <p>Choose the channel-ID, on which the unit is to be controlled [OK].</p> <p>Test result channel</p> <p>0000-CFFF</p> <p>Choose the channel-ID, on which the unit is to transmit</p>



Your setting:	the test results [OK].  0000- CFFF  Choose the channel-ID, on which the unit is to transmit the status message [OK].  0000- CFFF  Select the value via the navigation keys and confirm [OK].
---------------	--

**The unit is now completely configured.**

## 9 Operation

### 9.1 Mode

#### Manual and Automatic mode

The analyzer can be started in automatic mode (Menu> Automatic), depending on the time or via an external button or flow switch. In manual mode (automatic off), functions such as starting analysis, conveying reagent or flushing can be manually controlled. In addition, a diagnostic function is included in manual mode to test individual device components.

In automatic mode, analyses are carried out at the programmed interval or by external starting. After switching on, the automatic mode is active. The first analysis is started after switching on at the programmed internal interval after 3 minutes. All subsequent analyses are performed in the programmed interval

### 9.2 Main Menu

The main menu can be opened by pressing the [Menu] key from the measured value view.



Menu item	Description
Automatic	Changing between automatic and manual mode
Parameter	Setting the device and analysis parameters
Info	Overview of hardware- and software version and display of counter readings
Service	Functions for maintenance, diagnostics, and changing reagent
Assistant	Setup wizard for a guided parameterisation of the device
History	Display of the last 100 measurement results with date and time

### 9.3 Maintenance functions

Various functions of the analysis unit can be checked and tested via the menu point Menu > Manual > Diagnosis.

### 9.4 Action in event of power loss

Various settings can be saved on to the SD-card or to the internal memory. In the event of a power loss, the settings will be available at the next power-up. If the unit had been running in automatic mode, it will automatically re-commence analyzing after a short interval. The previous settings of amount and time intervals will still apply.

If the analysis unit fails and has to be replaced, you only have to remove the SD-card from the old unit and install it in the new. Using menu function Parameter> General > Settings, import the unit settings and test result history.

### 9.5 SD-Card

The analysis unit contains an SD-card. The following information is stored on this card: Test results, error reports, unit firmware.

The information is stored as .csv files. These files can be opened and further processed on an editor or table calculation programme (e.g. MS Excel, OO Calc). The system data remains on the SD-card (.bin).

The analysis unit is also fully functional without an SD-card. However, it will only store the last 100 test results in the internal memory.

If you use an SD-card other than the one supplied, it must be formatted as follows:

Memory capacity:	max. 2.0 GB
Data system:	FAT16
Size of the allocation data:	32 k Byte

Bigger SD-cards can be formatted under e.g. Windows 7 > START > execute command und then by entry of format x: /FS:FAT /A32K. X stands for the letter of the disc-drive assigned to the SD-card.

The following files are stored on the card:

File name	Type	Content
trend.csv	Data	<p>Measured values in tabular form with date, time and measured value The data becomes filed in the following format: YYYY.MM.DD [Tab] hh.mm [Tab] x.xxx [Tab] Unit [LF]</p> <p>The measured values (x.xxx) are stored on the device in the unit displayed.</p>
error.csv	Data	<p>Error messages in tabular form with time, date, and error. The data becomes filed in the following format: YYYY.MM.DD [Tab] hh.mm [Tab] Error code [LF].</p>
history.dat	System	<p>Time-stamped analysis results The device loads these into the internal memory at start-up.</p>
setting.dat	System	<p>Complete device setting of the analyzer (optional file). Before replacing the analyzer, you can transfer the saved device configuration directly to the new device. The export is located in the menu under Parameters&gt; General&gt; Export settings. The device configuration can be imported in the menu under: Parameters&gt; General&gt; Import settings.</p>
logfile.dat	System	<p>Date, time stamp and device start This file is needed for internal purposes.</p>
TA27xxx.bin	Operating system	<p>This file is not on the SD card by default. If there are any software updates for your analytical instrument, they will be made available to you by our sales partners or can be downloaded from our homepage. You can copy this file to the SD card and perform a software update. More information about installing a software update can be found on page <b>Error! Bookmark not defined.</b></p> <p>We recommend that you delete the file from the SD card after installing an update.</p>

## 9.6 Menu structure

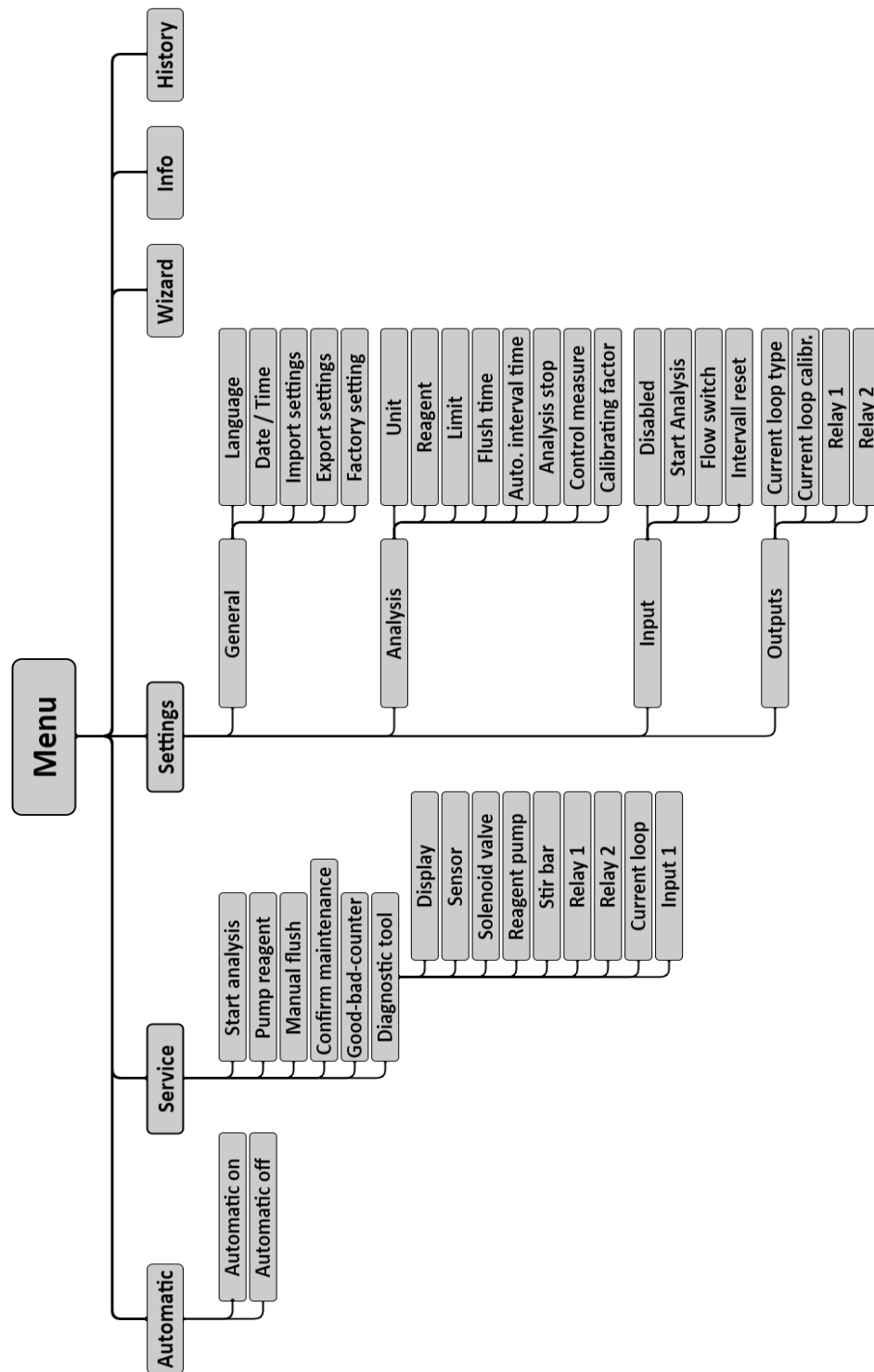

## 10 Maintenance and Service

In order to ensure a long and disturbance free functioning of the analysis unit, maintenance of the unit should be carried out at regular intervals. In most cases tools are not needed. Before commencing maintenance work, ensure that the unit is switched off. During this period, no analyses will be carried out. Always wear protective glasses and gloves while carrying out maintenance to avoid contact with reagent, cleaning fluid or water.

Please observe the following maintenance intervals

Every 6 months	Clean the measuring chamber (at higher environmental or water temperatures or high levels of biocides, it may be necessary to reduce the interval)
Every 12 months	Installation maintenance set

### 10.1 Cleaning the measuring chamber

The cleaning of the measuring chamber takes about 20 minutes. Proceed as follows to clean the measuring chamber:

- Switch off the device.
- Pull the hose pump cassette from the bracket by unlocking the clips at the top and bottom.
- Release the connection to the reagent plug and reagent bottle.
- Pull the locking pins slightly forward. (The locking pins can only be pulled up and not out).
- Pull the drain plug, actuator plug and inlet plug out of the measuring chamber.
- Pull the measuring chamber to the right from the retaining bolts on the control housing.
- Remove the stirring blade.
- Use a flat-tip screwdriver to lever the reagent plug upwards. (Make sure that the locking pins are raised before levering.)
- Clean the measuring chamber and the plugs using the cleaning set as described on the package insert.

Please observe the following sequence when assembling:

- Lubricate O-rings (3 x J and 1 x C) with technical Vaseline.
- Pull up the locking pins Insert the reagent plug and lock it.
- Place the cleaned measuring chamber on the retaining bolts and lock.
- Insert the stirring blade into the measuring chamber.



- Pull up the locking pins Insert the inlet plug, actuator plug and drain plug into the measuring chamber and lock.  
(Make sure that all plugs are inserted into the measuring chamber up to the stop and only then locked, otherwise the plugs can be damaged).

Connect the hose pump cassette to the reagent plug and to the reagent bottle.

- Place the peristaltic pump cassette on the bracket so that it snaps into place.
- Switch the unit on again.
- Flush the measuring chamber (Programming: Menu > Service > Manual flush).
- Feed the reagent into the measuring chamber (Programming: Menu > Service > Pump reagent).

*Was a full reagent bottle used?*

Select [Yes] or [No] and press the [OK] key.

[Yes] The cylinder filling level is set to 100 %.

[No] The previous cylinder filling level in % is retained.

- Flush the measuring chamber again (Programming: Menu > Service > Manual flush).

The instrument is ready for operation again.

## 10.2 Inserting the “Maintenance set 02”

It is necessary to change the dosing-pump-cassette at regular intervals. This is included in the “maintenance set for analyzer”. The exchange takes about 10 minutes.

The hose pump cassette, hoses and seals must be replaced at regular intervals.

The required replacement parts are included in the "Maintenance set 02".

Maintenance takes about 25 minutes.

Proceed as follows:

- Switch off the device.
- Pull the hose pump cassette from the bracket by unlocking the clips at the top and bottom.
- Release the connection to the reagent plug and reagent bottle.

- Replace the bottle connector, the suction lance and the hose pump cassette.
- Pull the locking pins slightly forward. (The locking pins can only be pulled up and not out).
- Pull the drain plug, actuator plug and inlet plug out of the measuring chamber.
- Pull the measuring chamber to the right from the retaining bolts on the control housing.
- Remove the stirring blade.
- Use a flat-tip screwdriver to lever the reagent plug upwards. (When levering it out, make sure that the locking pins are raised).
- Pull up the locking pin for light rod plugs.
- Take a non-metallic object such as a plastic or wooden rod, insert it into the actuator plug hole and push out the light rod plug (The light rod stopper belongs to the optical measuring section and must not be scratched).
- Remove the O-rings (4 x J, 1 x C and 1 x D) from the plugs. See Spare parts illustration on page **Error! Bookmark not defined.**
- Clean the measuring chamber and the plugs using the cleaning set as described on the package insert.

Please observe the following sequence when assembling:

- Slide the O-rings onto the plugs (4 x J, 1 x C and 1 x D).
- Pull up the locking pin Insert the light rod plug and lock it.
- Pull up the locking pins Insert the reagent plug and lock it.
- Place the cleaned measuring chamber on the retaining bolts and lock.
- Insert the stirring blade into the measuring chamber.
- Pull up locking pins Insert inlet plug, actuator plug and outlet plug into the measuring chamber and lock.  
(Make sure that all plugs are inserted into the measuring chamber up to the stop and only then locked, otherwise the plugs can be damaged).
- Connect the hose pump cassette to the reagent plug and to the reagent bottle.
- Place the peristaltic pump cassette on the bracket so that it snaps into place.
- Switch the unit on again.
- Flush the measuring chamber (Programming: Menu > Service > Manual flush).
- Feed the reagent into the measuring chamber (Programming: Menu > Service > Pump reagent).

*Has a full reagent bottle been inserted?*

Select [Yes] or [No] and press the [OK] key.

[Yes] The cylinder filling level is set to 100 %.

[No] The previous cylinder filling level in % is retained.

- Flush the measuring chamber again (Programming: Menu > Service > Manual flush).

- Reset the maintenance counter to 24 months / 30,000 analyses.  
(Programming: Menu > Service > Confirm Maintenance).

The device is ready for operation again.

### 10.3 Reset the Maintenance Counter

After maintenance has been carried out with the "Maintenance set 02" inserted, the maintenance counter in IQ must be reset.

The message "Maintenance" disappears from the display and only appears after the 24 months have elapsed or after 30,000 analyses, then maintenance must be carried out again.

(Programming: Menu > Service > Confirm maintenance).

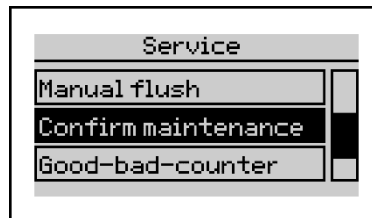

Select [Yes] or [No] with [◀] and [▶] and confirm with [OK] key.

[Yes] Maintenance counter is set to 30,000 analyses and the maintenance date is set to 24 months.

(Can be read in the Menu > Info)

[No] The device retains the previous data.

## 10.4 Changing the reagent bottle

First check the expiry date of the new reagent bottle. Use only the reagent whose shelf life has not been exceeded.

Proceed as follows:

- Switch off the device.
- To replace the reagent bottle, undo the screw cap on the bottle and insert the new reagent bottle. Absorb drip quantities if necessary.
- Switch the device on again.
- Flush the measuring chamber (Programming: Menu > Service > Manual flush).
- Feed the reagent into the measuring chamber (Programming: Menu > Service > Pump reagent) until the reagent reaches the measuring chamber free of bubbles. Then press the [OK] key to stop purging the reagent line.

*Has a full reagent bottle been used?*

Select [Yes] or [No] and press the [OK] key

[Yes] The bottle fill level is set to 100%.

[No] The previous bottle fill level in % is maintained.

- Flush the measuring chamber again (Programming: Menu > Service > Manual flush) to clean the measuring chamber.
- Test the analysis process by starting an analysis. To do this, hold down the [OK] key for 3 seconds in the measured value view.

The device is again ready for operation.

## 10.5 Good and Bad Counter

The good and bad counters are used to count the analysis results. They are displayed in the info screen.

Programming: Menu > Info

HARDWARE VERSION	09.02.2018
SOFTWARE VERSION	08.10.2018
ANALYSIS COUNTER	47
MAINTENANCE COUNTER	22404
MAINTENANCE DATE	28.09.2020
GOOD MEASURES	0
BAD MEASURE COUNTER	0

If the limit is exceeded, the bad counter is increased, and if the limit is undershot, the good counter is increased. This counter can be used to assess the function of a water softening system. Here, the number of bad measurements should be much smaller than that of the good measurements. The counters can be reset in the menu.

Programming: Menu> Service> Good-bad-counter

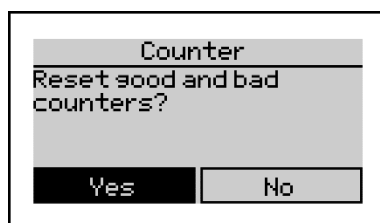

## 10.6 Calibrating the unit

The unit is calibrated at the factory at a room temperature of 20°C. If the unit is to be used in especially hot or cold environments, please re-calibrate when commissioning.

You can calibrate the unit as follows:

- Carry out analysis using the unit
- At the same time carry out an analysis in the laboratory (lab.)
- Calculate the correction factor for the unit with the following formula:

$$\text{Correction factor} = \frac{\text{Value(lab.)}}{\text{Test result}} \times 100\%$$

- Feed the correction factor into the unit via (Menu >Parameter>Analysis > Correction factor). To do this, it is necessary to give in the code word of the unit or assign a new code word via (Menu > General >Codeword).

## 10.7 Changing the Battery

If the unit does not show the time when it is switched of, it is necessary to change the back-up battery as follows:

- Switch off and disconnect the power from the unit.
- Open the control box by removing the 4 screws. The battery holder is found on the circuit board under the lid.
- Replace the battery with the type CR2032.
- Ensure that the ribbon cable between the 2 circuit boards has not come loose. Close the control box again.
- Dispose of the battery in a responsible way.

## 10.8 Software Update

The analyzer offers the option of a software update. As part of the product improvement, you will receive software updates via your dealer or our website. Should this be required, your dealer will send you a file called TA27xxx.bin.

To perform a software update, proceed as follows:

- Switch off the device and disconnect the power supply.
- Open the controller housing with 4 screws and remove the SD card.
- Copy the TA27xxx.bin file to the SD card using a computer and reinsert it.
- Close the controller again. Make sure that the connection cable between the reagent circuit board and the controller has not come loose.
- Hold down the [OK] key and turn on the power. When software update appears on the display, release the [OK] key. The device updates the software and finally starts measurement mode again.
- Turn off the device, remove the SD card, and delete the TA27xxx.bin file from the SD card.
- Insert the SD card back into the device.
- Check the device configuration of the device.



## 11 Diagnostics

Here, pay attention to possibly connected controllers and peripherals.

Follow the valid safety regulations.

Call up the following program function:

Programming: Menu> Service> Diagnostic program

### 11.1 Display

The display changes colour between red, green, and blue.

To exit, press the [OK] key.

### 11.2 Sensor

The LED in the measuring chamber is switched on and off. If this is not the case, check the electrical connection of the LED on the actuator plug and in the device. If the connectors are properly seated, the actuator must be replaced. To exit, press the [OK] key.

### 11.3 Solenoid Valve

The solenoid valve in the water inlet can be opened and closed via the [OK] key. If this is not the case, check the electrical connection of the solenoid valve in the device. If the connectors are properly seated, measure the voltage with "valve open" between the connections on the valve. This should be at 24 VDC. If this is the case, a fault in the electronics is to be excluded and the solenoid valve is defective.

To exit, move the cursor to Exit and press the [OK] key.

## 11.4 Reagent Pump

When starting the reagent pump, the peristaltic pump cartridge is driven for 2 seconds. Here, rotation of the rollers in the peristaltic pump cartridge is visible and the turning of the motor can be heard. If this is not the case, check the four-pole connection of the motor on the circuit board. If only the noise is noticeable, the peristaltic pump cartridge is defective. Otherwise, a fault of the motor or the control circuit board is possible. To exit, move the cursor to Exit and press the [OK] key.

## 11.5 Agitator Blade

The agitator blade in the measuring chamber is actuated and slowly increases its speed to the maximum. If the agitator blade does not turn, check the correct seating of the drive motor connector on the control circuit board (red plug connector).

Remove the measuring chamber and check whether the drive disc (which has two silver-coloured magnets) in the agitator does not drag or rest on the motor housing.

If none of these causes can be determined, the drive motor must be replaced. To exit, press the [OK] key.

## 11.6 Relay 1 and 2

When the diagnostic function relay is started, the selected relay is switched between the two contacts NC and NO via the [OK] key.

Use a continuity tester to check the contact between the COM and NC connection and COM and NO connection. If the switching operations are not measurable, replace the control circuit board.

To exit, move the cursor to Exit and press the [OK] key.

## 11.7 Current Interface

An ammeter is required to test the current interface. Measurements are made between terminals 15 (+) and terminal 16 (-).



The output current is shown in the display as I = xx mA. The same value should also be measured at the two terminals. Tolerance  $\pm 0.3$  mA. Please note the accuracy of your current ammeter.

Pressing the [OK] key increases the output current by 2 mA respectively, until the maximum value of 20 mA is reached. To exit, move the cursor to Exit and press the [OK] key.

## 11.8 Input

To test the input, you will need a ladder or multimeter that is set for continuity testing.

If there is no jumper between terminals 17 and 18, the display shows "opened".

If a jumper is set between terminals 17 and 18, the display shows "closed".

*(If you wish to make the jumper with a multimeter, the COM port of the multimeter must be connected to terminal 17 and the Volt port of the multimeter must be connected to terminal 18. Otherwise, no bridge will be made by the multimeter)*

Press the [OK] key to exit.

The diagnostic mode has ended.

## 12 Error Analysis

### 12.1 Error messages

#### Error message E11 indicator

After the first dosing of the analysis, no sufficient discoloration was detected in the sample.

- Check whether there is still enough indicator in the indicator bottle.
- Check the connecting tube between the indicator bottle and the peristaltic pump for air bubbles. If necessary, pump indicator until the hose is filled with indicator.
- Check whether there is water in the measuring chamber.
- Check the dosing pump and agitator assemblies.
- Check that the water drain is clear and that no foreign bodies have become lodged in the solenoid valve.
- When using a pump for sample delivery, check that the pump is connected correctly.
- Check that the inlet and outlet are connected the right way round.
- Check that the stirring blade is in the measuring chamber.
- 0mA is output at the current output if the type "value" is set at the current interface.

#### Error message E12 Water flow

The measuring chamber is not rinsed with clear water after the end of the analysis. The sensor does not detect any lightening of the measuring chamber due to rinsing.

- Check whether there is line pressure at the unit connection.
- Check the function of the solenoid valve.
- Check if the drain is clogged.
- If necessary, check the function of the sample pump, stopcocks, and valves.
- 0mA is output at the current output if the type "value" is set at the current interface.

#### Error message E13 Optics

No difference in brightness was detected after switching on the actuator LED.

- Check the measuring chamber for dirt.
- Check the electrical connection of the actuator plug.
- Check the correct position of the actuator plug.
- Check the color sensor in the diagnostic menu.

- 0mA is output at the current output if the type "value" is set at the current interface.

#### **Error message E14 Titration**

During titration, the color change in the measuring chamber is too weak. Too little indicator is dosed.

- Check whether there is still enough indicator in the indicator bottle.
- Check the connecting tube between the indicator bottle and the peristaltic pump for air bubbles. If necessary, pump indicator until the hose is completely filled with indicator.
- Check that the inlet and outlet are connected the right way round.
- Check that the programmed indicator type matches the one used.
- Check that the water drain is clear and that no foreign bodies have become lodged in the solenoid valve.
- Check the function of the dosing pump.
- Check the dosing plug and indicator tubes for foreign objects.
- Check that the blue O-ring on the dosing plug is present and properly seated.
- 0mA is output at the current output if the type "value" is set at the current interface.

## **12.2 Fault finding**

### **The analysis will not begin**

- Check that the flow meter is correctly configured and connected.
- Check that the interval time is set.
- Check whether a water meter is connected and correctly configured.
- Check, if relevant, connections from an external controller.

### **Error during the blank test**

- Check that there is water in the chamber and that the supply and waste pipes are not swapped.
- Check the chamber for dirt, gas bubbles or foreign bodies.
- Check the water pressure (recommended 1-2 bar).
- Check that the waste pipe is free and that there are no foreign bodies in the magnet valve.
- If a pump is used to supply the sample water, ensure that it is correctly connected.

- With the help of the diagnosis menu, check the function sensor and magnet valve.

**Error during Titration**

- Check that there is enough reagent available.
- Check the pipes between the reagent bottle and the dosing-pump for air bubbles. If necessary, pump reagent until the pipes are full of reagent.
- Check that the blue O-ring is still on the nozzle of the dosing-plug.
- Check that there is water in the chamber.
- Check that there is a magnetic stirrer (stir-fish) in the chamber.
- Check the reagent delivery, the sensor and the stir-fish with the diagnosis menu.

**False test result**

- Check that the reagent corresponds to that programmed.
- Check for air bubbles in the reagent delivery pipe.
- During the blank test, check that the sample water is not coloured by foreign substances, sediment or air bubbles.
- Check that there is water in the chamber and that the supply and waste pipes are not swopped.
- Check that there is a magnetic stirrer (stir-fish) in the chamber.
- Check that the blue O-ring is still on the nozzle of the dosing-plug and that it is positioned correctly.
- Check that the magnet valve closes properly.
- Exchange the reagent pump-cassette
- Re-calibrate the unit with a new correction factor.

### 13 Spare parts

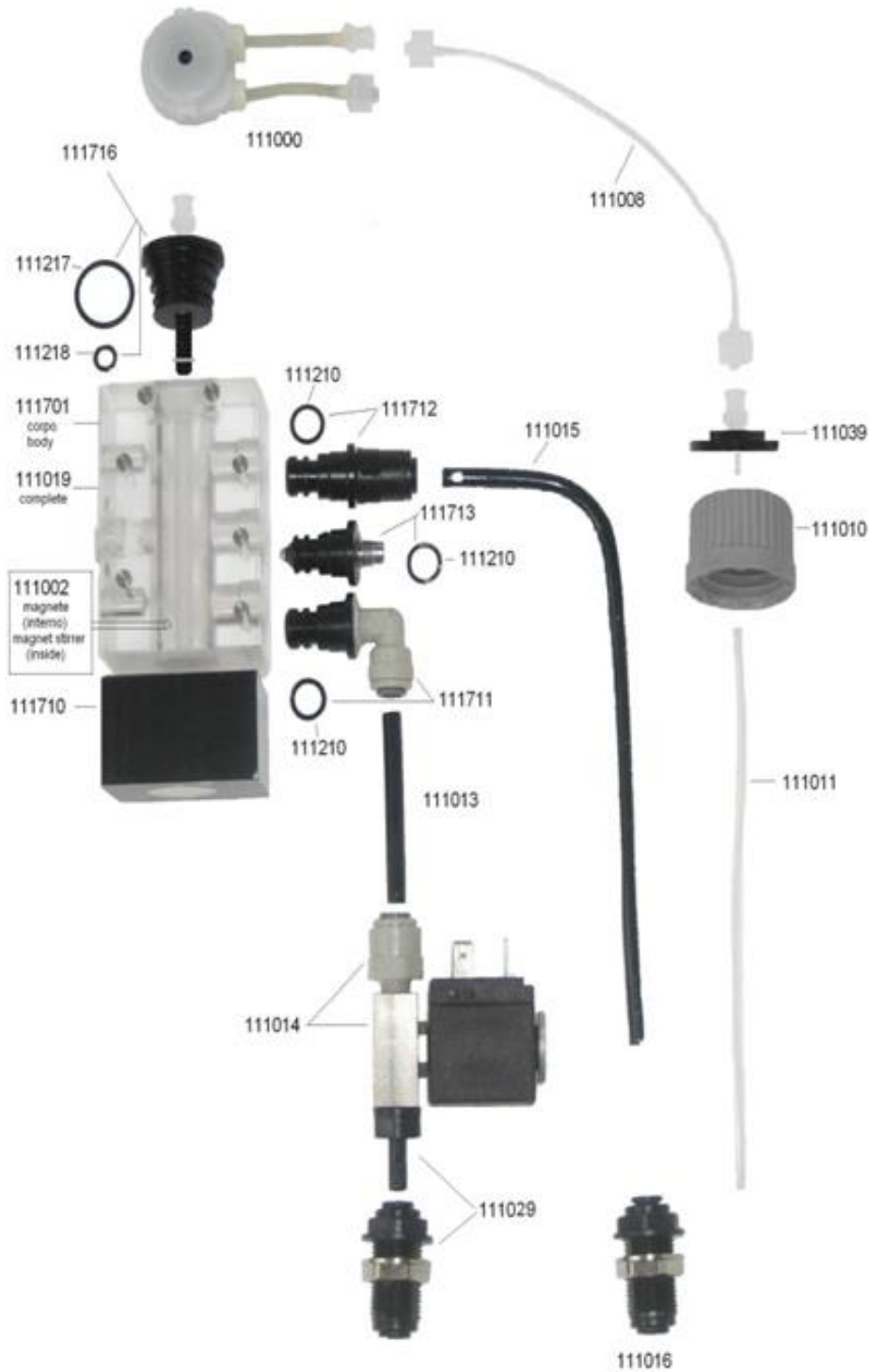



Article nº	Description	Part Number
111 002	Magnetic stirrer	W6050-002
111 008	Bottle connector	W6050-008
111 009	Bottle adapter	W6050-009
111 011	Suction lance	W6050-011
111 060	Bottle cap	W6050-060
111 013	Inlet pipe ¼"	W6050-013
111 014	Magnet valve 24V complete	W6050-014
111 015	Outlet pipe 6mm	W6050-015
111 016	Connector 6mm water outlet	W6050-016
111 029	Connector 6mm water inlet	W6050-029
111 727	Actuator for magnetic stirrer 12V complete.	W6050-727
111 210	O-Ring	W6050-210
111 217	O-Ring	W6050-217
111 218	O-Ring	W6050-218
111 000	Dosing-pump cassette	W6050-000
111 700	Measuring-chamber complete (33-090002,33-090701,33-090711,33-090712,33-090713,33-090716+ O-rings)	W6050-700
111 701	Body of measuring-chamber	W6050-701
111 711	Inlet plug 6mm	W6050-711
111 712	Outlet plug 6mm	W6050-712
111 713	Actuator plug (LED)	W6050-713
111 716	Dosing plug	W6050-716
<b>Spare Not Shown In Picture</b>		
111 020	Cable for magnet valve	W6050-020
111 021	Cable for Actuator(LED)	W6050-021
111 023	Power supply board 85-264 V	W6050-023
	Control box case (with lid)	
111 028	Dosing-pump complete	W6050-028
	Control board complete	
	Display board complete	
111 911	<b>O-Ring Set Complete</b> (1x 111217, 3x 111210, 1x 111218)	W6050-911
111 906	<b>Maintenance Set 02</b> (1x 111000 Dosing pump cassette, 1x 111008 Bottle connector, 1x 111011 Suction Lance, 1x 111217 O-ring, 3x 111210 O-ring, 1x 111218 O-ring)	W6050-906

<b>Recommended Spare parts for 2-3 years</b>		
1x 111727	Actuator for magnetic stirrer	1x W6050-727
1x 111014	Magnet valve 24V	1x W6050-014
1x 111700	Measuring chamber complete	1x W6050-700
1x 111028	Dosing pump complete	1x W6050-028
4x 111906	Maintenance set 02	4x W6050-906

## 14 Maintenance Sets

The 6051 is largely maintenance-free. A maintenance set is available for the analyzer. It is recommended to change the hose pump cassette, hoses and O-rings after 30,000 analyses or 24 months. At the end of the maintenance interval, the instrument displays a maintenance note on the display. The maintenance counter must be reset or confirm after maintenance has been carried out.

In addition, it is recommended to clean the measuring chamber regularly, but at least every 6 months. The cleaning set is offered for this purpose. It contains all the aids required for cleaning as well as the cleaning fluid.

Article		Order number
Maintenance set for the 6051		W6050-906
Cleaning set for the 6051 Cleaning set for the chamber		Road transport: W6050-213  Air transport: W6050-213S



## 15 Measurement Range of Our Reagents

### Reagents for water hardness (500ml):

Order number	Type	Range of measuring		
		°f	°dH	ppm
W1234-455	500S/500	0,022-0,21°f	0,012-0,12°dH	0.22-2.14 ppm
W1234-456	500/500	0,04 - 0,36°f	0,02-0,2 °dH	0.36-3.56 ppm
W1234-457	501/500	0,05-0,54°f	0,03-0,3°dH	0.53-5.34 ppm
W1234-458	502/500	0,11-1,07°f	0,06-0,6°dH	1.07-10.68 ppm
W1234-459	503/500	0,16-1,61°f	0,09-0,9°dH	1.60-16.02 ppm
W1234-460	505/500	0,27-2,68°f	0,15-1,5°dH	2.67-26.70 ppm
W1234-461	510/500	0,54-5,36°f	0,3-3,0°dH	5.34-53.40 ppm
W1234-462	520/500	1,07-10,71 °f	0,6-6,0°dH	10.68-106.8 ppm
W1234-463	530/500	1,61-16,07°f	0,9 - 9,0°dH	16.02-160.2 ppm
W1234-464	550/500	2,68-26,79°f	1,5-15°dH	26.70-267.0 ppm
W1234-465	600/500	5,36-53,57°f	3,0-30°dH	53.4-534.0 ppm
<b>Carbonate hardness</b>				
W6050-C710	C-710/500	0,54-5,36°f	0,3-3,0°dH	5.34-53.4 ppm
W6050-C715	C-715/500	0,80-8,04°f	0,45-4,5°dH	8.01-80.1 ppm
W6050-C720	C-720/500	1,07-10,71°f	0,6-6,0°dH	10.68-106.8 ppm
W6050-C730	C-730/500	1,61-16,07°f	0,9-9,0°dH	16.02-160.2 ppm



## 16 Calculation Table for Common Units of Water Hardness

		<b>°dH</b>	<b>°e</b>	<b>°f</b>	<b>ppm</b>	<b>mval/l</b>	<b>mmol/l</b>
<b>German Hardness</b>	1 °dH =	1	1.253	1.78	17.8	0.357	0.1783
<b>English Hardness</b>	1 °e =	0.798	1	1.43	14.3	0.285	0.142
<b>French Hardness</b>	1 °fH =	0.56	0.702	1	10	0.2	0.1
<b>ppm CaCO<sub>3</sub> (USA)</b>	1 ppm =	0.056	0.07	0.1	1	0.02	0.01
<b>mval/l Earth alkali</b>	1 mval/l =	2.8	3.51	5	50	1	0.5
<b>mmol/l Earth alkali</b>	1 mmol/l =	5.6	7.02	10	100	2	1



## **17 Instructions for Disposal**

- Do not dispose of the unit in household rubbish.
- The unit should be taken to a certified collection point for electrical devices.
- The battery must be disposed of separately.

The unit can also be returned to the dealer or manufacturer for proper disposal.