



EXPERTS IN WATER CHEMISTRY SINCE 1903



**9135 Sodium Analyzer
User Manual**



Waltron Customer Commitment

This user manual is a technical guide to aid the customer in the setup and maintenance of their new Waltron measuring system. Waltron provides continuous product improvement and reserves the right to make any modifications to the information contained herein without notice.

**Copyright © Waltron Bull & Roberts, LLC, 2024
All Rights Reserved**

Technical questions concerning this product should be addressed to:

Waltron Technical Service Department

25 Minneakoning Rd, Suite 101

Flemington, New Jersey 08822

Phone: +1 908 534 5100, option 3 **Fax:** +1 908 534 5546

www.waltron.net

Please be ready to provide the following information:

- The date analyzer was purchased.
- Analyzer model and serial number.
- Recent maintenance history.
- Calibration slope values and a detailed description of the problem.

Waltron's technical expertise and extensive experience provide personalized solutions to the water quality industry. It is Waltron's commitment to provide the customer with timely and accurate technical service and support.

Waltron fully expects the customer to be satisfied with the quality, performance, and cost of this product. If there are any questions or concerns regarding this product, please feel free to contact Waltron.

Thank you for choosing Waltron!

Please note Waltron mailing and UPS shipping addresses:

DIRECT ALL CORRESPONDENCE AND SHIPMENTS TO:

Waltron Bull & Roberts, LLC
25 Minneakoning Rd, Suite 101
Flemington, NJ 08822



Safety

Please observe proper safety and handling precautions when installing, operating, maintaining, and servicing this product. The following should be noted and adhered to:

- ✓ Read and understand the manual before working with the analyzer.
- ✓ Pay special attention to warning labels on enclosures, containers, packages, and chemicals.
- ✓ Only qualified personnel should be involved in the installation, operation, and servicing of the analyzer.
- ✓ Follow safety precautions when operating the analyzer in conditions of high pressure and/or temperature.
- ✓ Keep analyzer chemicals away from heat and extreme temperatures. Reagent powders must be kept dry.
- ✓ Follow all regulations and warning labels when disposing of chemicals. Do not mix chemicals.

*To obtain analyzer safety information or **Safety Data Sheets (SDS)**, please contact Waltron or visit www.waltron.net.*



Warranty Agreement

If, within one year from the date of shipment, the customer experiences any equipment defects or is not satisfied with the analyzer manufacturing, Waltron will repair or, at its option, replace any defective part(s) free of charge. This warranty requires that the defective part(s) be returned to Waltron with shipping charges prepaid.

At Waltron's discretion, a Technical Service Specialist may be sent out to repair or replace the defective part(s) on location. The traveling time and expenses of the Technical Service Specialist are at the customer's expense.

Equipment sent to Waltron must be appropriately packaged, and the following information must be provided prior to returning to Waltron:

- ✓ The Return Authorization (RA) number is assigned to the customer by the Waltron Technical Service Department.
- ✓ Customer name, address, and department.
- ✓ Name and telephone number of the individual responsible for returning items for repair.
- ✓ Brief problem description.

Ship to Waltron Service Center:

Waltron Bull & Roberts, LLC
25 Minneakoning Rd, Suite 101
Flemington, NJ 08822



Checklist of Materials

In order to ensure customer satisfaction, Waltron does its best to provide adequate and timely packaging and shipping services. Please perform the following after receiving a shipment:

- ✓ Inspect all shipping containers upon receipt and record any visible damage. If there are any outward signs of damage, please retain all containers and packages for inspection by the carrier. Please retain all packing material so that it can be used for future moving and shipping needs.

- ✓ Check all items received against those on the packing list. Chemicals are usually shipped in a separate package and will be itemized accordingly.

- ✓ Verify that the number of packages received agrees with the packing list and shipping papers.

- ✓ Notify both Waltron and the carrier if any problems occur.

Important Notice

- ✓ All monitors are inspected and tested prior to shipment.
- ✓ In normal use, the unit should require only minor maintenance and should operate correctly and without fault over a long period of time.
- ✓ Please note that if electronic components need to be replaced, it may be necessary to adjust and/or calibrate the monitor.
- ✓ Failure to carry out correct maintenance procedures may result in inaccurate monitor readings.



Table of Contents

| | |
|---|-----------|
| 1 INTRODUCTION | 8 |
| 1.1 GENERAL | 8 |
| 1.2 MAIN FEATURES | 8 |
| 1.3 SYSTEM DESCRIPTION & ARCHITECTURE | 9 |
| 1.3.1 WET SECTION UNIT | 10 |
| 2 INSTALLATION | 12 |
| 2.1 MOUNTING OF ANALYZER | 12 |
| 2.1.1 LOCATION AND LAYOUT | 12 |
| 2.2 SAMPLE REQUIREMENTS | 13 |
| 2.3 EXTERNAL PIPING CONNECTIONS | 13 |
| 2.4 ELECTRODE INSTALLATION | 14 |
| 2.4.1 PROBE CONNECTIONS | 14 |
| 2.4.2 GEL FILLED REFERENCE ELECTRODE (ALTERNATE) | 15 |
| 2.4.3 AUTOMATIC KCL REFILL SYSTEM (OPTIONAL) | 16 |
| 2.4.4 PROBE INSTALLATION PROCEDURES | 17 |
| 3 OPERATING THE ANALYZER | 19 |
| 3.1 ANALYZER OPERATION | 19 |
| 3.2 ALARMS | 21 |
| 3.3 GETTING STARTED | 21 |
| 3.4 SOFTWARE PROGRAMMING | 21 |
| 3.4.1 SOFTWARE STRUCTURE MAP | 22 |
| 3.4.2 MAIN MENU – USER MODE | 22 |
| 3.4.3 COMMANDS WINDOW | 23 |
| 3.4.4 DISPLAY WINDOW | 28 |
| 3.4.5 MAIN MENU – SERVICE MODE | 33 |
| 3.4.6 SERVICE MENU | 36 |
| 3.4.7 AUTO CALIBRATION | 38 |
| 3.4.8 CALIBRATION FAILURE | 38 |
| 4 TROUBLESHOOTING – CALIBRATION FAIL | 39 |
| 5 MAINTENANCE | 40 |
| 5.1 BUFFER SOLUTION(S) | 40 |
| 5.2 STANDARD SOLUTIONS | 41 |
| 5.3 ETCHING SOLUTION | 41 |
| 5.4 REFERENCE ELECTRODE FILL SOLUTION (For Use with N3010-174) | 41 |
| 5.5 SCHEDULED SERVICING | 42 |



| | |
|--|-----------|
| 5.5.1 WEEKLY | 42 |
| 5.5.2 MONTHLY | 42 |
| 5.6 SHUT-DOWN PROCEDURE - (Prolonged Shut-Down, 1+ months) | 44 |
| 5.6.1 STORAGE OF ELECTRODES | 44 |
| 5.7 pH EFFECTS | 44 |
| 6 SPARE PARTS | 45 |
| 7 TROUBLE-SHOOTING | 47 |
| 8 SPECIFICATIONS | 50 |
| 9 APPENDIX | 51 |



1 INTRODUCTION

1.1 GENERAL

The Waltron 9135 Sodium Analyzer is a microcontroller-based unit used for online measurement of sodium content in various water chemistry/treatment applications. Sampling points for power generation include mixed bed outlets, extraction pump discharge, boiler feed, boiler drum, and steam. The measurement range of the 9135 analyzer spans from 0.01 ppb to 10 ppm.

1.2 MAIN FEATURES

Features of the 9135 Sodium Analyzer unit include:

1. Measurement of sodium concentration
 - o Wide range analysis - 0.01ppb to 10ppm. Concentration and temperature are displayed continuously, and the analyzer adjusts automatically to the user-specified ranges.
 - o Automatic temperature compensation
 - o Protection from “Hot Sample”
 - o Grab sample measurement
 - o Missing sample flow switch
2. Calibration
 - o Single & Two Point calibration
 - o Process calibration
 - o Fully automatic calibration (single & two-point)
 - o Low reagent and standard consumption
 - o Internal diagnostics used to show probe status
3. User Interface
 - o 4.5” color touch screen HMI
 - o Large, easy-to-read graphic display
4. Communication Interface via RS-485 using MODBUS RTU protocol
5. Analyzer Configuration:
 - o User configurable settings for recorder outputs and alarm set points
 - o Factory defaults can easily be reloaded to override user settings
6. Automatically stores the last 10 calibration and alarm logs.
7. Complete analyzer diagnostics
8. 3 Relay outputs for High, Low, and General Alarm
9. Two 4-20mA isolated current outputs
10. Quick connect electrodes with probe positioning clamps
11. Redesigned the drain for easy sample pH measurement
12. Automatic KCl refill system (optional)

1.3 SYSTEM DESCRIPTION & ARCHITECTURE

The 9135 Sodium analyzer system is comprised of the following:

1. Wet-Section (Sensor Unit)
 - a. Reagent solution containers
 - b. Hydraulic panel consisting of constant head, flow cell, tubing, thermistor, and 3 solenoid valves
 - c. Sodium and reference electrodes
 - d. 2 sodium standard solution containers (CAL1 and CAL2)
 - e. Grab a sample bottle

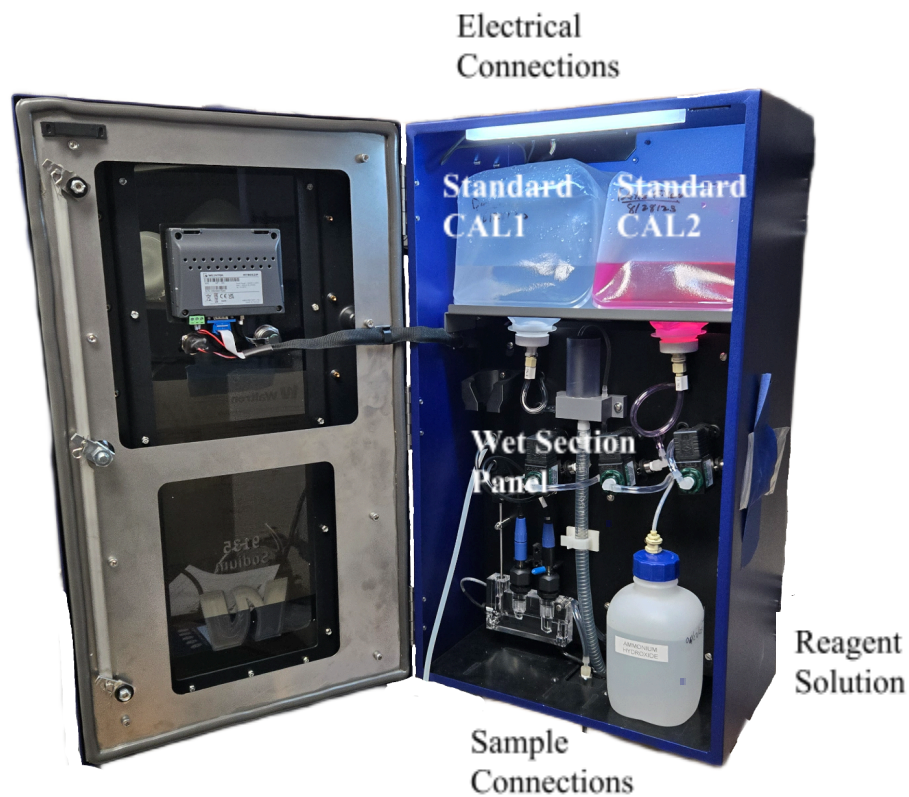

Figure 1. Overall system architecture.

1.3.1 WET SECTION UNIT

The 9135 Sodium system is capable of monitoring sodium concentrations in sample feed. Three solenoid valves are used to select between analyzing the sample, calibration solution 1 (CAL1), calibration solution 2 (CAL2), and grab sample.

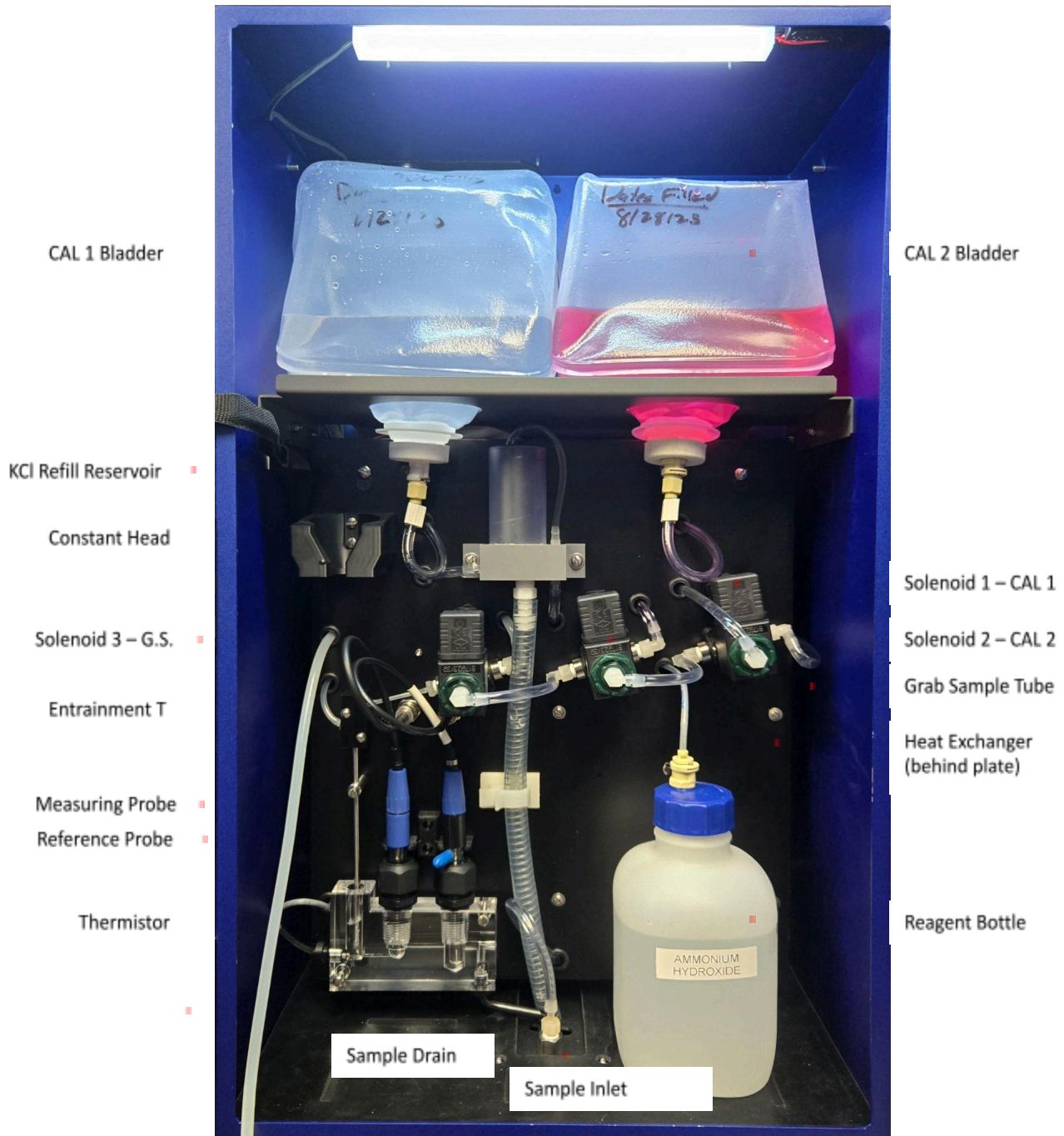
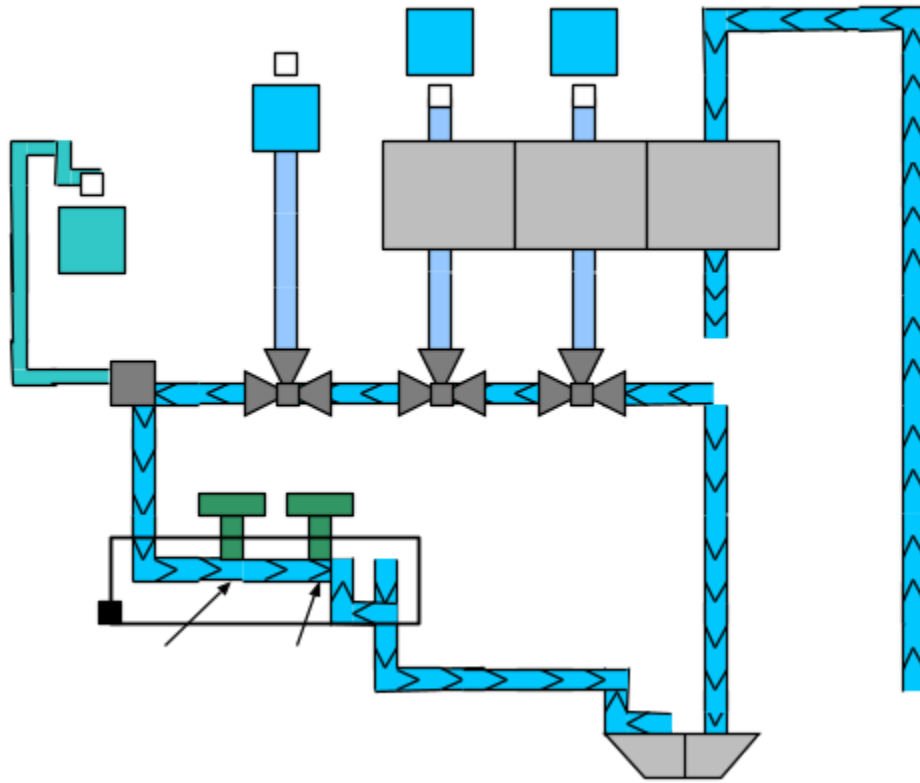

Figure 9. The wet section layout and connections.



Sample Inlet
Heat Exchanger
Solenoid 1
Constant Head Unit
Solenoid 2
Solenoid 3
Flowcell
Reference Electrode

Measuring Electrode
Thermistor
Entrainment "T"
Reagent Bottle
High Calibration Bladder
Grab Sample Bottle
Low Calibration Bladder
Overflow Drain
Waste Drain

Figure 2. Sample flow during normal operation.

2 INSTALLATION

2.1 MOUNTING OF ANALYZER

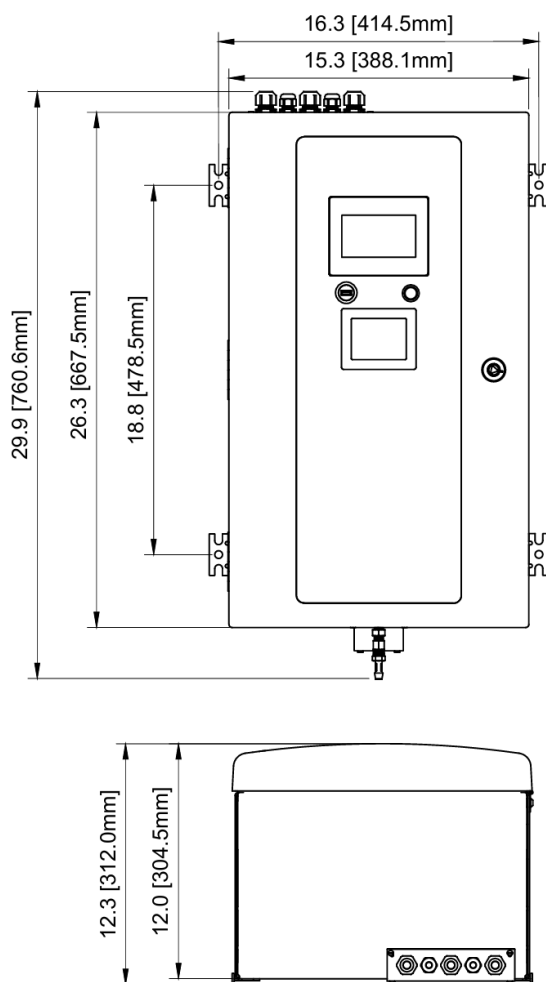

Figure 3. Dimensions to mount the Wet Section (All dimensions in inches).

2.1.1 LOCATION AND LAYOUT

Mount the analyzer in a clean, vibration-free area, avoiding direct radiant heat, sunlight, and drafts. Avoid areas containing chlorinating equipment. The 9135 Sodium analyzer default design has the two main sections (transmitter and wet section) combined as a single unit. If necessary, the sensor unit can be mounted separately as long as it is no more than 330 feet (100meters) from the transmitter unit.

2.2 SAMPLE REQUIREMENTS

The maximum sample pressures and temperatures specified in the SPECIFICATION section should not be exceeded. The sample should be introduced to the system at a temperature and pressure suitable for measurement. If necessary, the customer may choose to use sample cooling and pressure-reducing equipment. **It is highly recommended that a flow meter be installed at the sample inlet stream to ensure that the sample flow rate is within the specified range.** When pressure-reducing equipment is being used, a pressure relief valve should be installed between the sample point and sample inlet to ensure maximum safety.

2.3 EXTERNAL PIPING CONNECTIONS

Sample Inlet
 $\frac{1}{4}$ " ID
 Swagelok

Sample Overflow
 Drain
 Outlet $\frac{3}{8}$ " ID



Figure 5. The bottom of the wet section case, with the sample inlet and drain connections shown.

2.4 ELECTRODE INSTALLATION

2.4.1 PROBE CONNECTIONS

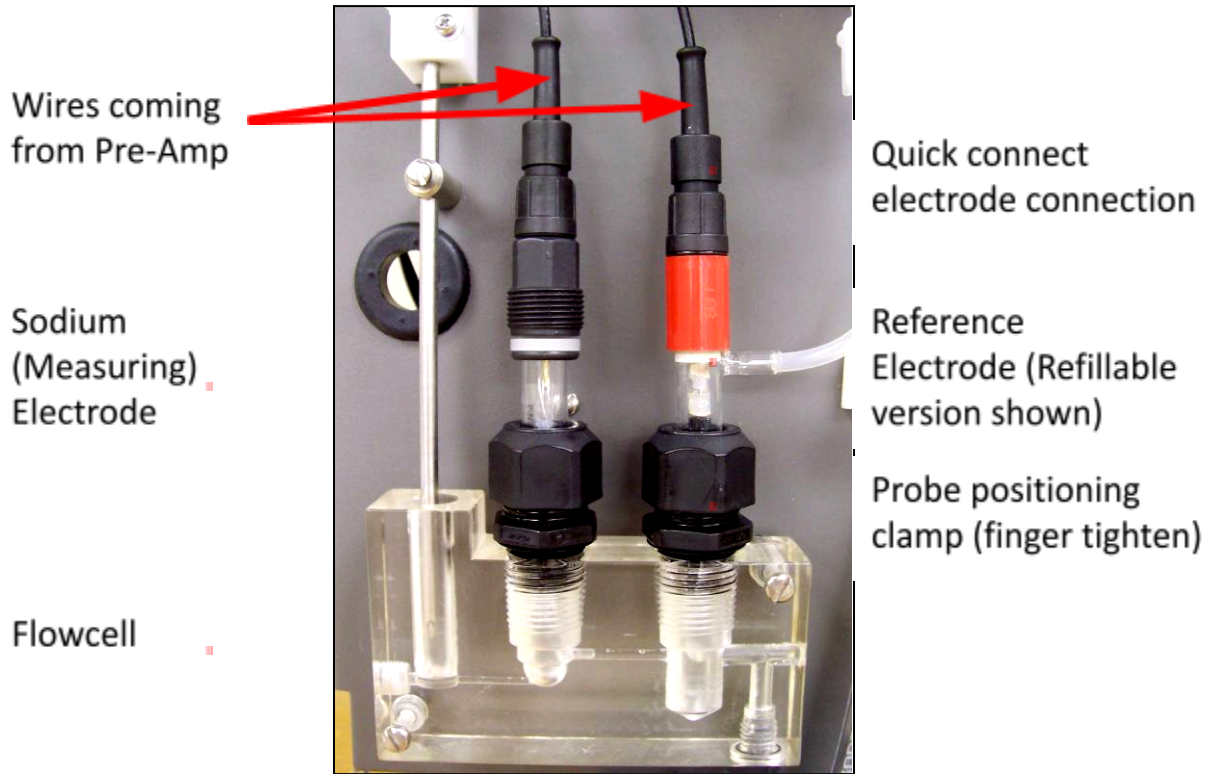
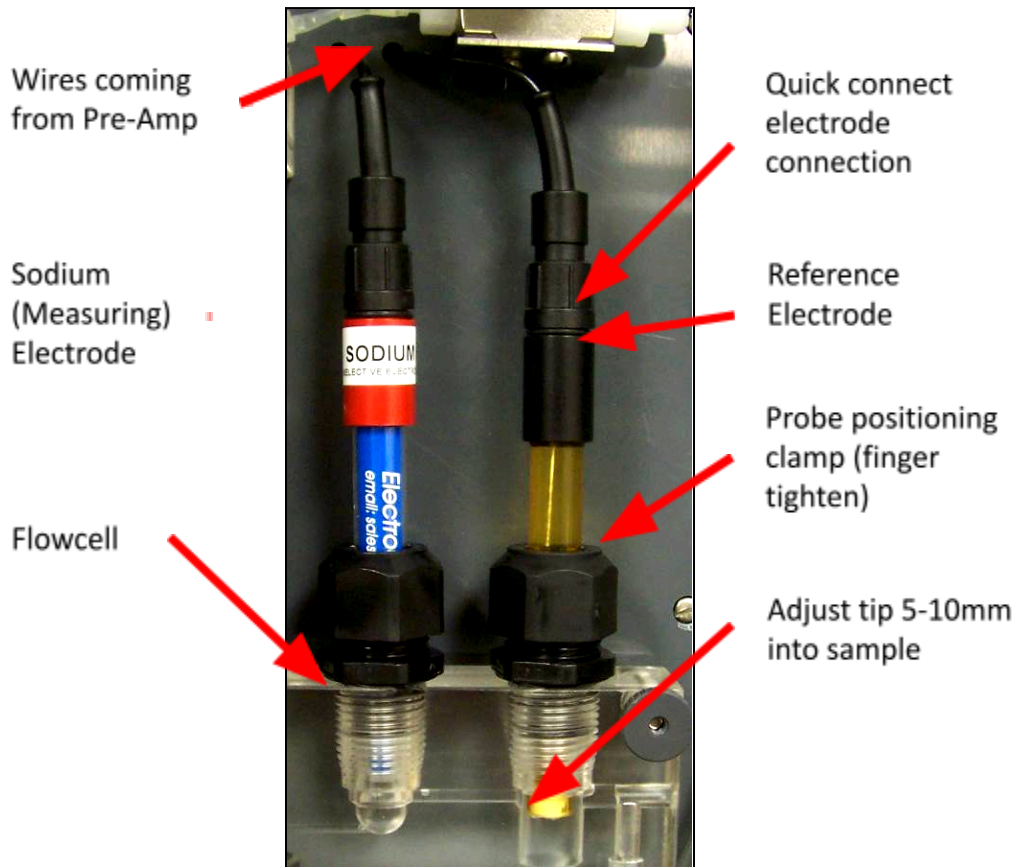

Figure 6. Placement of electrodes in the flowcell.

2.4.2 GEL FILLED REFERENCE ELECTRODE (ALTERNATE)



The gel-filled reference electrode has an inner element consisting of a gel solution that does NOT require electrolyte refilling.

2.4.3 AUTOMATIC KCL REFILL SYSTEM (OPTIONAL)

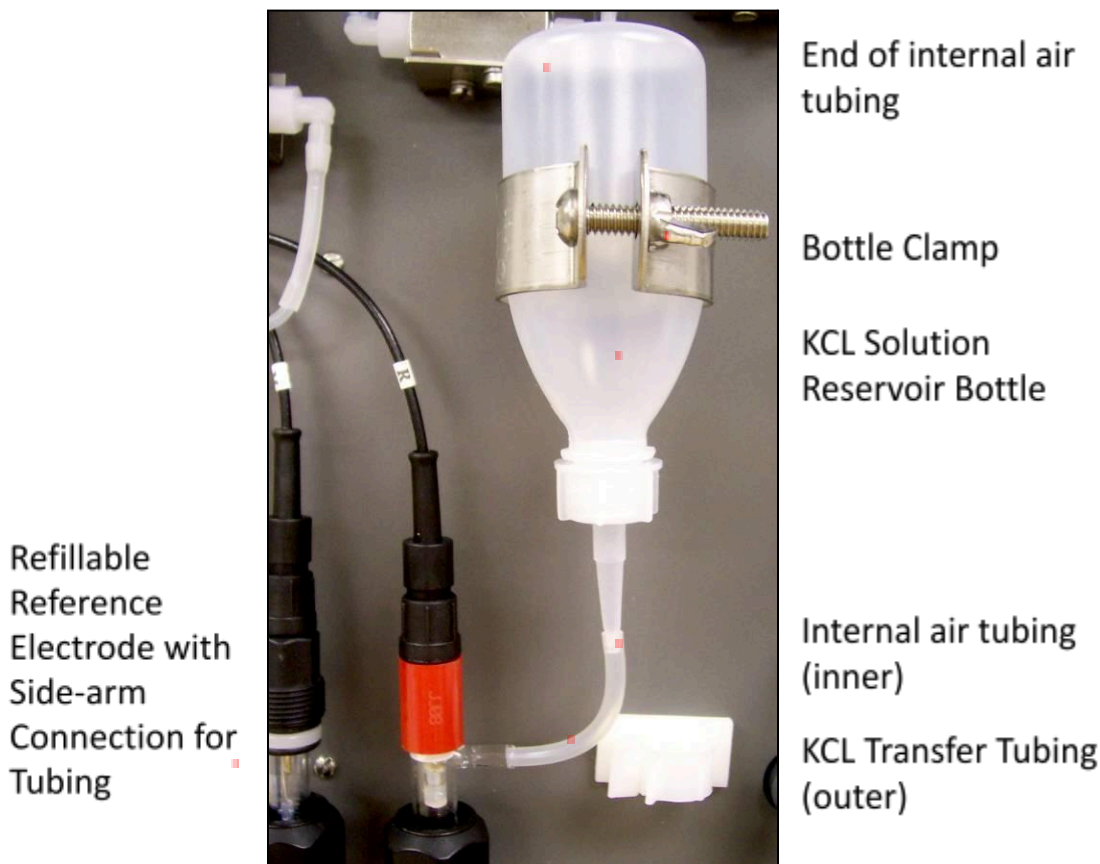

Figure 7. Layout of the Automatic KCl Refill System.

Directions for installing and using the KCl refill system:

1. Feed inner (smaller diameter) tubing through outer (larger diameter) tubing.
2. Feed inner tubing through the side-arm of the reference electrode and connect the outer tubing over the side-arm.
3. Clip the nozzle of the KCl bottle, making sure the hole is large enough for the inner tubing to pass through and that KCl solution can flow freely around it.
4. Insert inner tubing through the nozzle of the bottle and connect outer tubing over the nozzle of the bottle. Make sure the inner tubing reaches the top of the bottle while the other end remains inside the reference electrode.
5. Install the KCl bottle into the bottle clamp and finger-tighten the wing nut to hold the bottle in place.
6. Poke a small hole in the top of the bottle so KCl flows freely and a vacuum does not form.
7. Rinse off any spilled KCl with DI water before installing the probe in the flow cell. (KCl will interfere with sample reading if it gets in the flow cell.)

2.4.4 PROBE INSTALLATION PROCEDURES

1. Remove the protectors from the tip of each electrode
2. Connect electrodes to wires from the pre-amplifier. Be sure to match the correct wires to the correct probe. Wires are marked "M" for measuring and "R" for Reference.
3. Use fingers to rotate the probe positioning clamp counterclockwise to loosen. Carefully insert the electrode through the clamp and into the flow cell. Electrodes may have to be inserted at an angle.
4. For reference electrode - insert the electrode so that the tip of the electrode is 5 mm into the sample. Correct placement within the flow cell is important. Refer to the figure below.
5. For measuring electrode – insert the electrode so that the tip is just off the bottom of the flow cell. Refer to the figure below.

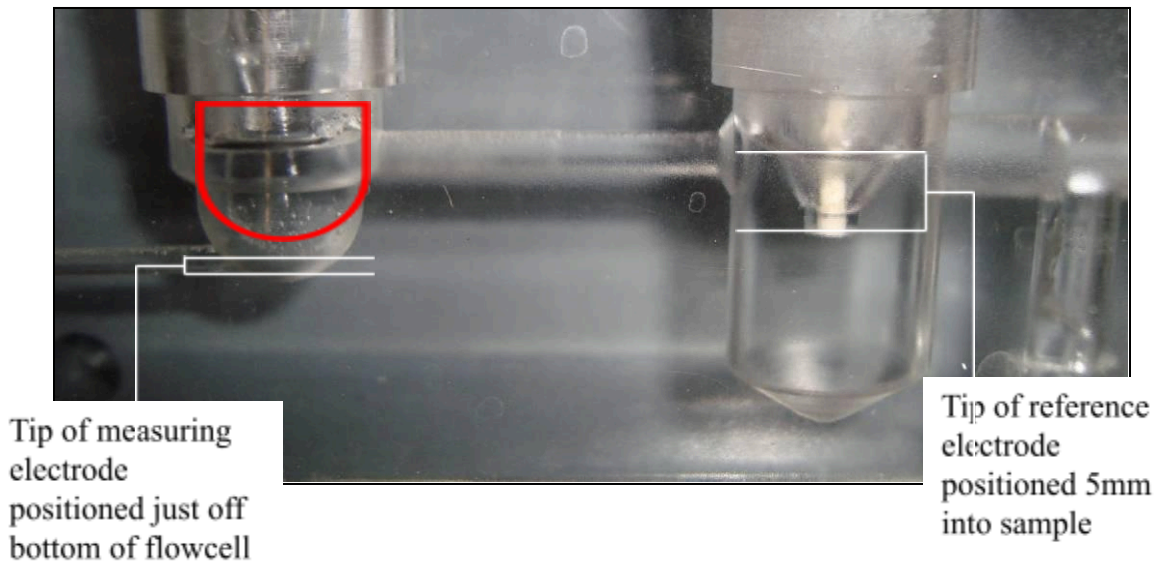

Figure 8. Proper installation of the Electrodes in the flow cell.



2.5 ELECTRICAL CONNECTIONS

| Cable Color | Pin | O/P Function | Signal |
|--------------|-----|--------------|---------------------------|
| Brown | 1 | CH 1 AO + | 0-10V / 4-20mA |
| Blue | 2 | CH 2 AO + | 0-10V / 4-20mA |
| White | 3 | CH 1&2 - | Gnd Return 0-10V / 4-20mA |
| Green | 4 | | Not Connected |
| Black | 5 | | Not Connected |
| Gray | 6 | | Not Connected |
| Red | 7 | Relay 1 | Normally Open |
| Violet | 8 | Relay 1 | Common |
| Gray/Pink | 9 | Relay 1 | Normally Closed |
| Red/Blue | 10 | Relay 2 | Normally Open |
| White/Green | 11 | Relay 2 | Common |
| Brown/Green | 12 | Relay 2 | Normally Closed |
| White/Yellow | 13 | Relay 3 | Normally Open |
| Yellow/Brown | 14 | Relay 3 | Common |
| White Gray | 15 | Relay 3 | Normally Closed |
| | 16 | | Not Connected |
| | 17 | | Not Connected |

| Cable Color | Pin | Line Power Description | Control PCB |
|-------------|-----|------------------------|-------------|
| Brown | 1 | Live | J3 - 1 |
| Black | 4 | Ground/Earth | J3 - 2 |
| Blue | 3 | Neutral | J3 - 3 |

3 OPERATING THE ANALYZER

3.1 ANALYZER OPERATION

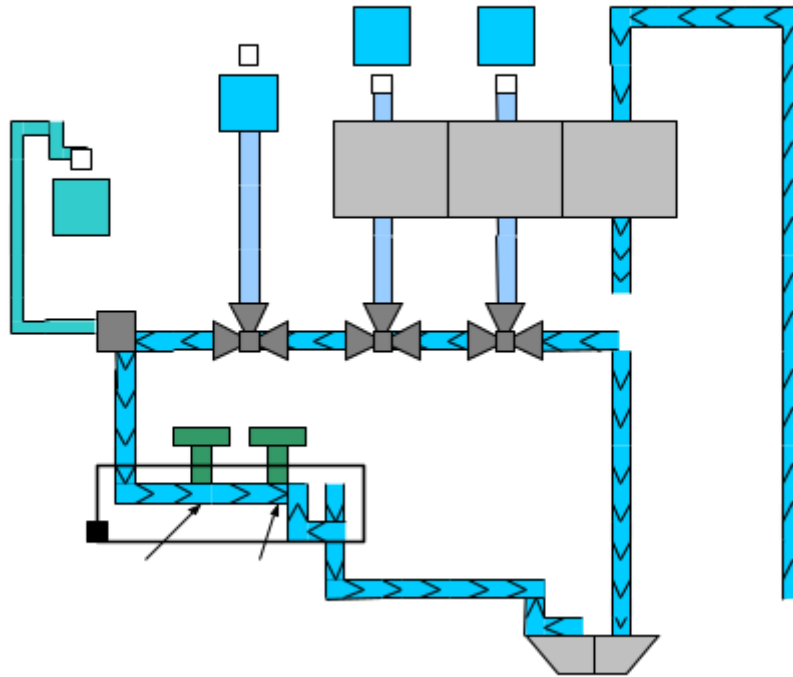

- Sample Inlet
- Heat Exchanger
- Solenoid 1
- Constant Head Unit
- Solenoid 2
- Solenoid 3
- Flowcell
- Reference Electrode

- Measuring Electrode
- Thermistor
- Entrainment "T"
- Reagent Bottle
- High Calibration Bladder
- Grab Sample Bottle
- Low Calibration Bladder
- Overflow Drain
- Waste Drain

Figure 15. Sample flow during normal operation.



The 9135 Sodium analyzer system is comprised of a stainless steel backplate. The internal hydraulic components and pipework are mounted directly onto the metal backplate. Sample enters through the inlet compression fitting at the bottom of the case and first passes through the sample flow switch before going to the heat exchanger. The heat exchanger is used to keep the sample temperature and the calibration solutions' temperature at equilibrium during calibration. Drastic and sudden changes in solution temperature may have a negative effect on electrode performance.

After flowing through the heat exchanger, the sample passes through a constant head (the constant head unit stabilizes the effect of changes in sample inlet flow rate) and then through the 3 solenoid valves. After the flow passes through the third solenoid valve (valve furthest to the left), it is then delivered to the entrainment 'T' where an alkaline vapor buffer is added to the sample in order to raise the pH value. After the sample and vapor reagent are mixed, the solution is sent to the flow cell where it comes into contact with the sodium and reference electrodes.

The sample flows past the electrodes and exits the flow cell. The sample then exits through the left-side portion of the drain located at the bottom of the case. (The drain has two exits – one for buffered sample and one for sample overflow.) The potential developed between the sodium measuring (ion-responsive) electrode and reference electrode is logarithmic with respect to changes in sodium ion concentration. The signal from the electrodes is fed to the pre-amplifier, which converts the voltage into current. The output from the pre-amplifier is then sent to the transmitter unit via the interconnection cable.

A temperature sensor (thermistor) is housed in the flow cell and detects the temperature of the sample. The thermistor is connected to the transmitter unit and compensates for changes in output from the electrode pair over a range of 41°F to 131°F (5 °C to 55°C).

Calibration of the analyzer is controlled by the microcontroller. After the user connects the transmitter unit to the wet section, it is necessary to perform a successful two-point calibration. See Section 3.4.3 for more details on calibration. Once a successful calibration is performed, the unit is now ready to measure the sodium concentration in the sample. The display then shows the ppm/ppb concentration of the sample while the analyzer compensates for the variations in the sample temperature automatically.



3.2 ALARMS

Sample Concentration Alarms

When the 9135 Sodium system is in normal operation mode, one alarm operates as a “low” alarm and the other operates as a ‘high’ alarm. Alarm 1 (A1) operates as a LOW alarm and is activated when the sodium level decreases below the set value. Alarm 2 (A2) operates as a HIGH alarm and is activated when the sodium level increases above the set value. The two sodium alarms control the relays provided. Each relay has one pair of changeover contacts rated at 5A, 250VAC.

Various Alarm Descriptions

| ALARM | DESCRIPTION |
|------------------|--|
| CALIBRATION FAIL | Analyzer failed calibration |
| SAMPLE HOT | Sample temperature over range (131F) |
| T. SENSOR FAIL | No thermistor response |
| O/P 1 Out | Concentration is outside the set measurement range for 4-20mA output |
| O/P 2 Out | Temperature is outside the set measurement range for 4-20mA output |
| CONC. LOW | Concentration is below Low Alarm set point |
| CONC. HIGH | Concentration is above High Alarm set point |
| OVR | Concentration is above limits of analyzer (>10ppm) |
| OUT | Sample flowrate to analyzer is not sufficient |

3.3 GETTING STARTED

- o Connect the POWER cord to the AC socket terminal connector located at the Corner plate of the analyzer. After power-up, the analyzer enters into Measurement Mode.
- o The analyzer automatically displays the concentration of sodium interpreted by the electrodes.
- o If the analyzer is being started up for the first time, or if it was not in operation for a long time, the user should perform a 2-point calibration as detailed in Section 3.4.3.

3.4 SOFTWARE PROGRAMMING

The X Module Analyzer has been designed to retain all the same functionality as the superseded Model 9033, but with a much more user-friendly interface. It is equipped with a touch screen HMI that allows more straightforward navigation through the menu options as well as enhanced capabilities. Improvements include increased data log storage space, programming to avoid the high concentration alarm after running calibration, and options to add different languages.

3.4.1 SOFTWARE STRUCTURE MAP

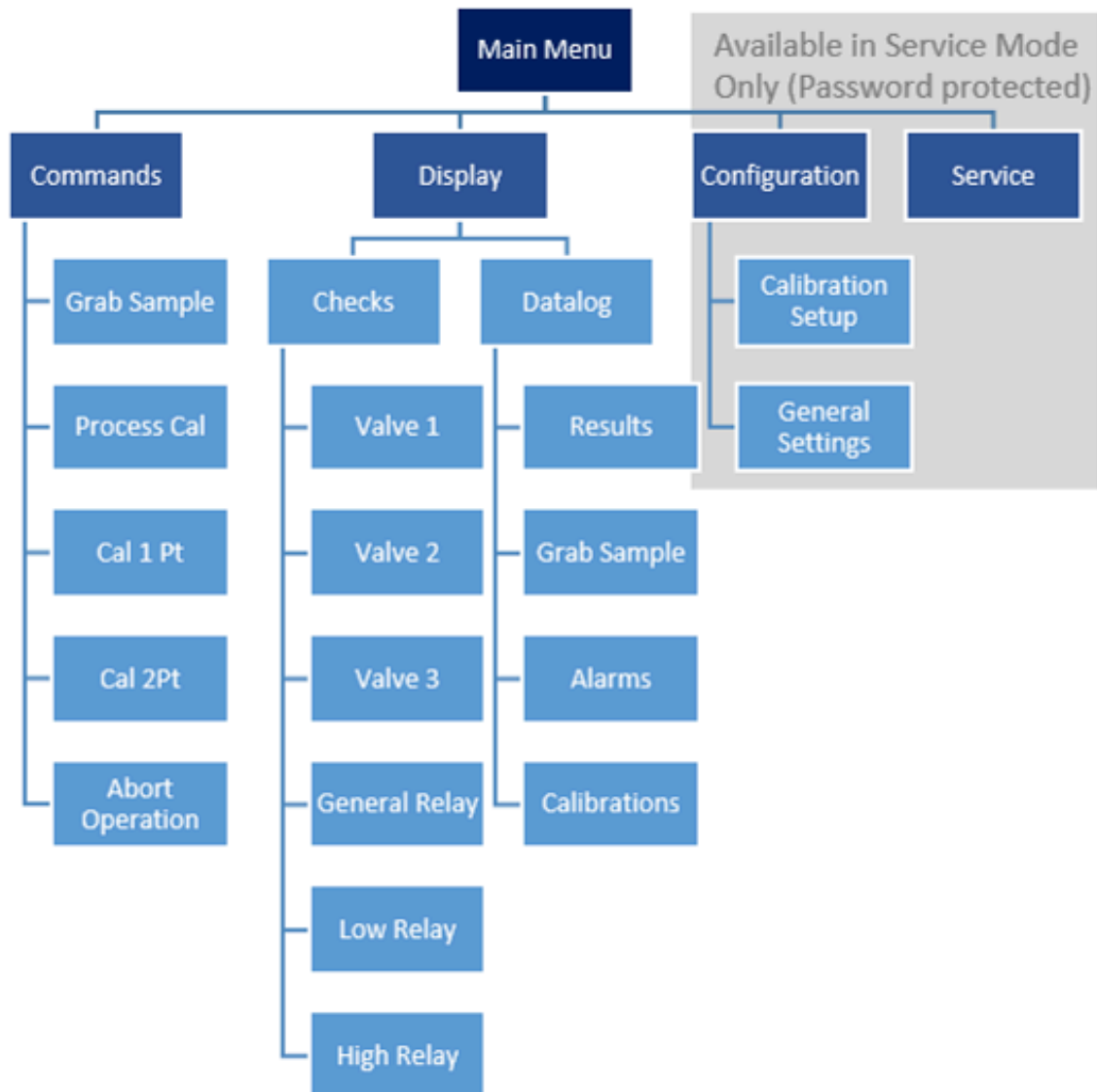

3.4.2 MAIN MENU – USER MODE

The default display when the analyzer is online is the Main Menu in User Mode. In User Mode, the user is able to access only the COMMANDS window and the DISPLAY window and all functions within these windows.

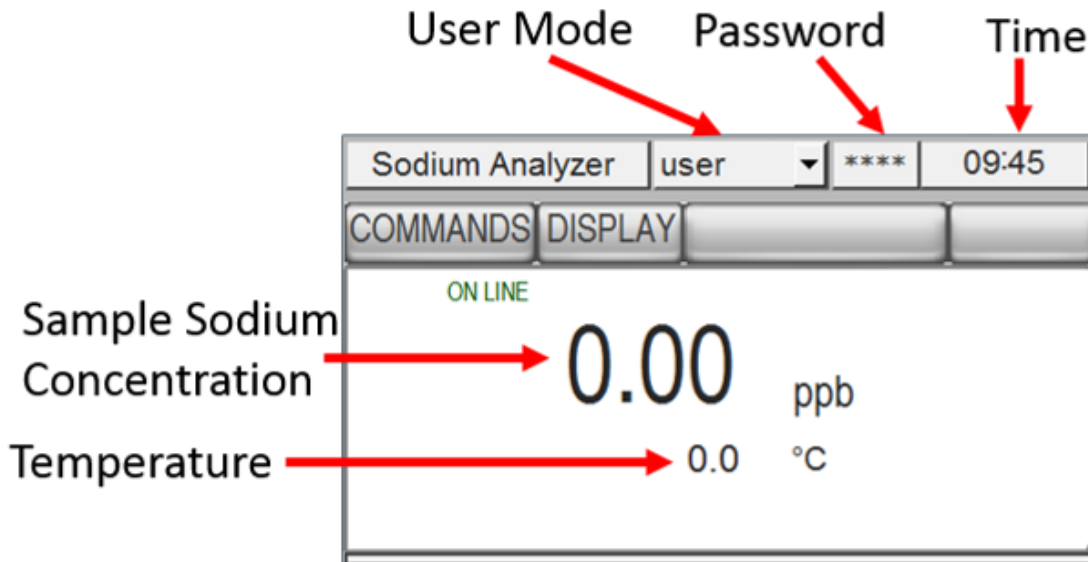

3.4.3 COMMANDS WINDOW

Use the touch screen to open the Commands Window to run grab samples or calibrations.

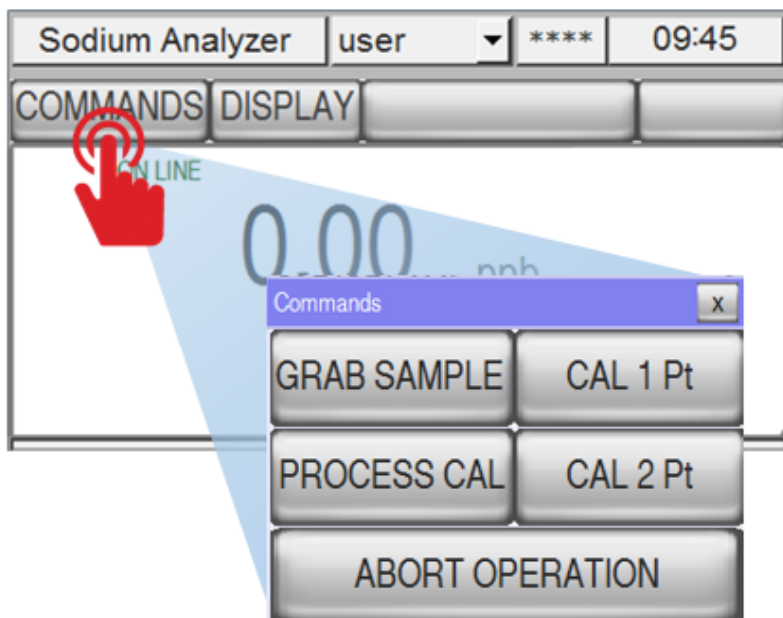

3.4.3.1 GRAB SAMPLE

The GRAB SAMPLE cycle is helpful in that it can be used as a bench test or QA/QC check. The grab sample is used to measure the sodium concentration of any “grab sample” solution.

When GRAB SAMPLE is initiated, solenoid 3 is activated, and the grab sample solution is brought into the system. All the other solenoids are deactivated, and the recorder outputs will continue to hold their last measured value obtained during normal measurement.

To Perform a Grab Sample:

Pour the grab sample solution into the grab sample container before initiating the cycle. Connect the grab sample tubing. Then initiate the GRAB SAMPLE command by pressing the “GRAB SAMPLE” button on the touch screen from the Commands Window. Grab Sample results are stored in the Grab Sample Data Log.

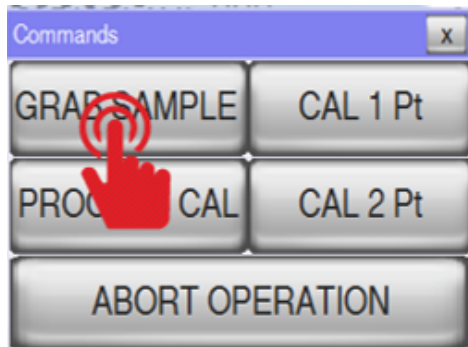

3.4.3.2 CAL 1 Pt

A Single Point (1-Pt) calibration should be performed only if the analyzer has successfully passed a 2-Pt calibration. For 1-Pt calibration, the first solenoid valve is energized, and CAL1 solution flows through the flow cell. During a 1-Pt calibration, the analyzer calibrates by changing the offset of the slope taken during the last 2-Pt calibration.

NOTE: During single point calibration, the sample needs to be delivered to the analyzer at a flow rate of 150-400ml/min. If not, calibration will result in CF.

Description of 1-Pt Calibration Process:

1. After CAL is initiated, solenoid valve #3 (Grab Sample) is opened for 2 minutes to drain any grab sample solution left in the bottle.
2. Solenoid valve #1 (CAL1) is opened for 10 minutes to rinse out the system and update with a 100 ppb solution.
3. Solenoid valve #3 is then activated, and CAL1 flow is restricted for 3 minutes. This allows the sodium electrodes to continue measuring standard without using excess calibration solution.
4. Solenoid valve #1 is then opened again, and CAL1 solution flows through the system for 10 minutes; the final millivolt output for CAL1 (m1) reading is taken and stored into memory.
5. Calibration is complete. Results are shown on the display for 1 minute and then stored in the Calibration Data Log.

To perform 1-Pt Calibration:

- 1) Ensure sample is delivered to analyzer at a flow rate of 150-400ml/min
- 2) Place a low-concentration solution (100ppb) in the container CAL1.
- 4) Check that the high and low solution concentrations need to be entered in the system under CALIBRATION SETUP. Refer to Section 3.4.5.1.1 for more details.
- 5) Ensure the Grab Sample bottle is empty or disconnected.
- 6) Press the “CAL 1 Pt” Button in the Commands Window.

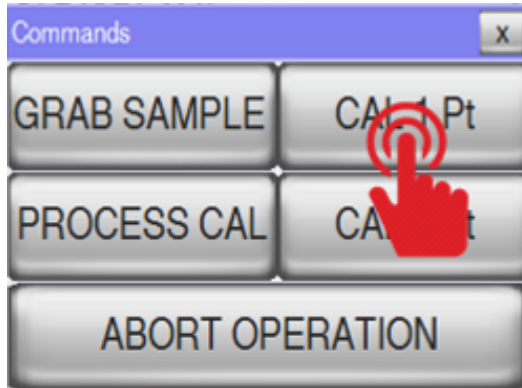

3.4.3.3 Cal 2 Pt

A 2-Point calibration must be performed (and passed) for the instrument to function correctly. Before initiating a calibration sequence, rinse the two standard solution containers with high-purity (DI) water and fill them with fresh sodium standard solutions. This establishes the slope of the calibration curve.

During a 2-Pt calibration, the first solenoid valve is energized first, and CAL1 solution flows through the flow cell. Once the analyzer finishes measuring the CAL1 solution, the first solenoid valve is deactivated and the second solenoid valve is activated, thus allowing CAL2 solution to flow through the flow cell. The analyzer calibrates by measuring the change in mV values between the CAL1 and CAL2 solutions and comparing this “strength” (sometimes called “slope”) to theoretical values. NOTE: During two point calibration sample needs to be delivered to the analyzer at a flow rate of 150-400ml/min. If not, calibration will result in CF.

The frequency of calibrations depends on the operating conditions and electrode conditions. Waltron recommends performing a 2-Point calibration at least once a week to eliminate drift due to changing electrode response.

Description of 2-Pt Calibration Process:

1. After CAL is initiated, solenoid valve #3 (Grab Sample) is opened for 2 minutes to drain any grab sample solution left in the bottle.
2. Solenoid valve #1 (CAL1) is opened for 10 minutes to rinse out the system and update with 100ppb solution.
3. Solenoid valve #1 is then opened again, and CAL1 solution flows through the system for 10 minutes; the final millivolt output for CAL1 (m1) reading is taken and stored into memory.
4. Solenoid valve #2 (CAL2) is opened for 10 minutes to rinse out the system and update with 1ppm solution.
5. Solenoid valve #2 is then opened again, and CAL2 solution flows through the system for 10 minutes; the final millivolt output for CAL2 (m2) reading is taken and stored into memory.
6. Calibration is complete. Results are shown on the display for 1 minute and then stored in CAL LOG.

To Perform 2-Pt Calibration:

- 1) Ensure the sample is delivered to the analyzer at a flow rate of 150-400ml/min
- 2) Place a low-concentration solution (100ppb) in the container CAL1.
- 3) Place a high-concentration solution (1ppm) in the container CAL2.
- 4) Check that the high and low solution concentrations need to be entered in the system under CALIBRATION SETUP. Refer to Section 3.5.4.1.1 for more details.
- 5) Ensure the Grab Sample bottle is empty or disconnected.
- 6) Press the “CAL 2 Pt” Button in the Commands Window.

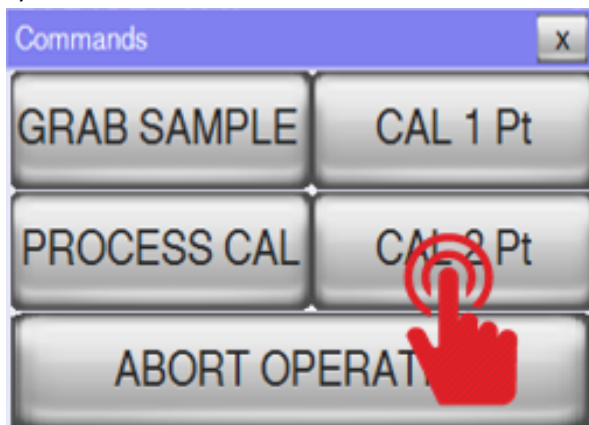

3.4.3.4 PROCESS CALIBRATION

A Process Calibration (PROCESS CAL) can be performed only if the analyzer has successfully passed a 2-Pt calibration. During PROCESS CAL, none of the solenoid valves are energized, and the instrument is calibrated directly to the sample running through the flow cell. The analyzer calibrates by changing the offset of the strength/slope taken during the last 2-Pt calibration.

To perform Process Calibration:

From the Commands Window, press the “PROCESS CAL” button. Press on the “0.0 ppb” to open the numerical keypad.



Enter in the expected concentration of the sample and press “ENT.” You will then see the entered value in the “Process cal. value” window. If you wish to make changes to the entered value, press the number “XX.X ppb” to edit the value and hit “ENT” again. Press “CALIBRATE” when ready. The Process Calibration will begin.

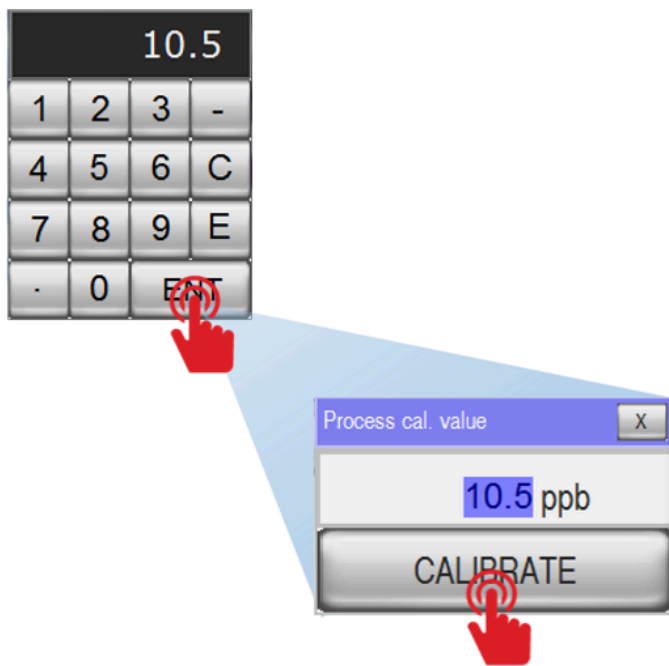

3.4.3.5 ABORT OPERATION

Any calibration cycle or Grab Sample cycle may be interrupted at any time by pressing the ABORT OPERATION button. Once the calibration process is aborted, the measurement screen is displayed.

To abort the operation:

From the Commands window, press the “ABORT OPERATION” button.

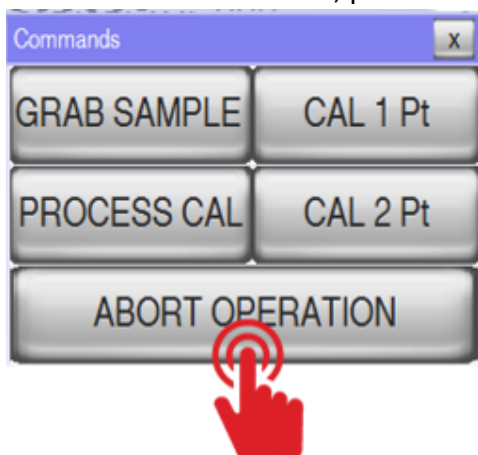

3.4.4 DISPLAY WINDOW

The display window will give you access to useful tools for troubleshooting. The display window will show you the current analyzer reading graphically in mV as well as other useful information. The analyzer can graph in real time the last 10 minutes of the sensor reading in mV. Each vertical line represents two minutes. The Y-axis represents the sensor output in mV.

To access the Display Window:

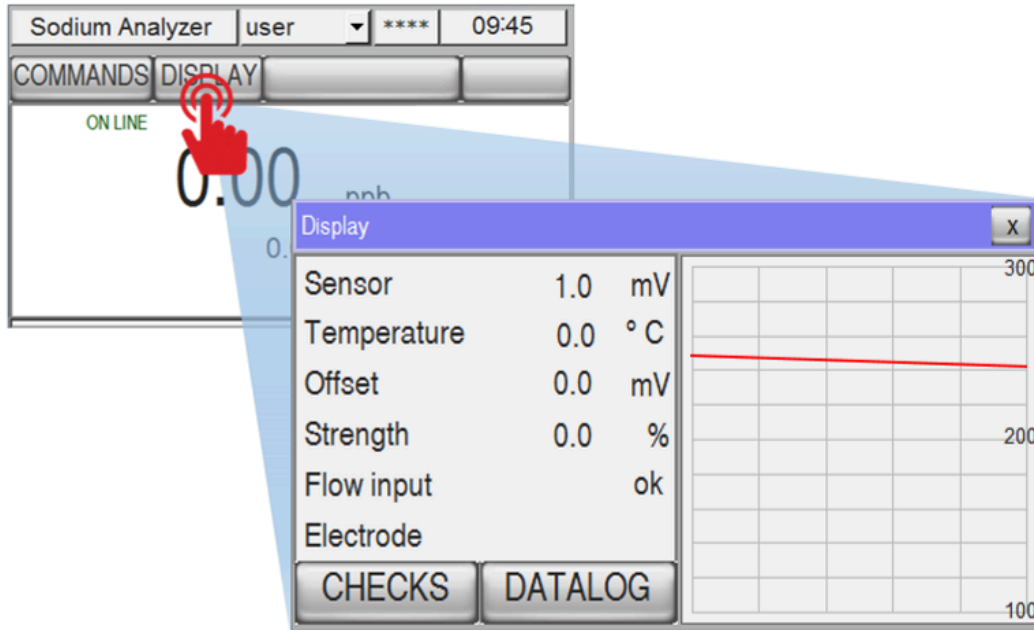

Sensor: Potential reading

Temperature: Temperature reading of the sample at the flow cell

Offset: Offset from the strength of the last calibration

Strength: Percentage of mV1 reading vs mV2 (also referred to as slope)

Flow input: Displays flow switch output (default ok if no flow switch is installed)

Electrode: Displays the user-inputted value for electrode identification (useful for recording the date of electrode replacement, etc)

3.4.4.1 Checks Window

The “CHECKS” function allows you to perform maintenance diagnostics on the three-way solenoid valves, the three alarm relays, and the 4-20mA output.

To access the Checks Window:

From the Main Menu, press the “DISPLAY” button. Then press the “CHECKS” button. The buttons for the valves and the relays will toggle on and off. The text within the button will turn red when the valve/relay is open. To simulate the 4-20mA output, press on the button and then enter a value as a percentage into the white box using the keypad.

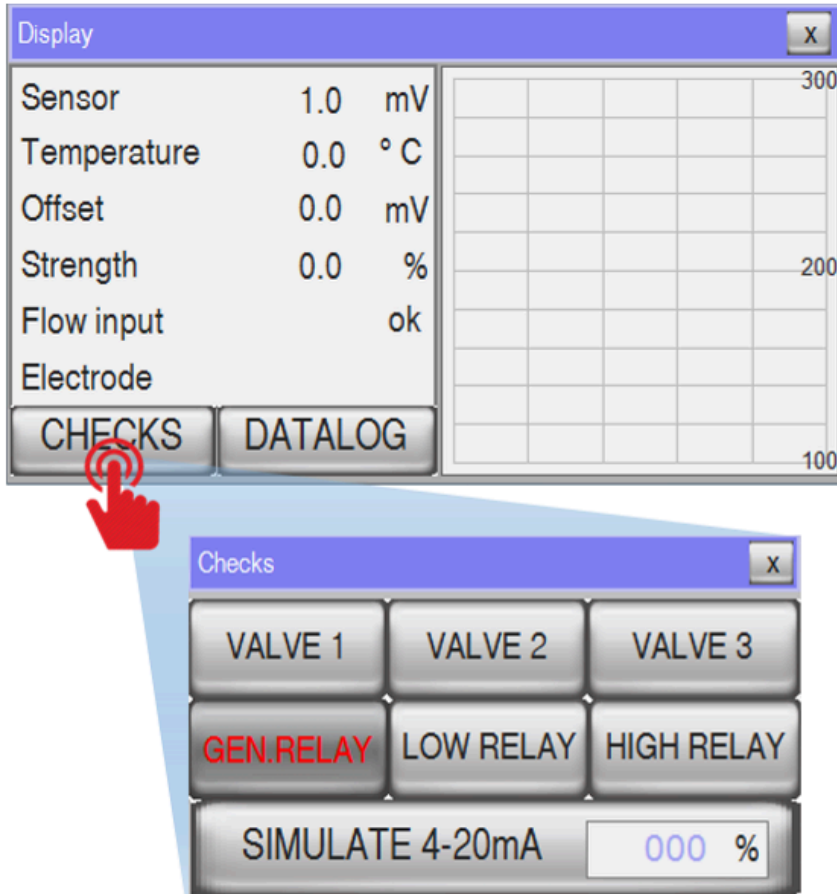

3.4.4.2 Datalog Selection Window

The analyzer is equipped with internal data loggers. Each data logger will automatically record your data and will automatically overwrite the oldest data set and record over with the most recent data set when the log reaches full capacity.

To access the Datalog Selection Window:

From the Main Menu, press the “DISPLAY” button. Then press the “DATALOG” button.

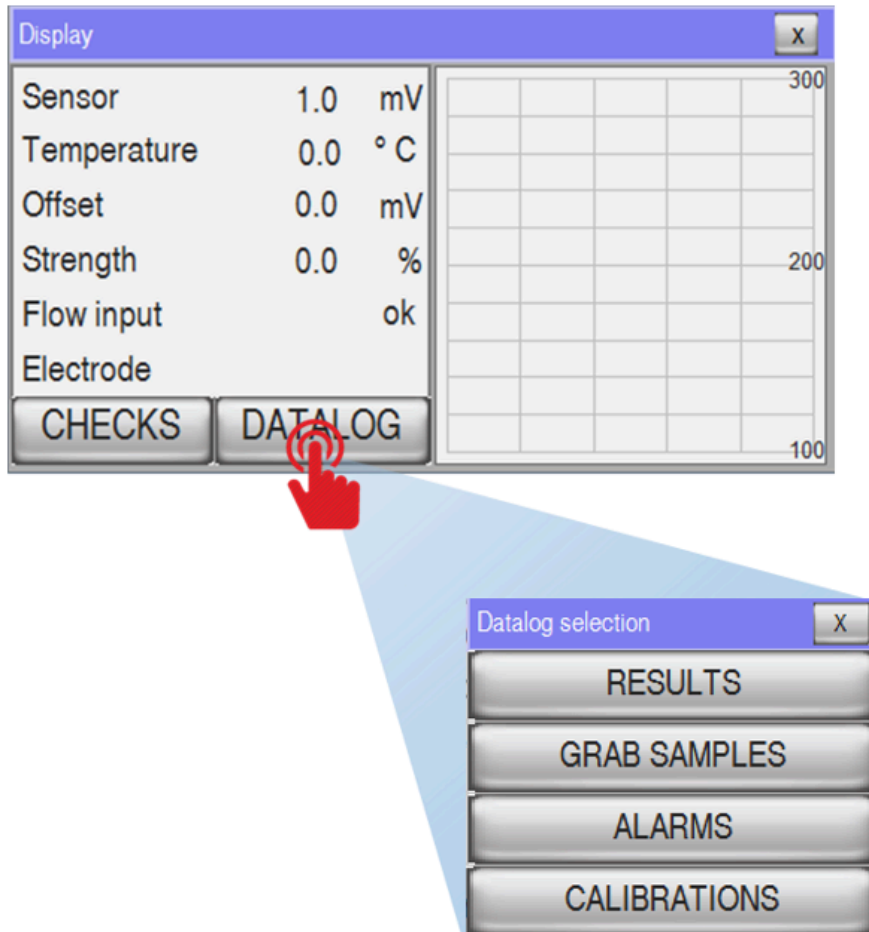

3.4.4.2.1 Results Datalog

Results of your concentration readings by time and date are recorded in the Results Datalog. Data is stored for up to 30 days at a sampling rate of 1 sample every 10 minutes. You may scroll up or down to view results for the current day selected and select which day to view by selecting the day from the drop-down menu box in the upper right corner. Dates are displayed in YY.MM.DD format. Results are recorded to the nearest hundredth of a ppb.

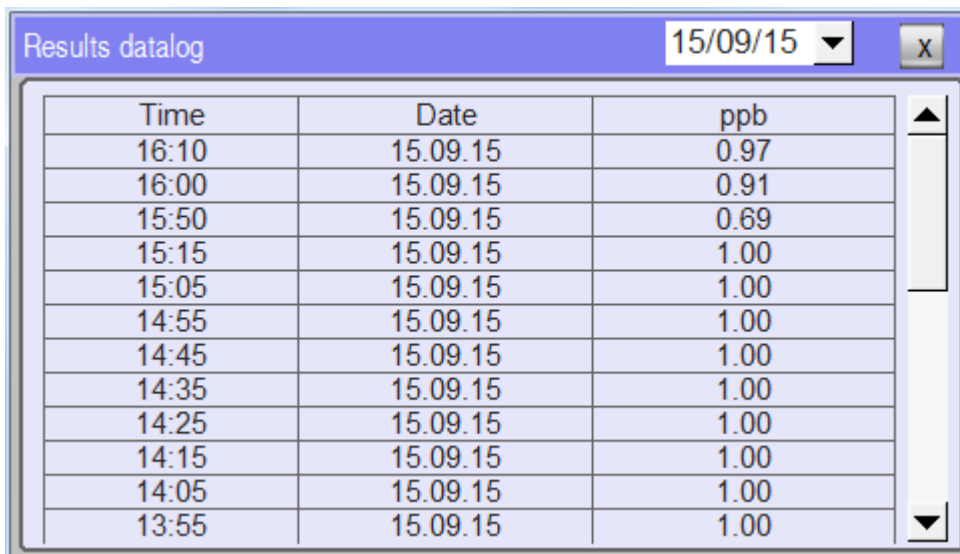

| Time | Date | ppb |
|-------|----------|------|
| 16:10 | 15.09.15 | 0.97 |
| 16:00 | 15.09.15 | 0.91 |
| 15:50 | 15.09.15 | 0.69 |
| 15:15 | 15.09.15 | 1.00 |
| 15:05 | 15.09.15 | 1.00 |
| 14:55 | 15.09.15 | 1.00 |
| 14:45 | 15.09.15 | 1.00 |
| 14:35 | 15.09.15 | 1.00 |
| 14:25 | 15.09.15 | 1.00 |
| 14:15 | 15.09.15 | 1.00 |
| 14:05 | 15.09.15 | 1.00 |
| 13:55 | 15.09.15 | 1.00 |

3.4.4.2.2 Grab Sample Datalog

Results of your grab samples are saved within the Grab samples Datalog. The Datalog will show the results of the last 10 grab samples rounded off to the nearest whole ppb.

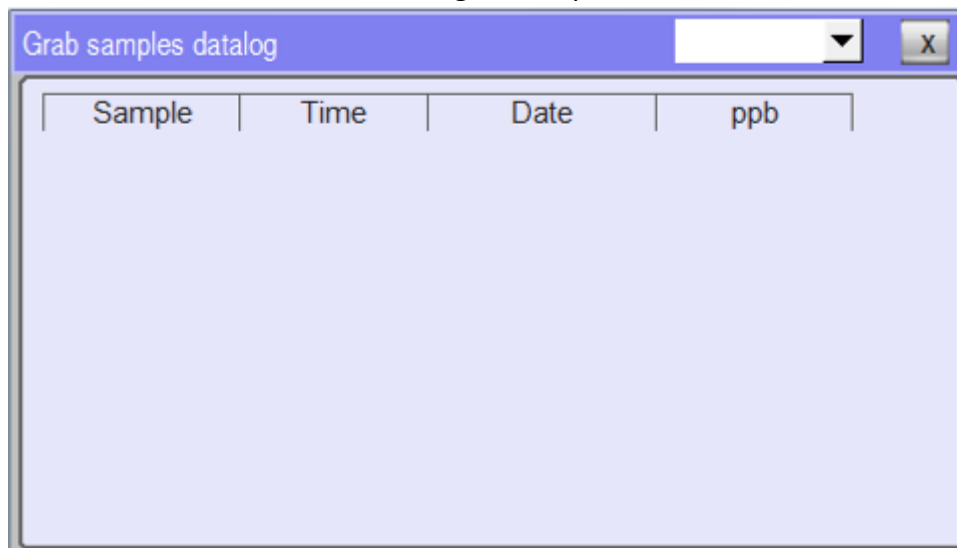

| Sample | Time | Date | ppb |
|--------|------|------|-----|
| | | | |
| | | | |
| | | | |
| | | | |
| | | | |
| | | | |
| | | | |
| | | | |
| | | | |
| | | | |

3.4.4.2.3 Alarms Datalog

The last 10 alarms are saved under the Alarms Datalog with red text. The user may press on the red text to turn it green to indicate the alarm has been addressed. A description of all the alarms is given in Section 3.2

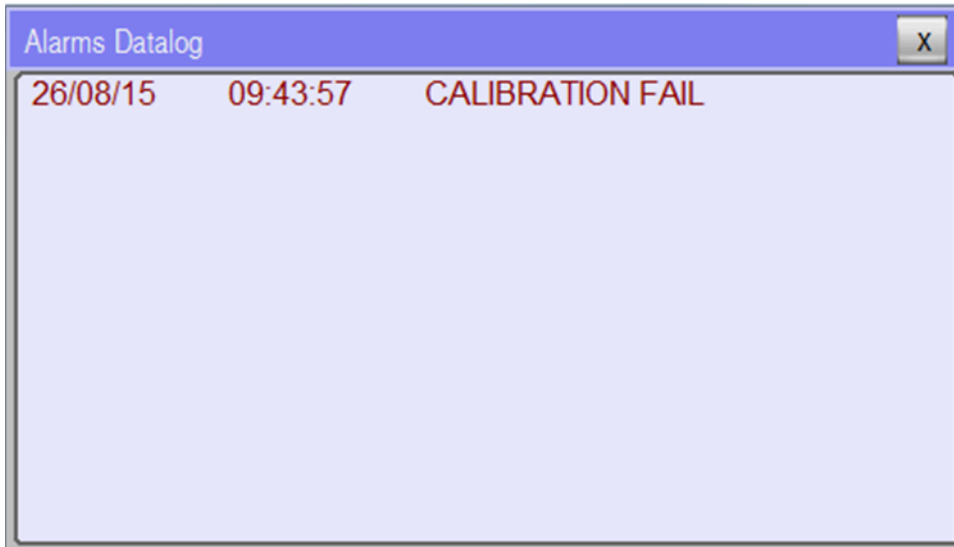

The screenshot shows a window titled "Alarms Datalog" with a close button (X) in the top right corner. The main area contains a single line of text: "26/08/15 09:43:57 CALIBRATION FAIL".

| Time | Date | Message |
|----------|----------|------------------|
| 26/08/15 | 09:43:57 | CALIBRATION FAIL |

3.4.4.2.4 Calibrations Datalog

Results of the last 10 calibrations are stored in the Calibration Datalog. Each result is recorded with the Time and Date the calibration occurred, Strength (or slope), Outcome (pass or fail), and mV1 and mV2 (the readings in mV of the low and high calibration standards).

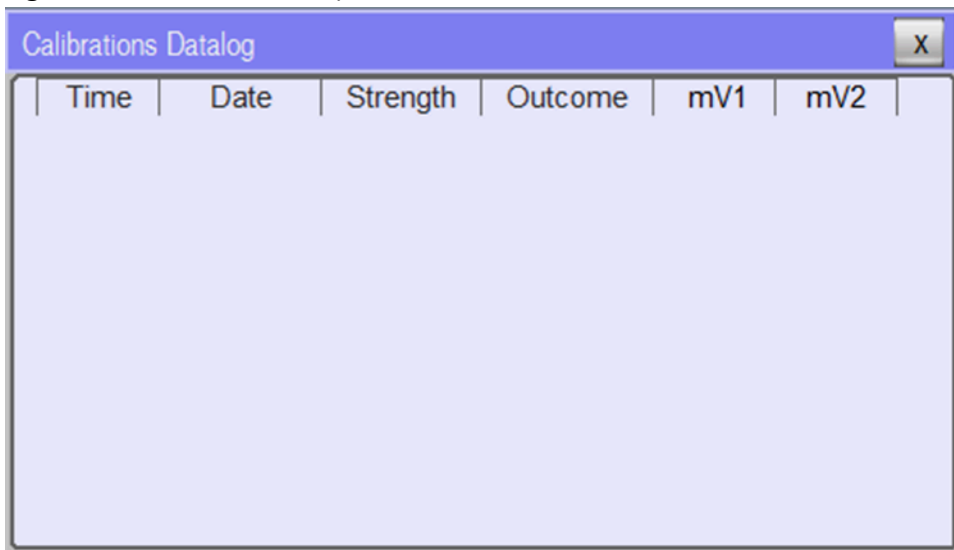

The screenshot shows a window titled "Calibrations Datalog" with a close button (X) in the top right corner. The main area contains a table with the following headers: Time, Date, Strength, Outcome, mV1, and mV2.

| Time | Date | Strength | Outcome | mV1 | mV2 |
|------|------|----------|---------|-----|-----|
|------|------|----------|---------|-----|-----|

3.4.5 MAIN MENU – SERVICE MODE

The analyzer will default to operating in User Mode, where the user can only access the functions in the "COMMANDS" window and the "DISPLAY" window (see Section 3.4.1). More features are available for the advanced user within the Service Mode, which is password-protected.

To access Service Mode:

From the Main Menu, select “service” from the drop-down menu at the top of the screen.

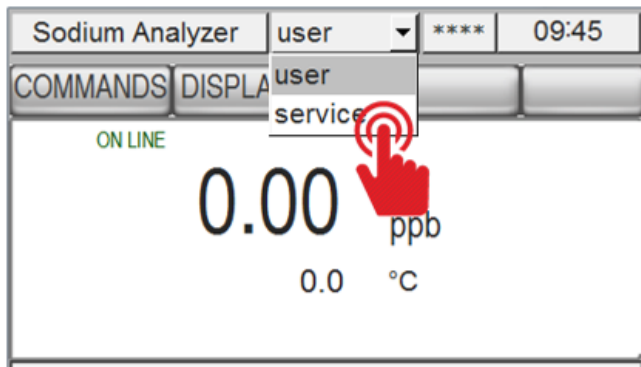

After service has been selected, press the “****” to open the keypad. Enter “6699” on the keypad and press “ENT.” After the correct password is entered, the “CONFIGURATION” and “SERVICE” buttons will become available.

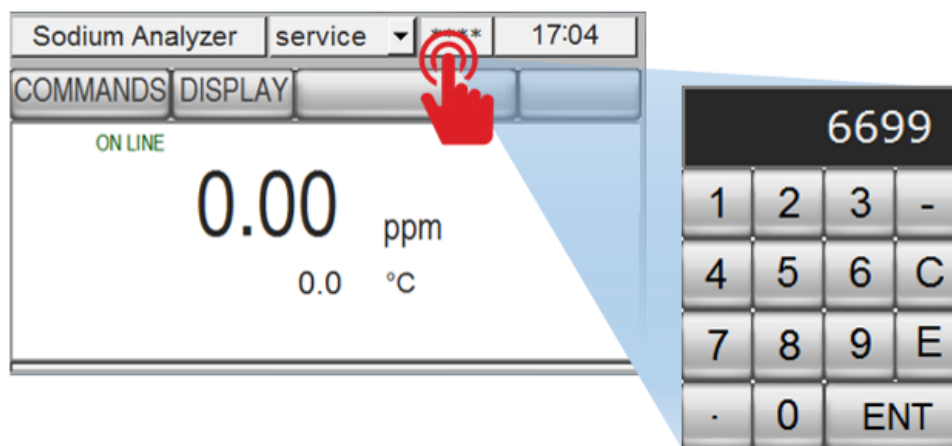

3.4.5.1 Configuration Window – Service Mode

The Configuration Window will give you access to calibration setup and general settings.

To access the Configuration Window:

From the Main Menu under service mode, press the “CONFIGURATION” button.

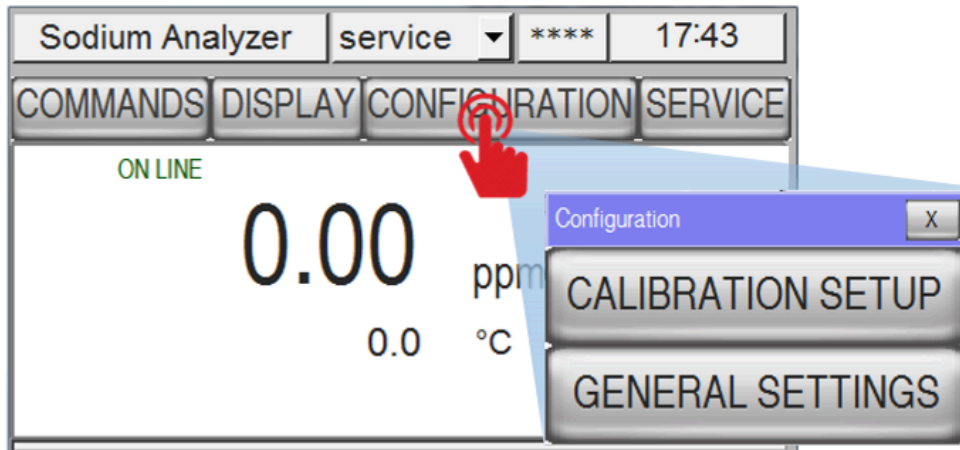

3.4.5.1.1 Calibration Set Up Menu

The Calibration Set Up menu will allow you to make adjustments to automatic calibration settings. You may choose the frequency of automatic calibration, as well as the date and time that the calibration will occur.

Calibration time: enter the time of the day that you wish the calibration to start in 24-hour format

Sun Mon Tue ... Toggle on or off the day of the week you wish the calibration to occur

Week frequency: enter how many weeks you would like to elapse between each calibration (0, 1, 2, 3, or 4). For example, Week frequency = 2 will set calibration for every other week, or Week frequency = 4 will set calibration for every 4 weeks. If you wish to turn automatic calibration off, set Week frequency = 0. Waltron recommends week frequency = 1 for optimal performance of your analyzer.

Now week: this is a counter reflecting which week number the analyzer is on within the set Week frequency. For example, if the Week frequency = 2 and Now week = 1, then the calibration will be set to go off the following week.

Standard sol.1: This should represent the concentration of the low sodium standard and should be set to 100 ppb

Standard sol.2: This should represent the concentration of the high sodium standard and should be set to 1000ppb

Calibration mode: Toggle between dual calibration (two-point) and single calibration (single point). Waltron recommends dual calibration for optimal accuracy.

To access the Calibration setup menu:

From the Main Menu under service mode, press the “CONFIGURATION” button. Then press the “CALIBRATION SET UP” button.

| Calibration set up | | X |
|--------------------|------------------|------------|
| Calibration time | 00:00 | |
| Sun | Mon | Tue |
| Wed | Thu | Fri |
| Sat | | |
| Week frequency | 2 | Now week 0 |
| Standard sol.1 | 100 | ppb |
| Standard sol.2 | 1000 | ppb |
| Calibration mode | Dual calibration | |

3.4.5.1.2 General Settings Menu

The General Settings Menu will allow the user to set alarm ranges, time, and date.

Low conc.alarm: set the alarm limit for a low concentration of sodium sample

High conc.alarm: set the alarm limit for a high concentration of sodium sample

Measure range: set the measurement range

Temp.range: enter the upper limit of your temperature range

Time & date: enter the time and date for the analyzer’s internal clock

To access the General settings menu:

From the Main Menu under service mode, press the “CONFIGURATION” button. Then press the “GENERAL SETTINGS” button.

| General settings | | X |
|------------------|-------|------------|
| Low conc.alarm | 0.0 | ppb |
| High conc.alarm | 100.0 | ppb |
| Measure range | 1000 | ppb |
| Temp. range | 60 | °C |
| Time & date | 09:54 | 26/08/2015 |

3.4.6 SERVICE MENU

The service menu allows you to adjust some of the programming of the analyzer. The software version number is indicated in the menu bar at the top of the window.



Conc. unit: toggle between ppb or ppm

T.unit: toggle between °C and °F for the display temperature of the thermistor

4mA adj: adjust for the 4-20mA output

20mA adj: adjust for the 4-20mA output

Electrode

Zero mV adj: adjust for the mV reading at 4 mA

Span mV adj: adjust for the mV reading at 20mA

T.corr.: adjust for thermistor error (up to +/- 3 °C or °F)

RS485 2W Modbus param.

Slave ID: adjust for Slave identification number

BaudRate = 9600

DataBits = 8

Parity = Even

StopBit = 1

Valves Timing (min)

Variables in this block set the timing for the calibration sequences.

Drain GS period: Drain the grab sample

Init period: Allows the sensors to adjust to the calibration fluid

Restrict time: Waltron recommends this set to 0

Stable time: Allows the sensors to adjust to the calibration fluid

Cond. Time: Holds the analyzer output value at the last sensor value before initiating calibration to allow the sensors to adjust back down to normal operating levels after running calibration standard through the flow cell.

mV Cal 1: displays the mV reading of calibration standard 1 from the last calibration

mV Cal 2: displays the mV reading of calibration standard 2 from the last calibration

Average factor: increasing the average factor will increase noise dampening and decrease the response time of the analyzer. Waltron recommends Average factor = 30

Sensor data: this is a free text field up to 12 characters. The user may input the date of exchange of a new sensor, the name of a sensor, etc.

Backlight Off delay: user may adjust the time the analyzer takes to turn off the backlight on the display in order to save the life of the HMI screen / save energy. This may be from 0 min to 120 mins.

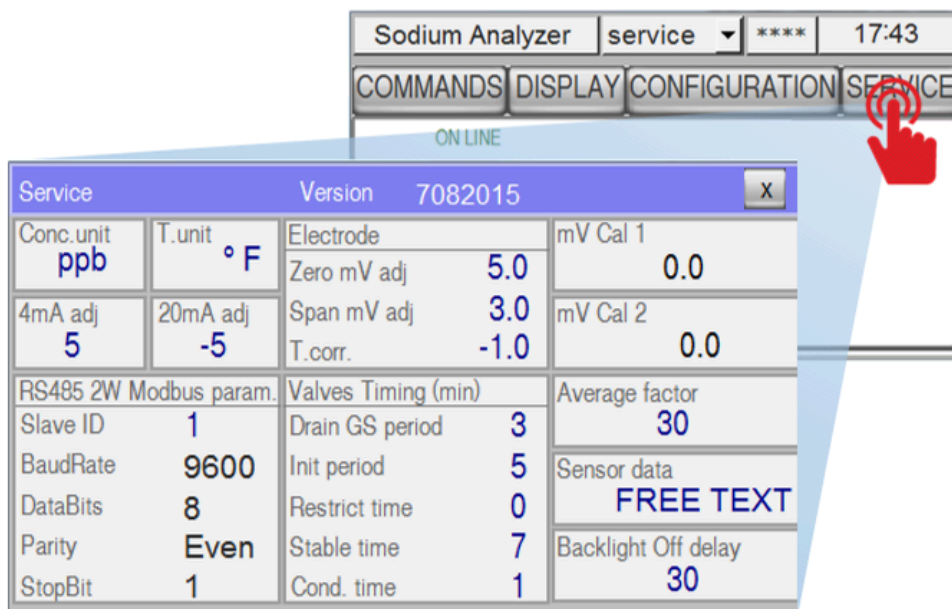

3.4.7 AUTO CALIBRATION

The analyzer can be set up to perform an automatic 1-Pt or 2-Pt calibration during a user-defined period.

3.4.8 CALIBRATION FAILURE

A Calibration Fail (CAL FAIL) condition will occur after a 2-Pt calibration if the electrode response does not meet requirements. This happens when the electrodes' "strength" ("slope") from a 2-Pt calibration is below 83 or greater than 110. This could be caused by a number of factors (See next section - Troubleshooting).

NOTE: During single and two point calibrations sample needs to be delivered to the analyzer at a flow rate of 150-400ml/min. If not, calibration will result in CF.

4 TROUBLESHOOTING – CALIBRATION FAIL

STRENGTH LESS THAN 83%

- Make sure standard containers (CAL1 and CAL2) are full of solution.
- Check that vapor bubbles are emerging from the bottom of the stainless steel entrainment tube.
- Check the condition of the reagent solution.
- Regenerate the sodium measuring electrode. See Section 5.5.2
- If the slope value is not improved after the sodium measuring electrode is regenerated, the electrode may need to be replaced.

STRENGTH MORE THAN 100%

- The possible cause may be a faulty reference electrode. Check the status of the reference
Electrode filling solution and add more if using N3010-174.
- Check the status of the reference electrode and replace if necessary.
- Make sure standard containers (CAL1 and CAL2) are full of solution.

VERY LOW OR 0% SLOPE

- Check the operation of the solenoid valve(s).
- Check the flow of the standard solution through the flow cell.
- Check the level of the salt bridge solution in the reference electrode, if using N3010-174.
- Check for an open-circuit reference electrode by substituting it with an electrode of known performance.
- Make sure standard containers (CAL1 and CAL2) are full of solution.
- Make sure the low 100ppb standard is connected to Cal1 tubing and high 1000ppb standard is connected to Cal2 tubing. Note that the high standard is red in color.



5 MAINTENANCE

5.1 BUFFER SOLUTION(S)

- **WARNING!** These buffers are mildly hazardous and should be handled according to the SDS

Two alternative reagent solutions may be used, depending on the required lower limit of measurement. Concentrated ammonia solution, which provides adjustment of sample pH to 10.7, is suitable for measurements of sodium ion to approximately 0.5ppb. At concentrations below 0.5ppb, hydrogen ion interference becomes significant, and a reagent of Diisopropylamine solution should be used. This adjusts the sample pH to 11.2 - 11.5 and enables measurements to be made to concentrations below 0.5ppb.

Concentrated Ammonia Solution - 1 liter

- **WARNING!** This buffer should only be handled under a fume hood. It causes burns and is irritating to the eyes, respiratory system, and skin. Wear rubber gloves and eye protection. In warm weather, pressure increases in the bulk container of ammonia, and the cap must be released with care.

Note. Waltron offers Ammonium Hydroxide in a 2.5-liter container. Part Number N1234-116.

Diisopropylamine Solution

- **WARNING!** Diisopropylamine is an extremely inflammable and irritating colorless liquid with a strong smell of ammonia. It should be handled with care at all times. The following points should also be noted:
- Avoid breathing vapor and avoid contact with skin and eyes.
- Work under a fume hood, wearing rubber gloves and eye protection.
- In the event of a fire, extinguish with water spray, foam, dry powder or carbon dioxide.
- If a spill occurs, shut off all possible sources of ignition and instruct others to keep at a safe distance. Mop up the spill with plenty of water, diluting greatly. Ventilate the area well to evaporate any remaining liquid and dispel vapor.
- Effluent from the analyzer contains diisopropylamine (if this buffer is used). Contact with it should also be avoided.

5.2 STANDARD SOLUTIONS

- ✓ Waltron offers Sodium Standard, 100 ppb, in a 1-gallon container. Part Number N1234-540.
- ✓ Waltron also offers Sodium Standard, 1 ppm, in a 1-gallon container. Part Number N1234-541. Note that the high calibration standard is red in color to avoid confusion when installing calibration standards.

- o Do not use static sodium solutions of less than 50ppb because low concentration solutions rapidly become contaminated and change in concentration.
- o Although the HIGH and LOW standard solutions are typically one decade apart in sodium concentration, any concentration difference can be used within the constraints of i) above and the need to have a significant change in electrode output to achieve an accurate calibration.

Note. High-purity water is water containing less than 2ppb sodium ions and a specific conductivity of less than approximately 0.2 μ S/cm.

5.3 ETCHING SOLUTION

Note. Waltron offers the solution under our Part Number N1234-543, Sodium Electrode Regeneration Solution, 2 oz. size.

For use on applications where the sample sodium concentration is below 1ppb - see also Section 5.5.2.

- **WARNING!** Sodium Fluoride is toxic. Avoid inhaling the dust and prevent contact with skin and eyes. Wear a dust mask, rubber gloves, and eye protection. When prepared, the etching solution contains 0.1 M hydrofluoric acid (0.2% HF). Take care to prevent contact with skin and eyes.

5.4 REFERENCE ELECTRODE FILL SOLUTION (For Use with N3010-174)

Waltron offers a stock solution of 3.5 KCL Ref. Electrode Filling Solution in a 2 oz. size. Part Number N1234-548.



This solution is required for refilling the calomel reference electrode. This solution should be stored in a tightly sealed plastic bottle. The electrode is conveniently filled using the automatic KCl refill system.

5.5 SCHEDULED SERVICING

The following procedures are guides to the maintenance requirements of the monitor. The procedure chosen depends on the particular installation and sample conditions.

5.5.1 WEEKLY

If the monitor is continuously running at high concentrations, greater than 100ppb, a weekly Single Point Calibration is recommended. See Section 3.4.3.2 Single Point Calibration.

5.5.2 MONTHLY

- o Replace the bottle of reagent buffer solution. If using ammonia, the level of the solution should not be allowed to fall below about three-quarters full. If using DIPA, the level of the solution will be near empty. On high ambient temperature installations and for low sodium concentrations, the solution may require replacement more frequently.
- o Check the level of the reference electrode filling solution bottle; replace as required.
- o The following procedures should be carried out:

When the sodium concentration is above 1ppb, carry out a Two-Point Calibration - see Section 3.4.3.3; note the slope value.

Sodium Measuring Electrode Etching/Regeneration Instructions:

When the sodium concentration is below 1ppb, apply the following regen/etch procedure before carrying out a Two-Point Calibration:

Note. When used for prolonged periods at low concentrations, the leeching of sodium ions from the electrode surface accelerates the aging process of the electrode, which is shown by poor response time, low slope value, and a limitation in responding to low levels. Calibration may then be in error because of slow response and poor reproducibility. The regen procedure minimizes problems from these sources.

Also: Etching is not for new probes- this should be done as part of the monthly maintenance procedure.

- o Remove the sodium electrode from the flow cell; it is not necessary to detach the electrode lead.
- o Prepare two plastic beakers, one containing about 50ml of etching solution, the other about 200ml high purity water.
- o Dip the electrode in the etching solution for 60 (± 5) seconds; then rinse in high-purity water.

 **Caution.** It is important not to exceed the etching time, or the performance of the electrode may be permanently degraded.

- o Dispose of the etching solution by diluting it with plenty of water. Use fresh etching solution each time.

Return the electrode to the flow cell. Prior to performing a calibration, run the monitor for one to two hours on a low-level sodium sample. No further calibration should be needed until the next regen procedure.

This procedure must be carried out at regular monthly intervals, and the process should start as soon as a new electrode is put into service.

Note. It is extremely difficult to recover an 'old' electrode.

As the buffer solution is replaced monthly, the following procedure should be carried out 24 hours after replenishment to allow pH stability to be achieved.

This procedure applies to both ammonia and amine-buffered systems.



5.6 SHUT-DOWN PROCEDURE - (Prolonged Shut-Down, 1+ months)

- o Close the sample valve upstream of the monitor.
- o Remove the buffer container and safely dispose of the solution. Rinse the containers thoroughly.
 - **WARNING!** For safe handling instructions of buffer solutions, refer to Section 5.1.
- o Fill the CAL1 calibration solution container with high-purity water and do a single-point calibration to flush the system.
- o Remove the electrodes and follow the procedure in Section 5.6.1.
- o Use a syringe to flush all tubing with high-purity water. This removes any particulate deposits.
- o Switch off the main power supply to the Transmitter Unit.

5.6.1 STORAGE OF ELECTRODES

Fill the storage bottle, supplied with the **sodium electrode**, with 5M sodium solution. Push the bottle over the end of the electrode and tighten the cap. For the refillable reference electrodes, fill the storage bottle with the refillable solution, push the bottle over the end of the electrode, and tighten. Refit the filling-hole cap to seal the refill aperture. For storing the Gel-filled electrode, fill the rubber teat with a dilute KCl solution and push the teat over the end of the electrode.

Note. Do not let either electrode dry out!!!

5.7 pH EFFECTS

Measuring the pH of the effluent from the flow cell indicates adequate buffering. The minimum pH depends on the minimum sodium concentration, but the pH value is calculated as:

pH must be greater than $pNa + 3$, so ideally at:

- o 100ppb Na+, the pH must be greater than 8.4
- o 10ppb Na+, the pH must be greater than 9.4
- o 1ppb Na+, the pH must be greater than 10.4
- o 0.5ppb Na+, the pH must be greater than 11.4

Note. If the buffer is allowed to become completely exhausted, the reading may be very erratic due to the lack of ionic strength adjustment of the high-purity sample.



6 SPARE PARTS

Consumable Parts

| PART NUMBER | DESCRIPTION |
|-------------|--|
| N1234-540 | Sodium Standard, 100ppb, 1 Gallon Cube, 9135 |
| N1234-541 | Sodium Standard, 1000ppb (1 ppm), Red, 1 Gallon Cube, 9135 |
| N1234-548 | 3.5 M KCl Reference Solution Kit, 9135 |
| N1234-116 | 29% Ammonium Hydroxide (2.5 L) |
| N1234-579 | 99% Di-Isopropylamine (1 Gallon) |
| N1234-543 | Sodium Electrode Regeneration Solution (2 fl.oz.) |
| P2000-050 | Kit, Re-tubing & O-Ring |

Recommended Spare Parts

| PART NUMBER | DESCRIPTION |
|-------------|---|
| N3010-177 | Measuring Electrode |
| N3010-174 | Refillable Reference Electrode |
| N3010-173 | Gel-filled Reference Electrode |
| E2000-007 | BNC Detachable Sodium Probe Cables |
| N3500-326 | Sodium Spare Parts Kit, 6200 Series Valve |
| P1000-067 | Calibration Standard Bladder Cap |

Additional Spare Parts

| PART NUMBER | DESCRIPTION |
|-------------|--|
| N1234-544 | Sodium Standard, 100 ppb (5 gal.) |
| N1234-545 | Sodium Standard, 1000 ppb, Red, (5 gal.) - (1 ppm) |
| P2000-039A | Flowcell Assembly, 9135 |
| N3010-170C | Thermistor |
| N1053-106A | Earthing Tube |
| P2000-100 | Sodium ECM Assembly |
| P2000-054 | Solenoid Cable Assembly |
| N2554-066A | Entrainment "T" Assembly |
| N1142-116B | Buffer Bottle, Square |
| N1142-117B | Vented Cap, Buffer Bottle |
| P2000-053 | Solenoid Valve Assembly |
| P2000-054 | Solenoid Cable Assembly |
| N1138-622 | Fitting 1/8" NPT x 3/16 Tube Elbow |
| N1138-620 | Fitting 1/8" NPT x 3/16" Straight |



| | |
|------------|---|
| P1000-188 | Barbed Tube Fitting, Elbow, 1/16" Tube x 1/8 NPT Male |
| P1000-066 | Grab Sample Bottle |
| P1000-076 | Connector for Grab Sample Bottle |
| P1000-121 | Cable Gland Fitting, Flowcell 9135 |
| P2000-041 | Reagent Buffer Bottle, 9135, DIPA |
| P1000-001A | Solenoid valve bracket |
| P2000-098 | Heat Exchanger Assy, 9135 |
| P2000-002 | Vessel Assy, Constant Head, 9135 |



7 TROUBLE-SHOOTING

| Troubleshooting 9135 | | |
|----------------------|--|--|
| Problem | Possible Cause(s) | Solution(s) |
| Calibration Fail | Empty or Contaminated Standards Solutions Container(s) | Check to make sure calibration standard bottles are full, check calibration tubing to make sure it is not pinched. Replace calibration standard with fresh solution and try again. |
| Calibration Fail | Faulty Solenoid Valve(s) | Run Solenoid Check cycle in Diagnostics – check status and connections of solenoid valves. |
| Calibration Fail | Strength is too low. <83 | Make sure both containers of standard are full of solution. |
| Calibration Fail | Strength is too low. <83 | Verify condition of reagent solution. Replace monthly. |
| Calibration Fail | Strength is too low. <83 | Verify electrodes are connected properly |
| Calibration Fail | Strength is too low. <83 | Check that vapor bubbles are emerging from bottom of entrainment tube. |
| Calibration Fail | Strength is too low. <83 | Ensure reference electrode tip is 42-48 mm from the top of the flowcell (5mm into sample) |
| Calibration Fail | Strength is too low. <83 | Ensure calibration standard is flowing. Perform Solenoid Check cycle in Diagnostics to verify. |
| Calibration Fail | Strength is too low. <83 | Regenerate the sodium measuring electrode. See section 5.5.2 in manual. |
| Calibration Fail | Strength is too high. >110 | Make sure both containers of standard are full of solution. |
| Calibration Fail | Strength is too high. >110 | Check level of reference electrode salt bridge solution; add more if necessary |



| | | |
|---------------------------------------|--|---|
| Calibration Fail | Strength is too high. >110 | Faulty reference electrode. Replace with one of known performance. |
| Calibration Fail | Strength is close to zero. | Make sure both containers of standard are full of solution. |
| Calibration Fail | Strength is close to zero. | Ensure there is flow of standard solution through flow cell. |
| Calibration Fail | Strength is close to zero. | Verify operation of solenoid valves. |
| Calibration Fail | Strength is close to zero. | Check level of salt bridge solution in reference electrode. |
| Calibration Fail | Strength is close to zero. | Faulty reference electrode. Replace with one of known performance. |
| Calibration Fail | No standard flow. | Check for clogs in system. Check for air trapped in tubing. Gently squeeze standard containers to verify flow during appropriate solenoid test. Filter sample if deposits found in analyzer tubing. |
| Calibration Fail | No standard flow. | Check to make sure sample flow is being delivered to analyzer at flow rate 150-400ml/min. |
| Readings are not accurate – too low. | Old/bad reagent. Poor electrode performance. Bad calibration. | Replace reagent solution. Regenerate/replace sodium measuring electrode, refill/replace reference electrode. Check Calibration log and run another calibration if results are not good. |
| Readings are not accurate – too high. | Poor electrode performance. Bad calibration. Sodium leak in sample system. | Regenerate/replace sodium measuring electrode, refill/replace reference electrode. Check calibration log and run another calibration if last result is not good. |



| | | |
|---|---|--|
| Readings are not accurate – erratic | Exhausted reagent | Replace reagent. Recommended monthly |
| Current outputs (4-20mA) not functioning correctly. | Disconnected wiring at transmitter or along wire path. DCS/recording system not set up properly. Bad CPU board. | Check output set-up to make sure values are entered properly. Run Diagnostics – O/Pma Check cycle and check output coming directly from transmitter. Replace CPU board if output is not correct. |
| Alarms not functioning correctly. | Disconnected wiring at transmitter or along wire path. DCS/recording system not set up properly. Bad DIO board. | Check alarm set-up to make sure values are entered properly. Run Diagnostics – Relay Check cycle and check alarm output directly from transmitter. Replace DIO board if output is not correct. |
| Display read “HOT” | Sample temperature over specified range (>131F). Faulty thermistor. | Check sample temperature. Clean/replace thermistor. |
| Display read “TEMP” | No thermistor response. | Clean/replace thermistor. Check thermistor connection at pre-amp. |
| Display read “OVR” | Signal from electrodes too high – sample concentration over maximum range (>10ppm) | Check sample concentration. Check electrode connections at pre-amp. |



8 SPECIFICATIONS

| | |
|------------------------|--|
| Range: | 0.1ppb – 10ppm |
| Accuracy: | +/-5% of reading or +/- 0.1ppb (whichever is greater) within +/-5C of calibration temperature |
| Reproducibility: | +/-5% of reading or +/- 0.1ppb (whichever is greater) at constant temperature |
| Response Time: | 90% of 1-10ppb step: less than 4 minutes; 90% of 100-1ppm step: less than 6 minutes |
| Current Outputs: | Two isolated 4-20mA current (analog) outputs |
| Alarms: | Three voltage-free contacts, alarm points set from transmitter rated at 2A, 250VAC (non-inductive) |
| Power: | Wide range of input power supply 90VAC – 250VAC |
| Sample: | Temperature: 41-131F (5-55C); Flow 150-400ml/min |
| Ambient Temp: | 32-131F (0-55C) |
| Pressure: | 5-30psig |
| Composition: | Sample should be filtered to 60 microns, free of film forming compounds |
| Power Consumption: | Less than 20VA |
| Sample Inlet Fitting: | ¼" Swagelok |
| Sample Outlet Fitting: | Barbed fitting for 3/8" ID hose connection |



9 APPENDIX

This appendix is to be used as a reference. The information provided here is theoretical.

| Sodium Concentration | Theoretical Preamp Input with Sensors (mV) |
|----------------------|--|
| 0.01 ppb | -476.63 |
| 0.02 ppb | -458.82 |
| 0.05 ppb | -435.27 |
| 0.1 ppb | -417.47 |
| 0.2 ppb | -399.66 |
| 0.5 ppb | -377.11 |
| 1 ppb | -358.31 |
| 2 ppb | -340.5 |
| 5 ppb | -316.95 |
| 10 ppb | -299.15 |
| 20 ppb | -281.34 |
| 50 ppb | -257.79 |
| 100 ppb | -239.99 |
| 200 ppb | -222.18 |
| 500 ppb | -198.63 |
| 1 ppm | -180.83 |
| 2 ppm | -163.02 |
| 5 ppm | -139.47 |
| 10ppm | -121.67 |

Approximate electrode mV outputs for calibrations using Waltron Electrodes:

| Refillable Reference Electrode | | Gel-Filled Reference Electrode | |
|--------------------------------|--------------|--------------------------------|--------------|
| mV 1 (100 ppb) | mV 2 (1 ppm) | mV 1 (100 ppb) | mV 2 (1 ppm) |
| 240-260 mV | 180-200 mV | 240-260 mV | 180-200 mV |